

# TM 11-2583A

DEPARTMENT OF THE ARMY TECHNICAL MANUAL

---

## **SOUND RECORDER- REPRODUCER SET AN/TNH-2A**

This copy is reprint which includes current  
pages from changes 1-2-4-6-7-8

*DEPARTMENT OF THE ARMY • JANUARY 1956*

**W A R N I N G**  
**DANGEROUS VOLTAGES EXIST IN THIS EQUIPMENT**

Be careful when working on the B+ plate and  
screen circuits and all power supply circuits,  
or on the 115-volt ac line connections.

**DON'T TAKE CHANCES!**

# Changes in force C1, C2, C4, C6, C7, and C8

TM 11-2583A  
C 8

Change }  
No. 8 }

HEADQUARTERS  
DEPARTMENT OF THE ARMY  
Washington, D.C., 5 November 1973

## SOUND RECORDER-REPRODUCER SETS AN/TNH-2A AND AN/TNH-2B

TM 11-2583A, 30 January 1956. is changed as follows:

*Page 1.* Paragraph 1.1 is superseded as follows:

### 1.1. Indexes of Publications

*a. DA Pam 310-4.* Refer to the latest issue of DA Pam 310-4 to determine whether there are new editions, changes, or additional publications pertaining to the equipment.

*b. DA Pam 920-7.* Refer to DA Pam 310-7 to determine whether there are modification work orders (MWO's) pertaining to the equipment. Paragraph 2 is superseded as follows:

### 2. Forms and Records

*a. Reports of Maintenance and Unsatisfactory Equipment.* Maintenance forms, records, and reports which are to be used by maintenance personnel at all maintenance levels are listed in and prescribed by TM 38-750.

*b. Report of Packaging and Handling Deficiencies.* Fill out and forward DD Form 6 (Report of Packaging and Handling Deficiencies) as prescribed in AR 700-58 (Army)/NAVSUP Pub 378 (Navy)/AFR 71-4 (Air Force)/and MCO P4030.29 (Marine Corps).

*c. Discrepancy in Shipment Report (DISREP) (SF 361).* Fill out and forward Discrepancy in Shipment Report (DISREP) (SF 361) as prescribed in AR 55-38 (Army)/NAVSUP Pub 459 (Navy)/AFM 75-34 (Air Force)/and MCO P4610.19 (Marine Corps).

Paragraph 2.1 is added after paragraph 2.

### 2.1. Reporting of Equipment Publication Improvements

The Reporting of errors, omissions, and recommendations for improving this publication by the individual user is encouraged. Reports should be submitted on DA Form 2028 (Recommended Changes to Publications) and forwarded direct to Commander, US Army Electronics Command, ATTN: AMSEL-MA-C, Fort Monmouth, NJ 07703.

*Page 2,* paragraph 5. Change heading to read "Table of Components and Dimensions of Sound Recorder-Reproducer Set AN/TNH-2A." Paragraph 5.1. Change heading to read "Table of Components and Dimensions of Sound Recorder-Reproducer Set AN/TNH-2B."

*Page 3.* Paragraphs 5.2 and 5.3 are added after paragraph 5.1.

**5.2. Items Comprising Operable Sound Recorder-Reproducer Sets  
AN/TNH-2A (FSN 5835-503-1512) and AN/TNH-2B (FSN 5835-543-0079)**

FSN	QTY	Nomenclature, part No., and mfr code	Usable on code
		NOTE The part number is followed by the applicable 5 digit Federal supply code for manufacturers (FSCM) identified in SB 708-42 and used to identify manufacturer, distributor, or Government agency, etc.	
		NOTE In usable on code column, number 1 refers to Recorder Reproducer Set, Sound, AN/TNH-2A; number 2 refers to Recorder Reproducer Set, Sound, AN/TNH-2B.	
5830-537-7755	1	Amplifier, Audio Frequency AM-124WU, 5w power output, 115v, 60 Hz, single ph. 1 channel input, 50,000 ohm impedance, SC-DL-282750, 80063 (Installed in equip)	1,2
5830-537-7756	1	Amplifier Power Supply AM-1251 /TNH-2A; provides amplification and erase signal for motor board assembly, 19 in. lg x 7 in. h x 14 in. w o/a, SC-DL-282772,80063 (Installed in equip)	1
5835-543-0080	1	Amplifier Power Supply AM-1634 /TNH-2B, AF amplifier, 8w output, 600 ohms impedance, Power Supply 1.6 amp 5v, 115v 60 Hz, single ph. 7 in. x 14 x 19 in., o/a, SM-D-282801, 80063 (Installed in equip)	2
5995-889-1304	1	Cable Assembly, Power, Electrical CX-1206/U, 2 No. 18 AWG cond, approx 6 ft 9 in. lg o/a, SC-D-25128, 80063	1,2
5995-161-2572	1	Cable Assembly, Power Electrical CX-120WU, 2 No. 18 AWG cond, approx 10 ft lg o/a, SC-D-25128, 80063	1,2
5995-296-1607	1	Cable Assembly, Radio Frequency CG-1368/U, 1 cond RG-58/U, one end PJ-055B, sec end Cannon XL-3-12,SM-C-28.3011, 80063	1,2
5965-296-9910	1	Headset, Electrical H-104/G, H-104A/G, Dynamic type, 300 ohms nonimpedance connected in parallel earphone, 2 in. dia x 1 in. d o/a, GA 5 ft lg with plug-in term	1,2
5965-296-3117	1	Microphone, Dynamic M-65/U, 150 ohms impedance, 100 to 10,000 Hz freq range (Not mounted)	1,2
5835-54343081	1	Recorder Reproducer Subassembly, Sound RD-149/TNH-2B, c/o l ea tape transport mechanism. recording head, reproducing head, 2 motors, single ph, 19 in. lg x 15-3/4 in. h x 6-1/2 in. deep (Installed in equip)	2
5835-543-0282	1	Reel, Sound, Recording Tape: STD 10-1/2 in. reel, American Moulded Products RETMA 10-1/2 in. (Installed in equip)	1,2
5820-5664668	1	Splicer, Magnetic Recording Tape, steel, 1-1/2 in. w 2-3/8 in. x 5-7/8 in, o/a dia. Robbins Ind part No. TS4	1,2
5835-393-1983	1	Tape, Leader Timing, Recorder Reproducer, paper, 3-3/4 in. lg x 1/4 in. w o/a. 43-1.5,76381	1,2
5835-583-1296	1	Tape, Sound Recording, 1/4 in. w, 2400 ft lg. Fed type TAT-A-FT-2400-250-PA	1,2
5835-537-7812	1	Tape, Splicing, Recorder Reproducer, plastic base, white, 0.50 in. w x 0.002 in. thk, 41-1/2L, 76381	1,2
		AMPLIFIER POWER SUPPLY AM-1634 /TNH-2B	
5935-187-0716	1	connector, Plug, Electrical, 10 male cont. 10 amps, 730v, P310-FHT, 71785 (Installed in equip)	
		RECORDER REPRODUCER SUBASSEMBLY SOUND RD-146/TNH-2A AND RECORDER REPRODUCER SUBASSEMBLY SOUND RD-149/TNH-2B	
5835-509-8442		Holder, Reel, used to mount reels of tape, TR+05, 30040 (Installed in equip)	



### 5.3. Expendable Consumable Items

A list of expendable consumable items required for operation appears in table 1-1.

Table 1-1. Expendable Consumable Supplies and Materials

The supplies and material listed in this table are required for operation of this equipment and are authorized to be requisitioned by SB 700-50. The FSN for the applicable unit of issue required can be found in appropriate supply catalogs. The FSCM is used as an element in item identification to designate manufacturer or distributor or Government agency, etc., and is identified in SB 708-42.

Item	Description	Ref No. and FSCM	FSC
1	Tape, Sound Recording, 1/4 in. w, 2400 ft lg.	TAT-A-FT-2400-250-PA, 81348	5835

Page 89. Appendix III is superseded as follows:

## APPENDIX III BASIC ISSUE ITEMS LIST

### Section I. INTRODUCTION

#### 1. Scope

This appendix lists basic issue items required by the crew/operator for installation, operation, and maintenance of Sound Recorder-Reproducer Sets AN/TNH-2A and AN/TNH-2B.

#### 2. General

This basic issue items list is a list, in alphabetical sequence, of items which are furnished with, and which must be turned in with the end item.

#### 3. Explanation of Columns

The following provides an explanation of columns found in the tabular listings:

*a. Illustration.* This column is divided as follows

(1) *Figure number.* Indicates the figure number of the illustration in which the item is shown.

(2) *Item number.* Not applicable.

*b. Federal Stock Number.* Indicates the Federal stock number assigned to the item and will be used for requisitioning purposes.

*c. Part Number.* Indicates the primary number used by the manufacturer (individual, company, firm, corporation, or Government activity), which controls the design and characteristics of the item by means of its engineering drawings, specifications standards, and inspection requirements, to identify an item or range of items.

*d. Federal Supply Code for Manufacturer (FSCM).* The FSCM is a 5 digit numeric code used to identify the manufacturer, distributor, or Government agency, etc., and is identified in SB 708-42.

*e. Description.* Indicates the Federal item name and a minimum description required to identify the item.

*f. Unit of Measure (U/M).* Indicates the standard of basic quantity of the listed item as used in performing the actual maintenance function. This measure is expressed by a two-character alphabetical abbreviation, (e.g., ea, in., pr, etc). When the unit of measure differs from the unit of issue, the lowest unit of issue that will satisfy the required units of measure will be requisitioned.

g. Quantity (Furnished with Equipment (Basic Issue Items Only). Indicates the quantity of the basic issue item furnished with the equipment.

models. Identification of the usable on codes are as follows:

Code	Used on
1	AN/TNH-2A
2	AN/TNH-2B

#### 4. Special Information

Usable on codes are included in description column. Uncoded items are applicable to all

### Section II. BASIC ISSUE ITEMS LIST

(1) Illustration		(2) Federal stock number	(3) Part number	(4) FSCM	(5) Description  Usable on code	(6) Unit of means	(7) Qty furn with equip
(A) Fig. no.	(B) Item no.						
1		5835-503-1643	SC-DL-292607	80063	CASE, AMPLIFIER 1.2 CY-1830/TNH-2A, 24-1/4 IN. LG x 20-1/4 IN. X 13-1/4 IN. H O/A	EA	1
		5835-503-1638	SC-DL-292567	<b>80063</b>	CASE, SOUND RECORDER REPRODUCER CY- 1831/TNH-2A, 20-1/2 IN. LG X 19-3/4 IN, W X 15- 3/4 IN. H, LUGGAGE TYPE CASE	EA	1

By Order of the Secretary of the Army:

CREIGHTON W. ABRAMS  
*General, United States Army  
Chief of Staff*

Official:

VERNE L. BOWERS  
*Major General, United States Army  
The Adjutant General*

Distribution:

*Active Army*

USASA (2)	Sig Dep (5)
CNGB(1)	USMA (2)
ACSC-E (2)	ATS (1)
Dir of Trans (1)	MAAG (1)
COE (1)	WRAMC (1)
TSG (1)	USARMIS (1)
USAARENBD ( 1 )	USA ERDAA (1)
USAMB (10)	USA ERDAW (1)
AMC (1)	Sig FLDMS (1)
MICOM (2)	Units org under fol TOE: 1 ea
TECOM (2)	6 - 3 0 2
FORSCOM (5)	7
ARADCOM (2)	7 - 4 2
ARADCOM Rgn (2)	11-16
OS Maj Cored (4)	11-97
LOGCOMD (3)	11-98
USA STRATCOM (4 )	11-117
MDW(1)	11-158
Armies (2)	11-500(AA-AC)
Corps (2)	12 - 3 2
HISA (ECOM) (18)	12-37
Instl (2) except	12-107
Ft Gordon (10)	12-157
Ft Huachuca (10)	1 7
Ft Carson (5)	17-42
USA CDCEC (10)	19-316
Svc colleges (1)	2 9 - 1
USASESS(5)	29 - 1 1
USAINTS (3)	29-21
USAADS (2)	29 - 5 2
USAFAS (2)	29-56
USAARMS (2)	29-134
USAIS (2)	29-136
USAES (2)	30-600
AD (2) except	33-500
SAAD (30)	3 7
LBAD (14)	37-42
TOAD (14)	4.5-500
ATAD (10)	5 1 - 1
Gen Dep (2)	52-1
Six Sec. Gen Dep (5)	5 7

*ARNG*: State AG (3)

*USAR*: None.

For explanation of abbreviations used. see AR 310-50.



SOUND RECORDER-REPRODUCER SETS AN/TNH-2A AND AN/TNN-2B

CHANGE

No. 7



HEADQUARTERS  
DEPARTMENT OF THE ARMY  
WASHINGTON, D.C., 1 July 1964

TM11-2583A, 30 January 1956, is changed as follows:

Note. The parenthetical reference to a previous change (example: page 1 of C 6) indicates that pertinent material was published in that change:

Page 1, paragraph 2 (page 1 of C 6). Delete subparagraph c and substitute:

*c. Reporting of Equipment Manual Improvements.* The direct reporting, by the individual user, of errors, omissions, and recommendations for improving this manual, is authorized and encouraged. DA Form 2028 (Recommended Changes to DA Publications) will be used for reporting these improvements. This form will be completed in triplicate using pencil, pen, or typewriter. The original and one copy will be forwarded direct to Commanding Officer, U. S. Army Electronics Materiel Support Agency, ATTN: SELMS-MP, Fort Monmouth, N.J. 07703. One information copy will be furnished to the individual's immediate su-

pervisor (officer, noncommissioned officer, supervisor, etc.).

Page 83 (page 5 of C 6), last two lines. Change appendix II to appendix III; change section III to section II.

Appendix III, section II. Make the following changes:

(Page 6 of C 6), Federal stock number column, 5995-259-2090. Make the following changes: Federal stock number column, change 5995-259-2090 to 5995-889-1304. Description column, change approx 6 ft lg o/a to approx 6 ft 9 in lg o/a.

(Page 7 of C 6), Federal stock number column, 5835493-1983. Description column, change H3-L5 to 43-1.5.

By Order of the Secretary of the Army:

EARLE G. WHEELER,  
*General, United States Army,*  
*Chief of Staff.*

Official:

J. C. LAMBERT,  
*Major General, United States Army,*  
*The Adjutant General.*

Distribution:

*Active Army:*

USASA (2)  
CNGB (1)  
CofT (1)  
CofEngrs (1)  
TSG (1)  
CofSpts (1)  
C/COMMEL (7)  
USAARMBD (2)  
USAARTYBD (2)  
USARADB (5)  
USAAESWBD (5)  
USCONARC (5)  
USAMC (5)  
USAECOM (7)  
USAMICOM (4)  
USASMCOM (2)  
ARADCOM (2)  
ARADCOM Rgn (2)  
OS Maj Cored (3) except  
    USARSOUTHCOM (2)  
    USARYIS (2)  
OS Base Comd (2)  
LOGCOMD (2)  
MDW (1)  
Armies (2) except EUSA (5)  
Corps (2)  
USA Corps (3)  
11th Air Assault Div (3)  
nsth (2) except  
    Ft Monmouth (63)  
    Ft Hancock (4), Ft Gordon (5)  
    Ft Huachuca (10)  
    Ft Leavenworth (6)  
    Ft Devens, Ft Lee (6)  
    Camp LeRoy Johnson (5)  
Svc Colleges (2)  
Br Svc Sch (2) except  
    USAIS (20, USACSC (30),  
    USAADS, USAAVNS (20)  
USMA (20)  
USAWC (20)  
GENDEP (OS) (2)  
Sig Sec, GENDEP (OS) (5)  
Sig Dep (OS) (12)  
Army Dep (2) except Sharpe (3)  
    Lexington, Tobyhanna (12)  
    Sacramento (28), Ft Worth (8)  
    Letterkenny, Navajo (6)  
    Savanna (5), Utah (8)

Charleston (3), Atlanta (8)  
New Cumberland (8)  
USASCC (4)  
USAECDA (1)  
USACBRCDA (1)  
USACECDA (1)  
USACECDA (Monmouth Ofc) (1)  
USAMSCDA (1)  
USAOCD (1)  
USAQMCDA (2)  
USATCDA (1)  
USAADCDA (1)  
USAARMCDA (2)  
USAAVNCDA (1)  
USAARTYCDA (1)  
USASWCDA (1)  
USA Elct Mat Agcy (9)  
USASA 1st Fld Sta (5)  
USAPA (5)  
USATC AD (2)  
USATC Armor (3)  
USATC Engr (2)  
USATC Inf (3)  
USASTC (3)  
WRAMC (1)  
Army Pic Cen (2)  
BAMC (5)  
USASTC (S)  
USA SW Cen (5)  
Chicago Proc Dist (1)  
AMS (1)  
USAE LRDA (White Sands) (13)  
Army Tml (1) except Oakland (S)  
POE (1)  
Sig Fld Maint Shops (3)  
WSMR (5)  
USATTCARC (1)  
USATTCA (1)  
USATTG (1)  
USATTCP (1)  
USAERDL (2)  
USA Cold Rgn RE Lab (2)  
William Beaumont Gen Hosp (5)  
Valley Forge Gen Hosp (5)  
KMAG (5)  
Units org under fol TOE:  
    (2 copies each except as indicated)  
8-302  
7

7-42  
7-62  
10-22  
11-16  
11-57  
11-97  
11-98  
11-117  
11-155  
11-157  
11-500 (AA-AE) (4)  
11-557  
11-587  
11-592  
11-597  
12-32  
12-37  
12-107  
12-157  
17  
17-2  
17-42

17-62  
19-252  
19-266  
19-316  
29-1  
29-2  
29-11  
29-21  
29-61  
28-52  
29-56  
30-600 (AA-AE)  
33-500 (AA-AC)  
33-600 (AA-AC)  
37  
37-42  
45-500 (AA-AB)  
51-1  
52-1  
57  
67-6

*NC*: State AG (3).

*USAR*: None.

For explanation of abbreviations used, see AR 32O-5O.





TECHNICAL MANUAL  
SOUND RECORDER-REPRODUCER SETS AN/TNH-2A AND AN/TNH-2B

TM 11-2583A  
CHANGES No. 6

HEADQUARTERS,  
DEPARTMENT OF THE ARMY  
WASHINGTON 25, D.C., 7 June 1963

TM 11-2583A, 30 January 1956, is changed as follows:

*Note:* The parenthetical reference to previous changes (example: "page 1 of C 4") indicates that pertinent material was published in that changes.

*Page 1.* Make the following changes:

Paragraph 1. Add paragraph 1.1 after paragraph 1.

#### 1.1. Index of Publications

Refer to the latest issue of DA Pam 310-4 to determine whether there are new editions, changes, or additional publications pertaining to the equipment. DA Pam 310- is an index of current technical manuals, technical bulletins, supply bulletins, lubrication orders, and modification work orders that are available through publications supply channels. The index lists the individual parts (-10, -20, -35P, etc. ) and the latest changes to and revisions of each equipment publication.

Paragraph 2 (page 1 of C 4). Delete paragraph 2 and substitute:

#### 2. Forms and Records

*a. Reports of Maintenance and Unsatisfactory Equipment.* Use equipment forms and records in accordance with instructions in TM 38-750.

*b. Report of Damaged or Improper Shipment.* Fill out and forward DD Form 6 ( Report of Damaged or Improper Shipment) as prescribed in AR 700-58 (Army), NAVSANDA Publication 378 (Navy), and AFR 71-4 (Air Force).

*c. Comments on Manual.* Forward all comments on this publication direct to: Command-

ing Officer, U.S. Army Electronics Materiel Support Agency, ATTN: SELMS-MP, Fort Monmouth, N.J. (DA Form 1598 (Record of Comments on Publications), DA Form 2496 (Disposition Form), or letter may be used.)

*Page 24.* Delete paragraph 31 and substitute:

#### 31. Organizational Tools, Materials, and Test Equipment Required

The tools, materials, and test equipment required for organizational maintenance of Sound Recorder-Reproducer Sets AN/TNH-2A and AN/TNH-2B are listed below.

*a. Tools.* Tool Equipment TE-41.

*b. Materials.*

- (1) Cleaning compound (Federal stock No. 7930-395-9542) .
- (2) Cleaning cloth.
- (3) Petrolatum (PET).
- (4) Oil (OAI).
- (5) Fine sandpaper (supplied in Tool Equipment TE-41 ).

*c. Test Equipment.*

- (1) Scale, spring, 8-ounce.
- (2) Scale, spring, 32-ounce.
- (3) Multimeter AN/URM-105.
- (4) Test Set, Electron Tube TV-7/U.
- (5) Demagnetizer, Ampex No. 704.

• These changes supersede C 5, 4 May 1962.

Page 25. Delete paragraphs 32 through 34 and figures 14 and 15 and substitute:

**32. Scope of Operator's Maintenance**

The maintenance duties assigned to the operator of the recorder-reproducer set are listed below together with a reference to the paragraphs covering the specific maintenance function. The duties assigned do not require tools or test equipment other than those issued with the equipment.

- a. Daily preventive maintenance checks and services (par. 34).
- b. Weekly preventive maintenance checks and services (par. 34.1 ).
- c. Cleaning (par. 34.2).

**33. Operator's Preventive Maintenance**

Preventive maintenance is the systematic care, servicing, and inspection of equipment to prevent the occurrence of trouble, to reduce downtime, and to assure that the equipment is serviceable.

a. *Systematic Care.* The procedures given in paragraphs 34, 34.1, and 34.2 cover routine systematic care and cleaning essential to proper upkeep and operation of the equipment.

b. *Preventive Maintenance Checks and Services.* The preventive maintenance checks and services charts (pars. 34 and 34.1), outline functions to be performed at specific intervals. These checks and services are to maintain Army electronic equipment in a combat serviceable condition; that is, in good general (physical) condition and in good operating condition. To assist operators in maintaining combat serviceability, the charts indicate what to check, how to check, and what the normal conditions are; the *References* column lists the illustrations, paragraphs, or manuals that contain detailed repair or replacement procedures. If the defect cannot be remedied by the operator, higher echelon maintenance or repair is required. Records and reports of these checks and services must be made in accordance with the requirements set forth in TM 38-750.

**34. Daily Preventive Maintenance Checks and Services Chart**

Sequence No..	Item	Procedure	References
1	Recorder-reproducer set. . . . .	Check equipment for completeness and general condition.	Appx III.
2	Exterior surfaces. . . . .	Clean exterior surfaces of the equipment.	Para 34.2.
3	External receptacles . . . . .	Inspect external receptacles for breakage and firm seating.	
4	Glass. . . . .	Inspect front-panel glass windows for damaged housing, broken glass, physical damage, dust, or moisture.	
5	Knobs, controls, and switches	During operation (item 7), check knobs, controls, and switches for proper mechanical action. Action must be positive without backlash, binding, or scraping.	
6	Meter pointer . . . . .	During operation (item 7), check for sticking meter pointer movement.	
7	Operation . . . . .	During operation, be alert for any unusual performance, response, or condition.	

### 34.1. Weekly Preventive Maintenance Checks and Services Chart

Sequence No.	Item	Procedure	References
1	Cables.....	Inspect external cables for cuts, cracked, or gouged jackets, fraying, or kinks.	
2	Hardware.....	Inspect all exterior hardware for looseness and damage. The recorder-reproducer set cover, carrying handle, hinges, input binding posts, and all bolts and screws must be tight and not damaged.	
3	Preservation	Inspect the equipment to determine that it is free of bare spots, rust, and corrosion. If these conditions exist, refer to higher echelon for repair.	

### 34.2. Cleaning

Inspect the exterior of the recorder-reproducer set. The exterior surfaces should be clean, and free of dust, dirt, grease, and fungus.

*a.* Remove dust and loose dirt with a clean soft cloth.

*Warning:* Cleaning compound is flammable and its fumes are toxic. Provide adequate ventilation. Do not use near a flame.

*b.* Remove grease, fungus, and ground-in dirt from the cases; use a cloth dampened (not wet) with cleaning compound.

*c.* Remove dust or dirt from plugs and jacks with a brush.

*Caution:* Do not press on the meter face (glass) when cleaning; the meter may be damaged.

*d.* Clean the front panels, meters, and control knobs; use a soft clean cloth. If dirt is difficult to remove, dampen the cloth with water; use mild soap if necessary.

### 34.3. Scope of Organizational Maintenance

The maintenance duties assigned to the organizational repairman of the recorder-reproducer set are listed below together with a reference to the paragraph covering the specific maintenance function. The duties assigned re-

quire tools and test equipment as specified in paragraph 31.

*a.* Monthly preventive maintenance checks and services (par. 34.5).

*b.* Lubrication (par. 35).

*c.* Rustproofing and painting (par. 37).

*d.* Visual inspection (par. 39).

Electron tube replacement procedure (par. 40).

*f.* Fuse replacement (par. 41).

*g.* Troubleshooting by using equipment performance checklist (par. 42).

### 34.4. Monthly Maintenance

Perform the maintenance functions indicated in the monthly preventive maintenance checks and services chart (par. 34.5) once each month. A month is defined as approximately 30 calendar days of 8-hour-per-day operation. If the equipment is operated 16 hours a day, the monthly preventive maintenance checks and services should be performed at 15-day intervals. Adjustment of the maintenance interval must be made to compensate for any unusual operating conditions. Equipment maintained in a standby (ready for immediate operation) condition must have monthly preventive maintenance checks and services performed on it. Equipment in limited storage (requires service before operation) does not require monthly preventive maintenance.

**34.5. Monthly Preventive Maintenance Checks and Services Chart**

Sequence No.	Item	Procedure	References
1	Publications	Inspect manual for completeness and to see if it is in usable condition, without missing pages. Be sure that all Changes to the manual are on hand.	DA Pam 310-4.
2	Modification work orders	Check to see that all URGENT MWO's have been applied and that all ROUTINE MWO's have been scheduled.	DA Pam 310-4
3	Completeness.....	Check the equipment for completeness and general condition.	Appx III.
4	Cleanliness.....	Clean exterior surfaces of the equipment.	Par. 34-2.
5	Preservation.....	Inspect the equipment to determine that it is free of bare spots, rust, and corrosion.	Par. 37.
6	External receptacles. ....	Inspect external receptacles for breakage and firm seating.	
7	Glass. ....	Inspect front-panel glass windows for damaged housing, broken glass, physical damage, dust, or moisture.	
8	Cables.....	Inspect external cables for cuts, cracked, or gouged jackets, fraying, or kinks.	
9	Hardware.....	Inspect all exterior and interior hardware for looseness and damage. The recorder-reproducer set cover, carrying handle, hinges input binding posts, and all bolts and screws must be tight and not damaged.	
10	Pilot lamps . . . . .	Check seating and condition of pilot lamps.	Fig. 12 and 13.
11	Fuses.....	The fuses in use should be 3 amperes, 250 volts, type F02G3R OOA (Federal stock number 5920-O10-6625).	Par. 41 and fig. 12 and 13.
12	Tubes . . . . .	Check seating of tubes.	Par. 40 and fig. 16 and 17.
13	Lubrication .....	Lubricate the equipment in accordance with paragraph 35.	
14	Knobs, controls, and switches	During operation (item 16), observe that the mechanical action of each knob, control, and switch is smooth and free of external or internal binding.	
15	Meter pointer . . . . .	During operation (item 16), check for sticking meter pointer movement.	
16	Performance. . . . .	Check the equipment performance checklist (par. 43).	Par. 43

Page 29. Delete paragraph 36.  
Delete paragraph 37 and substitute:

37. Rustproofing and Painting  
Remove rust and corrosion from metal sur-

faces by lightly sanding them with fine sandpaper. Brush two thin coats of paint on the bare metal to protect it from further corrosion. Refer to the applicable cleaning and refinishing practices specified in TM 9-213.

Page 89, appendix I and II (pages 1 and 8 of C 4). Renumber the existing appendixes as "II" and "III."

Add appendix "I" before appendix "II."

**APPENDIX I**  
**REFERENCE**

---

Following is a list of publications available to the operators and repairmen of Sound Recorder-Reproducer Sets AN/TNH-2A and AN/TNH-2B:

DA Pam 3104	Index of Technical Manuals, Technical Bulletins, Supply Bulletins, Lubrication Orders, and Modification Work Orders.
TM 9-213	Painting Instructions for Field Use.
TM 11-5097	Spectrum Analyzers TS-723A/U, TS-723B/U, and TS-723C/U.
TM 11-6625-203-12	Operation and Organizational Maintenance, Multimeter AN/URM-105, Including Multimeter ME-77/U.
TM 11-6625-218-12	Operation and Organizational Maintenance, Frequency Meter AN/TSM-16.
TM 11-6625-261-12	Operator's and Organizational Maintenance Manual, Audio Oscillators TS-382A/U, TS-382B/U, TS-382D/U, TS-382E/U, and TS-382F/U.
TM 11-6625-274-12	Operator's and Organizational Maintenance Manual, Test Sets, Electron Tube TV-7/U, TV-7A/U, TV-7B/U, and TV-7D/U.
TM 11-6625-316-12	Operator and Organizational Maintenance Manual, Test Sets, Electron Tube TV-2/U, TV-2A/U, TV-2B/U, and TV-2C/U.
TM 11-6625-320-12	Operator's and Organizational Maintenance Manual, Voltmeter, Meter ME-30A/U, and Voltmeters, Electron ME-30B/U, and ME-30C/U.
TM 38-750	The Army Equipment Records System and Procedures.

Appendix 11 (as added by C4, 17 October 1961 and changed by C 5, 4 May 1962). Delete section III and substitute:

**Section II. FUNCTIONAL PARTS LIST**

FEDERAL STOCK NUMBER	DESIGNATION BY MODEL	DESCRIPTION	UNIT OF ISSUE	EXP	QTY IN UNIT	ILLUSTRATION	
						FIG. NO.	ITEM NO.
		RECORDER-REPRODUCER SETS, SOUND AN/TNH-2A AND AN/TNH-2B					
5835-503-1512		RECORDER REPRODUCER SET, SOUND, AN/TNH-2A: magnetic recording tape type; med 0.250 in w; 15 in to 7.5 in per second recording speed; 40 to 10,000 cps $\pm$ 2 bd; freq response 8w; output, 600 ohms imped; Luggage case type; 115v, 60 cyc, single ph; Ampex part No. 402P		NX		1	
5835-543-0079		RECORDER REPRODUCER SET, SOUND, AN/TNH-2B: magnetic type; 600 ohms imped; tape type; 1/4 in w; 7-1/2 in and 15 in per sec; 50 to 10,000 cps $\pm$ 2 bd; 8w; 115v, 60 cyc, single ph; special features, provision for remote control Landers, Frary and Clark part No. 6320-14-0000		NX		1	
		NOTE: Model Column 1 refers to AN/TNH-2A; Column 2 refers to AN/TNH-2B.					
		ITEMS COMPRISING AN OPERABLE EQUIPMENT					
ORD THRU AGC	† †	TECHNICAL MANUAL TM 11-2583A				2	
5830-537-7755	† †	AMPLIFIER, AUDIO FREQUENCY AM-1249/U: 5w power output; 115v, 60 cyc, single ph; 1 channel input; 50,000 ohm impedance; Sig dwg No. SC-DL-282750 (Installed in equip)		NX		1 1	
5830-537-7756	†	AMPLIFIER POWER SUPPLY AM-1251/TNH-2A: provides amplification and erase signal for motor board assembly; 19 in lg x 7 in h x 14 in w o/a; Sig dwg SC-DL-282772 (Installed in equip)		NX		1 1	
5835-543-0080	†	AMPLIFIER POWER SUPPLY AM-1634/TNH-2B: AF amplifier; 8w output; 600 ohms impedance; Power Supply 1.6 amp 5v; 115v 60 cyc, single ph; 7 in x 14 in x 19 in o/a; Sig dwg No. SM-D-282801 (Installed in equip)		NX		1 1	
5995-259-2090	† †	CABLE ASSEMBLY, POWER, ELECTRICAL CX-1208/U: 2 No. 18 AWG cond; approx 6 ft lg o/a; Sig dwg No. SC-D-25128				1 4	
5995-161-2572	† †	CABLE ASSEMBLY, POWER ELECTRICAL CX-1208/U: 2 No. 18 AWG cond; approx 10 ft lg o/a; Sig dwg No. SC-D-25128				1 4	
5995-296-1607	† †	CABLE ASSEMBLY, RADIO FREQUENCY CQ-1368/U: 1 cond RQ-58/U; one end PJ-055B, sec end Cannon XL-3-12; Sig dwg SM-C-283011				1 4	
5835-503-1643	† †	CASE, AMPLIFIER CY-1835/TNH-2A: 24-1/4 in lg x 20-1/4 in w x 13-1/4 in h o/a; Sig dwg No. SC-DL-292607		NX		1 1	
5835-503-1638	† †	CASE, SOUND RECORDER REPRODUCER CY-1831/TNH-2A: 20-1/2 in lg x 19-3/4 in w x 15-3/4 in h; Luggage type case; Sig dwg No. SC-DL-292567		NX		1	
5965-296-9910	† †	HEADSET, ELECTRICAL H-104/G; H-104A/G: Dynamic type; 300 ohms nonimpedance connected in paralld earphones; 2 in dia x 1 in d o/a; Cord 5 ft lg with plug-in term		NX		1 4	
5965-296-3117	† †	MICROPHONE, DYNAMIC M-65/U: 150 ohms impedance; 100 to 10,000 cyc freq range (Not mounted)		NX		1 4	

AN/TNH-2A AND AN/TNH-2B

FEDERAL STOCK NUMBER	DESIGNATION BY MODEL					DESCRIPTION	UNIT OF ISSUE	EXP	QTY IN UNIT	ILLUSTRATION	
	1	2								FIG. NO.	ITEM NO.
						AN/TNH-2A AND AN/TNH-2B (continued)					
						RECORDER REPRODUCER SUBASSEMBLY, SOUND RD-146/TNH-2A: c/o tape transport mechanism, recording heads reproducing head, erasing head; 19 in lg x 15-3/4 in h x 6-1/2 in d; SigC dwg SC-DL-282901 (Installed in equip)			NX	1	
5835-543-0081						RECORDER REPRODUCER SUBASSEMBLY, SOUND RD-149/TNH-2B: c/o 1 ea tape transport mechanism, recording head, reproducing head, 2 motors, single ph; 19 in lg x 15-3/4 in h x 6-1/2 in deep; (Installed in equip)			NX	1	1
5835-521-5766						REEL, SOUND, RECORDING TAPE: Std 10-1/2 in reel; American Moulded Products RETMA 10-1/2 in (Installed in equip)					1 4
5820-566-0668						SPLICER, MAGNETIC RECORDING TAPE: steel; 1-1/2 in w 2-3/8 in x 5-7/8 in o/a dia; Robbins Ind part No. TS4					1 11.1
5835-393-1983						TAPE, LEADER TIMING, RECORDER REPRODUCER: paper; 3-3/4 in lg x 1/4 in w o/a; Min Mining type No. H3-1.5					1 4
5835-583-1296						TAPE, SOUND RECORDING: 1/4 in w; 2400 ft lg; Fed type TAT-A-FT-2400-250-PA					1 4
5835-537-7812						TAPE, SPLICING, RECORDER REPRODUCER: plastic base; white; 0.50 in w x 0.002 in thk; Min Mining type No. 41-1/2L					1 4
						AMPLIFIER POWER SUPPLY AM-1634/TNH-2B					
5935-187-0716						CONNECTOR, PLUG, ELECTRICAL: 10 male cont; 10 amps, 730v; Jones, H. B. type P310-FHT (Installed in equip)					1
						RECORDER REPRODUCER SUBASSEMBLY SOUND RD-146/TNH-2A AND RECORDER REPRODUCER SUBASSEMBLY SOUND RD-149/TNH-2B					
5835-509-8442						HOLDER, REEL: used to mount reels of tape; Telectro part No. TR-605 (Installed in equip)					2 1
						RUNNING SPARE ITEMS					
						RECORDER REPRODUCER SETS, SOUND AN/TNH-2A AND AN/TNH-2B					
5835-583-1296						TAPE, SOUND RECORDING: 1/4 in w; 2400 ft lg; Fed Spec No. TAT-A-FT-2400-250-PA					14 4
						AMPLIFIER AUDIO FREQUENCY AM-1249/U					
5960-262-0218						ELECTRON TUBE: MIL type 5Y3W0TA (Not mounted)					1 4
5960-116-9927						ELECTRON TUBE: MIL type 6V60TY (Not mounted)					1 4

AN/TNH-2A AND AN/TNH-2B

FEDERAL STOCK NUMBER	DESIGNATION BY MODEL					DESCRIPTION	UNIT O.F. EXP ISSUE	QTY UNIT	ILLUSTRATION	
	1	2							FIG. NO.	ITEM NO.
						AN/TNH-2A AND AN/TNH-2B (continued)				
5960-166-7664						ELECTRON TUBE : MIL type 12AX7		1	4	
5920-296-1517						FUSE, CARTRIDGE : 3 amp ; 250v MIL type F03G3R00A		5	4	
6240-155-8706						LAMP, INCANDESCENT : 6-8v; mazda bulb; MIL Spec MS-15571-2 type TB-14		1	4	
						AMPLIFIER POWER SUPPLY AM-1251/TNH AND AMPLIFIER POWER SUPPLY AN-1634/TNH-2B				
5960-262-0218						ELECTRON TUBE : MIL type 5Y3WG1A		1		4
5960-188-8500						ELECTRON TUBE: MIL type 6C5		1		4
5960-262-0163						ELECTRON TUBE: MIL type 6SN7WGTA		1		4
5960-248-1274						ELECTRON TUBE: MIL type 5879		1		4
5920-296-1517						FUSE, CARTRIDGE : 3 amp ; 250v; MIL F03G3R00A		5	4	
6240-155-8706						LAMP, INCANDESCENT: 6-8v; madza bulb; MIL Spec MS-15571-2 type TB-14		1	4	

AN/TNH-2A AND AN/TNH-2B



By Order of the Secretary of the Army:

EARLE G. WHEELER,  
*General, United States Army,  
Chief of Staff.*

Official:

J. C. LAMBERT,  
*Major General, United States Army,  
The Adjutant General.*

Distribution:

*Active Army:*

DASA (6)	Tobyhanna (12)
USASA (2)	USA Elct RD Actv, White Sands (13)
CNGB (1)	USA Elct RD Actv, Ft Huachuca (2)
CofEngrs (1)	USA Trans Tml Cored (1)
TSG (1)	Army Tml (1)
CSigO (5)	POE (1)
CofT (1)	USAOSA (1)
USA CD Agcy (1)	AMS (1)
USCONARC (5)	WRAMC (1)
USAMC (5)	AFIP (1)
ARADCOM (2)	Army Pic Cen (2)
ARADCOM Rgn (2)	USA Mbl Spt Cen (1)
OS Mai Cored (3)	USA Elct Mat Agcy (12)
OS Base Cored (2)	Chicago Proc Dist (1)
LOGCOMD (2)	USARCARIB Sig Agcy (1)
USAECOM (5)	Sig Fld Maint Shop (3)
USAMICOM (3)	c/Spt Svcs (1)
USASCC (4)	Units org under fol TOE:
MDW (1)	Two copies each UNOINDC:
Armies (2)	7 19-252
Corps (2)	7-62 19-256
USA Corps (3)	11-7 19-316
USATC AD (2)	11-16 29-1
USATC Engr (2)	11-57 29-21
USATC Inf (2)	11-97 29-56
USATC Armor (2)	11-117 30-600 (AA-AE)
Instls (2) except	11-155 32-51
Ft Monmouth (63)	11-157 32-56
Svc College (2)	11-500 (AA-AC) (4) 32-57
Br Svc Sch (2)	11-587 33-600 (AA-AC)
GENDEP (OS) (2)	11-592 45-500 (AA-AC)
Sig Dep (OS) (12)	11-597 51-1
Sig See, GENDEP (5)	12-32 52-1
Army Dep (2) except	12-107 57
Ft Worth (8)	12-157 57-6
Lexington (12)	17-2 57-6
Sacramento (28)	17-62

NG: State AG (3) ; units—same as active Army except allowance is one copy each unit.

USAR: None.

For explanation of abbreviations used, see AR 320-50.



TM 11-2583A  
TO 3153-2TNH2-21  
CHANGES No. 4

DEPARTMENTS OF THE ARMY AND  
THE AIR FORCE  
WASHINGTON 25, D.C., 17 October 1961

**SOUND RECORDER-REPRODUCER SETS AN/TNH-2A  
AND AN/TNH-2B**

TM 11-2583A, 30 January 1956, is changed as follows:

Page 1. chapter 1, Note (page 1 of C 2) (as changed by C 3, 16 Mar 59)

Line 4. Change "AM-1634/THN-2B" to AM-1634/TNH-2B.

Line 6. Change "RD-149/THN-2B" to RD-149/TNH-2B.  
Change "AN/THN-2B" to AN/TNH-2B.

Line 8. Change "AM-1634/THN-2B" to AM-1634/TNH-2B.

Line 11. Change "AN/THN-2B" to AN/TNH-2B.

Page 1, paragraph 2. Add subparagraph *d*.

*d. Comments or Suggestions.*

Any comments concerning omissions and discrepancies in Appendix I and Appendix II will be prepared on DA Form 2028 and forwarded direct to Commanding Officer, U.S. Army Signal Materiel Support Agency, ATTN: SIGMS-ML, Fort Monmouth, N.J.

*Figure .49* (foldout). (As changed by C 3, 16 Mar 59) Reverse the connections of terminals "B" and "D" of P103.

**APPENDIX I (ADDED)  
MAINTENANCE ALLOCATION  
RECORDER-REPRODUCER SET, SOUND  
AN/TNH-2A AND AN/TNH-2B**

\* These changes supersede C 3, 16 March 1959, and together with C1, 21 June 1961, TM 11-2583, 15 November 1954, supersede TM 11-5835-205-10P, 12 March 1959, including C 1, 2 May 1960, and so much of TM 11-5835 -205-20P, 12 March 1959, as pertains to maintenance allocation.

## SECTION I. INTRODUCTION

### 1. General

a. This appendix assigns maintenance functions to be performed on Components, assemblies, and sub-assemblies by the lowest appropriate maintenance echelon.

b. Columns in the maintenance allocation chart are as follows:

(1) *Component*. This column shows only the nomenclature or standard item name. Additional descriptive data is included only where clarification is necessary to identify the component. Components, assemblies, and sub-assemblies are listed in top-down order. That is, the assemblies which are part of a component are listed immediately below that component, and the sub-assemblies which are part of an assembly are listed immediately below that assembly. Each generation breakdown (components, assemblies, or sub-assemblies) are listed in disassembly order or alphabetical order.

(2) *Maintenance function*. This column indicates the various maintenance functions allocated to the echelons.

(a) *Service*. To clean, to preserve, and to replenish lubricants.

(b) *Adjust*. To regulate periodically to prevent malfunction.

(c) *Inspect*. To verify serviceability and to detect incipient electrical or mechanical failure by scrutiny.

(d) *Test*. To verify serviceability and to detect incipient electrical or mechanical failure by use of special equipment such as gages, meters, etc.

(e) *Replace*. To substitute serviceable components, assemblies, or sub-assemblies, for unserviceable components, assemblies, or sub-assemblies.

(f) *Repair*. To restore an item to serviceable condition through correction of a specific failure or unserviceable condition. This function includes but is not limited to welding, grinding, riveting, straightening, and replacement of parts other than the trial and error replacement of running spare type items such as fuses, lamps, or electron tubes.

(g) *Align*. To adjust two or more components of an electrical system so that their functions are properly synchronized.

(h) *Calibrate*. To determine, check, or rectify the graduation of an instrument, weapon, or weapons system, or components of a weapons system.

(i) *Overhaul*. To restore an item to *completely serviceable* condition as prescribed by serviceability standards developed and published by heads of technical services. This is accomplished through employment of the technique of "Inspect and Repair Only as Necessary" (IROAN). Maximum utilization of diagnostic and test equipment is combined with minimum disassembly of the item during the overhaul process.

(j) *Rebuild*. To restore an item to a standard as near as possible to original or new condition in appearance, performance, and life expectancy. This is accomplished through the maintenance technique of complete disassembly of the item, inspection of all parts or components, repair or replacement of worn or unserviceable elements using original manufacturing tolerances and/or specifications and subsequent reassembly of the item.

(3) 1st, 2d, 3d, 4th, 5th echelon. The symbol X indicates the echelon responsible for performing that particular maintenance operation, but does not necessarily indicate that repair parts will be stocked at that level. Echelons higher than the echelon marked by X are authorized to perform the indicated operation.

(4) Tools required. This column indicates codes assigned to each individual tool equipment, test equipment, and maintenance equipment referenced. The grouping of codes in this column of the maintenance allocation chart indicates the tool, test, and maintenance equipment required to perform the maintenance function.

(5) Remarks. Entries in this column will be utilized when necessary to clarify any of the data cited in the preceding columns.

c. Columns in the allocation of tools for maintenance functions are as follows:

(1) Tools required for maintenance functions. This column lists tools, test, and mainte-

ance equipment required to perform the maintenance functions.

- (2) *1st, 2d, 3d, 4th, 5th echelon.* The dagger (†) symbol in these columns indicates the echelons normally allocated the facility.
- (3) *Tool code.* This column lists the tool code assigned.

## **2. Maintenance by Using Organizations**

When this equipment is used by signal services organizations organic to theater headquarters or communication zones to provide theater communications, those maintenance functions allocated up to and including fourth echelon are authorized to the organization operating this equipment.

## SECTION II MAINTENANCE ALLOCATION CHART

(1)	(2)	(3)	(4)	(5)	(6)	(7)	(8)	(9)
PART OR COMPONENT	MAINTENANCE FUNCTIONS	1ST CCH	2ND CCH	3RD CCH	4TH CCH	5TH CCH	TOOLS REQUIRED	REMARKS
RECORDER-REPRODUCED SET, SOUND AN/TNI-2A; AN/TNI-2B	service	X	X				12 11	Exterior
	adjust	X	X				1,2,12,14	Operational adjustment Internal (Level adjustments)
	inspect	X	X				11	Exterior
	test	X	X				12	Operational
	repair overhaul		X		X		14 3	
AMPLIFIER, AUDIO FREQUENCY AM-1249/U	service	X	X				14	Clean externally
	inspect	X					11	Fuse, Pilot light external components Internal components
	test		X	X			8,10,14 3,4,5,7,10,11	Continuity, tubes, voltage General operation of components including output levels and distortion measurements
	replace repair overhaul		X	X	X		3,4,5,7,8,10,11 14 3 3	Final testing. Use tool code 9 in lieu of 10 for fifth echelon
						X		
AMPLIFIER-POWER SUPPLY GROUP AM-1251/TNI (P/O AN/TNi-2A ONLY)	service	X	X				14	Cleans externally
	adjust	X		X			3,5,11,13	Controls in course of operation Internal level controls
	inspect	X	X				14	Fuse, lamp Internal components
	test		X	X			8,10,11 3,4,5,7,10,11	Continuity, voltage, tubes General operation incl'd output levels and distortion measurement
	replace repair overhaul		X	X	X		3,4,5,7,8,10,11 14 3 3	Final testing. Use tool code 9 in lieu of 10 for fifth echelon
					X			

AN/TNI-2&amp; AN/TNI-2B 2

(1)	(2)	(3)	(4)	(5)	(6)	(7)	(8)	(9)
PART OR COMPONENT	MAINTENANCE FUNCTION	1ST 1.11	2ND 1.11	3RD 1.11	4TH 1.11	5TH 1.11	TOOLS REQUIRED	REMARKS
AN/TN1 2A; AN TN1 2B (Continued)								
AMPLIFIER-POWER SUPPLY AN-1631 TN1-2B (P O AN TN1-2B ONLY)	service	X	—	—	—	—	11	Cleans external components
	adjust	X	X	—	—	—	3,5,11,13	Controls in course of operation Internal level controls
	inspect	X	—	X	—	—	11	Fuse, lamp Internal components
	test	—	X	X	—	—	8,10,11	Continuity voltage, tubes
					X	—	3,4,5,7,10,11	General operation incl. output level and distortion measurements
						X	3,4,5,7,8,10,11	Final testing, use tool code 9 in lieu of 10 for fifth echelon
	replace		X	—	—	—	14	
	repair		—	X	—	—	3	
	overhaul		—	—	X	—	3	
CABLE ASSEMBLIES, POWER ELECTRICAL	repair			X	—	—	3	
CASE AMPLIFIER CY-1830 TN1-2A	replace			—	—	—	14	
	repair			X	—	—	3	
CASE, SOUND RECORDER-REPRODUCER CY-1831 TN1-2A; CY-1831/TN1-2B	replace			—	X	—	3	
HEADSET, ELECTRICAL H-104/G	replace	X			—	—		See separate MAC
MICROPHONE, DYNAMIC M-65/U	replace	X			—	—		See separate MAC

AN TN1-2A; AN TN1-2B





## SECTION III ALLOCATION CONTRCLS FOR MAINTENANCE FUNCTIONS

(1)	(2)	(3)	(4)	(5)	(6)	(7)	(8)
TOOLS REQUIRED FOR MAINTENANCE FUNCTIONS	1ST CCH	2ND CCH	3RD CCH	4TH CCH	5TH CCH	TOOL CODE	REMARKS
AN/TN1-2A; AN/TN1-2B (continued)							
SCALE, SPRING 8 OZ. FSN 6670-599-5296		†	†	†	†	1	
SCALE, SPRING 32 OZ. FSY 6670-291-8721		†	†	†	†	2	
TOOL EQUIPMENT TE-87/U			†	†	†	3	
SPECTRUM ANALYZER TS-733/U			†	†	†	4	
AUDIO OSCILLATOR TS-382A/U			†	†	†	5	
FLUTTER, INDICATOR PH-593/PFQ				†	†	6	
FREQUENCY METER AN/TSM-16			†	†	†	7	
MULTIMETER AN/URM-105		†	†	†	†	8	To be standardized
TEST SET, ELECTRON TUBE TV-2/U					†	9	
TEST SET, ELECTRON TUBE TV-7/U		†	†	†		10	
VOLTMETER ME-30/U			†	†	†	11	
DEMAGNETIZER AMPEX NO. 704	†	†	†	†	†	12	
TAPE ALIGNMENT IS TPS AMPEX NO. 4494			†	†	†	13	
TOOL EQUIPMENT TE-41		†				14	
0-12 LBS SCALE FSN 6670-001-9013			†	†	†	15	

## APPENDIX II (Added)

### BASIC ISSUE ITEMS FOR RECORDER-REPRODUCER SETS, SOUND AN/TNH-2A AND AN/TNH-2B

#### Section I. INTRODUCTION

##### 1. Scope

a. This appendix lists items supplied for initial operation and for running spares. The list includes tools, accessories, parts, and material issued as part of the major end item. The list includes all items authorized for basic operator maintenance of the equipment. End items of equipment are issued on the basis of allowances prescribed in equipment authorization tables and other documents that are a basis for requisitioning.

b. Columns are as follows

- (1) *Source, maintenance, and recoverability code.* Not used.
- (2) *Federal stock number.* This column lists the 11-digit Federal stock number.
- (3) *Designation by model.* The dagger (†) indicates the model in which the part is used.
- (4) *Description.* Nomenclature or the standard item name and brief identifying data for each item are listed in this column. When requisitioning, enter the nomenclature and description.
- (5) *Unit of issue.* The unit of issue is each, unless otherwise indicated, and is the supply term by which the individual item is counted for procurement, storage, requisitioning, allowances, and issue purposes.
- (6) *Expendability.* Nonexpendable items are indicated by NX. Expendable items are not annotated.
- (7) *Quantity authorized.* Under "Items Comprising an Operable Equipment," the column lists the quantity of items supplied for the initial operation of the equipment. Under "Running Spares and Accessory Items," the quantities listed are those issued initially with the equipment as spare parts. The quantities are authorized to be kept on hand by the operator for maintenance of the equipment.
- (8) *Illustration.* The "Item No." column lists the reference symbols used for identification of the items in the illustration or text of the manual.

##### 2. References

Additional instructions concerning maintenance of this equipment are contained in:

Operator and Organizational Maintenance Repair Parts and Special Tools List and Maintenance Allocation Chart:

TM 11-5965-217-12P, Microphone, Dynamic M-65/U

Operator, Organizational, Field and Depot Maintenance Repair Parts and Special Tools Lists and Maintenance Allocation Chart:

TM 11-5965-210-15P, Headset, Electrical H-104/G, H-104A/G, H-104B/G

SECTION II FUNCTIONAL PARTS LIST

(1)	(2)	(3)	(4)	(5)	(6)	(7)	(8)	(9)
SOURCE MAINTENANCE AND RECOVERABILITY CODE	FEDERAL STOCK NUMBER	DESIGNATION BY MODEL	DESCRIPTION	UNIT OF ISSUE	EXPENDABILITY	QUANTITY AUTHORIZED	ILLUSTRATIONS	
							FIGURE NO	ITEM NO
		††	RECORDER-REPRODUCER SET SOUND, AN/TMI-2A: magnetic recording tape type, med 0.350 in w; 15 in to 7.5 in per recording speed 40 to 10,000 cps ± 2 db; fren response 8 w output, 600 ohms impeded; Luggage case type: 115 v, 60 cyc single ph; Ampex model No. 402P		NX			
	5835-543-0079		RECORDER-REPRODUCER SET, SOUND AN/TMI-2B: magnetic type; 600 ohms Impedance; tape type; 1/1 in w; 7 1/2 in and 15 in per see; 50 to 10,000 cps ± 2 db fren response 8 w; 117 v 60 eye, single ph; spcl features, provision for remote control		NX			
			ITEMS COMPRISING AN OPERABLE EQUIPMENT					
			NOTE: Model column 1 refers to AN/TMI-2A: Column 2 refers to AN/TMI-2B					
	Ord thru AGC	††	TECHNICAL MANUAL TM 11-2583A:			2		
	5830-537-7755	††	AMPLIFIER, AUDIO FREQUENCY AM-1249/U: 5 w power output; 117 v. 60 eye, single p channel input; 50,000 ohm impedance; Sig Corp dwg DL-282750 (Installed in equip)		NX	1		
	5830-537-7756	†	AMPLIFIER-POWER SUPPLY AM-1251 /TMI-2A: provides amplification and erase signal for motor board assembly; 19 in lg x 7 in h x 14 in w o/a; Sig dwg SC-DL-282772 (Installed in equip)		NX	1		
	5835-543-0080	†	AMPLIFIER-POWER SUPPLY, AM-1631 /TMI-2B: AF amplr; 8 w output; 600 ohms impedance; Power-Supply 1.6 amp, 5 v, 117 v, 60 cyc single ph; 7 in x 14 in x 19 in o/a; Telectro part No. TA-543A (Installed in equip)		NX	1		
	5995-259-2090	††	CABLE ASSEMBLY, POWER, ELECTRICAL CX-1208/U: 2 cond; approx 6 ft lg o/a; 2 No. 18 AWG Sig Corp dwg SC-D-25128 (Not installed)			1		
	5995-161-2572	††	CABLE ASSEMBLY, POWER, ELECTRICAL CX-1208/U: 2 cond; approx 10 ft lg o/a; 2 No. 18 AWG; Sig Corp dwg SC-D-25128 (Not installed)			1		
	5995-296-1607	††	CABLE ASSEMBLY, RADIO FREQUENCY CG-1368/U: 1 cent, RG-58/U; 6 ft lg o/a; one end PJ-0558, sec end Cannon XL-3-12; Tektro Ind part TC-1383 (Not installed)			1		
	5835-503-1643	††	CASE, AMPLIFIER CY-1830/TMI-2A: 24 1/4 lg x 20 1/4 in w x 13 1/4 in h o/a; Sig dwg DL-292607 (Not installed)		NX	1		
	5835-503-1638	††	CASE, SOUND RECORDER-REPRODUCER CY-1831/TMI-2A: 20 1/2 in lg x 19 3/4 in w x 15 3/4 in h o/a; Luggage type case; Sig dwg SC-DL-292567 (Not installed)		NX	1		
	5965-296-9910	††	HEADSET, ELECTRICAL H-104/G: Dynamic type; 300 ohms non-impedance connected in paralld-earphones 2 in dia x 1 in d o/a; Cord 5 ft lg with plug-in term (Not installed)		NX	1		

(1)	(2)	(3)	(4)	(5)	(6)	(7)	(8)	(9)
SOURCE MAINTENANCE AND RECOVER- ABILITY CODE	FEDERAL STOCK NUMBER	DESIGNA- TION BY MODEL	DESCRIPTION	UNIT OF ISSUE	EXPENDABILITY	QUANTITY AUTHORIZED	ILLUSTRATIONS	
							FIGURE NO.	ITEM NO
		††	AN/TMI-2A, AN/TMI-2B (continued)					
	5965-296-3117	††	MICROPHONE, DYNAMIC M-65/U: 150 ohms impedance 100 to 10,000 cyc freq range (Not installed)		NX	1		
	5835-537-7788	†	RECORDER-REPRODUCER SUB ASSEMBLY RD-146/TMI-2A: c/o tape transport mechanism, recording head, reproducing head, erasing head; 19 in lg x 15 3/1 in h x 6 1/2 in deep; Sig Corp dwg SC-DL-282901 (Installed in equip)		NX	1		
	5835-543-0081	†	RECORDER-REPRODUCER SUB-ASSEMBLY, SOUND RD-149/TMI-2B: c/o 1 ea tape transport mechanism, recording head, reproducing head, 2 motors, single ph: 6 1/2 in x 15 3/4 in x 19 in o/a dim; remote operations; Telectro part No. TA-542A		NX	1		
	5835-521-5766	††	REEL, SOUND, RECORDING TAPE: std 10 1/2 in reel; American Molded Products RETMA 10 1/2 in (Installed in equip)			1		H414
	5820-566-0668	††	SPLICER, MAGNETIC RECORDING TAPE: steel; 1 1/2 in by 2 3/8 in by 5 7/8 in o/a dia; Robbins Ind part TS4 (Not installed)			1		
	5835-393-1983	††	TAPE, LEADER TIMING, RECORDER, REPRODUCER: paper; 3 3/4 in lg x 0.250 in w; Min Mining type No. 43-1,5 (Not installed)			1		MS2
	5635-583-1296	††	TAPE, SOUND RECORDING: 1/4 in w; 2400 ft lg; Fed type TAT-A-FT-2400-250-PA (Not installed)			1		H415
	5835-537-7812	††	TAPE, SPLICING, RECORDER-REPRODUCER: plastic; base; white: 0.50 w x 0.002 in thk; Spool2 in cd x 1 1/16 in id x 1/2 in thk o/a; Minn Mining type No. 41-1/21. (Not installed)			1		
			AMPLIFIER-POWER SUPPLY GROUP AM-1634 /TMI-2B					
	5935-187-0716		CONNECTOR, PLUG, ELECTRICAL: 10 male cent; 10 amps 730 v; Jones type P310-FMT (Installed in equip)			1		J107
			RECORDER-REPRODUCER SUB-ASSEMBLY RD-146/TMI-2A AND RECORDER-REPRODUCER SUB-ASSEMBLY, SOUND RD-149/TMI-2B					
	5835-509-8442		HOLDER, REEL: used to mount reels of tape; Telectro Ind Corp part/dwg No. TR-605 (Installed in equip)			2		0264 0265

(1)	(2)	(3)	(4)	(5)	(6)	(7)	(8)	(9)
SOURCE MAINTENANCE AND RECOVERABILITY CODE	FEDERAL STOCK NUMBER	DESIGNATION BY MODEL	DESCRIPTION	UNIT OF ISSUE	DEPENDABILITY	QUANTITY AUTHORIZED	ILLUSTRATIONS FIGURE NO.	ITEM NO.
			AN/TMI-2A, AN/TMI-2B (continued)					
			RUNNING SPARES AND ACCESSORY ITEMS					
			RECORDER-REPRODUCER SET, SOUND AN/TMI-2A, AN/TMI-2B					
	5835-583-1296		TAPE, SOUND RECORDING: 1/4 in w; 2400 ft lg; Fed spec No: TAT-A-FT-2400-250-PA (Not mounted)			14		
			AMPLIFIER-AUDIO FREQUENCY AM-1249/U					
	5960-262-0218		ELECTRON TUBE MIL type 5Y3WGTA (Not mounted)			1		V301
	5960-116-9927		ELECTRON TUBE: MIL type 6V6GT (Not mounted)			1		V303
	5960-166-7664		ELECTRON TUBE: MIL type 12AX7 (Not mounted)			1		V304
	5920-010-6652		FUSE, CARTRIDGE: 3 amps, 250 v; MIL-F-15160 type F02G3800A (Not mounted)			5		
	6240-155-8706		LAMP, INCANDESCENT 6-8 v Mazda bulb; GE part No. 47 (Not mounted)			1		
			AMPLIFIER-POWER SUPPLY GROUP AM-1251 /TMI-2A AND AMPLIFIER-POWER SUPPLY GROUP AM-1634 /TMI-2B			1		
						1		
	5960-262-0218		ELECTRON TUBE: MIL type 5Y3WGTA (Not mounted?)			1		V103
	5960-188-8500		ELECTRON TUBE: MIL type 6C5 (Not mounted)			1		V106
	5960-188-3577		ELECTRON TUBE: MIL type 6SN7WGT (Not mounted)			1		V102
	5960-248-1274		ELECTRON TUBE: MIL type 5879 (Not mounted)			1		V107
								V101
								V104
								V105
	5920-010-6652		FUSE, CARTRIDGE: 3 amps, 250 v; MIL type MIL-F-15160, type F02G3800V (Not mounted]			5		F101
								F102
	6240-155-8706		LAMP, INCANDESCENT 6-8 v Mazda type; GE part No. 47 (Not mounted)			1		

G. H. DECKER,  
*General, United States Army,  
 Chief of Staff.*

Official:

J. C. LAMBERT,  
*Major General, United States Army,  
 The Adjutant General.*

CURTIS E. LEMAY,  
*Chief of Staff United States Air Force.*

Official:

R. J. PUGH,  
*Colonel, United States Air Force,  
 Director of Administrative Services.*

Distribution:

*Active Army:*

DASA (6)

USASA (2)

CNGB

Tech Stf, DA (1)

except CSigO (18)

Tech Stf Bd (1)

USCONARC (5)

USAARTYBD (1)

USAARMBD (2)

USAIB (1)

USARADB (2)

USAABELCTBD (1)

USAAVNBD (1)

USAATBD (1)

ARADCOM (2)

ARADCOM Rgn (2)

OS Maj Comd (3)

OS Base Cored (2)

LOGCOMD (2)

MDW (1)

Armies (2)

Corps (2)

Instl (2)

Ft Monmouth (63)

USATC AD (2)

USATC Armor (2)

USATC Engr (2)

USATC FA (2)

USATC Inf (2)

USAOMC (3)

Svc Colleges (2)

Br Svc Sch (2)

GENDEP (2) except

Atlanta GENDEP (None)

Sig Sec, GENDEP (5)

Sig Dep (12)

USA Trans TMI Cored (1)

Army Tml (1)

Valley Forge Gen Hosp (5)

William Beaumont Gen Hosp (5)

Blue Grass Ord Dep (5)

Erie Ord Dep (5)

Letterkenny Ord Dep (5)

Sierra Ord Dep (2)

Umatilla Ord Dep (3)

Red River Arsenal (5)

QMRECOMD (5)

USAEPPG (2)

AFIP (1)

AMS (1)

Army Pictorial Cen (2)

EMC (1)

Yuma Teat Sta (2)

USACA (3)

USASSA (20)

USASSAMRO (1)

USASEA (1)

USA Caribbean Sig Agcy (1)

USA Sig Msl Spt Agcy (13)

Sig Fld Maint Shops (3)

USA Corps (3)

JBUSMC (2)

AFSSC (1)

JCA (5)

USAPA (5)

USA SPWAR Cen (5)

USAWC (5)

Units org under fol TOE:

(2 cy each UNOINDC)

7

7-62

11-7

11-16

11-57

11-97

11-117

11-155

11-500 (AA-AE) (4)

11-557

11-587

11-592

11-597

12-32

12-107

12-157

17

17-2

17-62

19-252

19-256

19-316

29-56

30-600 (AA-AE)

32-51

32-56

32-57

33-77

33-600 (AA-AC)

45-500 (AA-AC)

51-1

57

57-5

57-6

NC: State AG (3); units-same as Active Army except allowance is one copy to each unit.

USAR: None.

For explanation of abbreviations used, see AR 320-50.

TECHNICAL MANUAL  
SOUND RECORDER-REPRODUCER SETS AN/TNH-2A AND AN/TNH-2B

TM 11-2583A }  
CHANGES No. 2 }

DEPARTMENT OF THE ARMY  
WASHINGTON 25, D. C., 17 January 1957

TM11-2583A, 30 January 1956, is changed as follows:

The title is changed to read: Sound Recorder-Reproducer Sets AN/TNH-2A and AN/TNH-2B.

The following information changes TM 11-2583A so that the manual applies also to the following equipment:

<i>Nomenclature</i>	<i>Order No.</i>	<i>Serial No.</i>
Sound Recorder-Reproducer Set AN/TNH-2B	43076-PH-56	1 through 192

*Page 1*, chapter 1. Add the following note at the beginning of the chapter:

Note. The components of Sound Recorder-Reproducer Set AN/TNH-2B are similar to the corresponding components of Sound Recorder-Reproducer Set AN/TNH-2A except that in addition Amplifier-Power Supply AM-1634/THN-2B and Sound Recorder-Reproducer S-assembly RD-149/THN-2B, components of the AN/THN-4-2B, provide for remote control operation. Ruggedized tubes are used in the AM-1634/THN-2B and in Audio Frequency Amplifier AM-1249/U (Order No. 43076-PH-56). All information in the manual applies equally to the AN/THN-2B unless otherwise specified.

Add "(6V6GT) on the AN/TNH-2B)" after "6V6GT" in the following places in the manual:

*Page 38*, paragraph 44c(3).

*Page 39*, figure 20.

*Page 65*, figure 35.

*Fold-out*, figure 48.

Add "(5Y3GTA on the AN/TNH-2B)" after "5Y3GT" in the following places in the manual:

*Page 37*, paragraph 44b(1).

*Page 38*, paragraph 44c(1).

*Page 65*, figure 35.

*Fold-out*, figure 48.

Add "(6SN7WGT) on the AN/TNH-2B)" after "6SN7" in the following places in the manual:

*Page 36*, figure 18.

*Page 37*, paragraph 44b (2).

*Page 37*, paragraph 44b (4).

*Page 44*, figure 24.

*Fold-out*, figure 49.

*Page 1*, paragraph 3a. Add the following after the last sentence:

Sound Recorder-Reproducer Set AN/TNH-2B provides for remote operation.

*Page 2*, paragraph 5. Make the following changes:

Change the paragraph heading to read: Table of Components of Sound Recorder-Reproducer Set AN/TNH-2A (figs. 1-4) .

Delete the introductory sentence.

In the Required No. column of Power Cable Assembly CX-1208/U (6 ft 0 in.) change 2 to read: 1.

In the Component column) following Power Cable Assembly CX-1208/U (6 ft 0 in.) add: Power Cable Assembly CX-1208/U (10 ft 0 in.).

On the same line, add 1 in the Required No. column; add 120 in the width column.

In the Component column, after CX-1208/U, add: (6 ft 0 in.).

In the Component column, following CX-1208/U, add: CX-1208/U (10 ft 0 in.).

On the same line, in the Required No. column, add: 1; in the Depth column, add: 120.

5.1. Table of Component of Sound Recorder-Reproducer Set AN/TNH-2B

(figs.1-4)  
(Added)

Component	Required No.	Height (in.)	Depth (in.)	Width (in.)	Length (in.)	Volume (cu ft)	Weight (lb)
Amplifier Power Supply AM-1634/TNH-2B - - - - -	1	7	14	19	-----	1.1	25
Recorder-Reproducer Subassembly RD-149/TNH-2B	1	6½	15¾	19		1.2	39
Audio, Frequency Amplifier AM-1249/U - - - - -	1	10½	7	19		.8	19
Sound Recorder-Reproducer Case CY-1831/TNH-2A	1	16½	21	21		4.2	36
Amplifier Case CY-1830/TNH-2A - - - - -	1	14	24½	21½	-----	4.4	41
Dynamic Microphone M-65/U, consisting of: - - - -	1	14	6				
Dynamic Microphone M-44 A/U - - - - -	1	4½	2				
Microphone Stand MT-1583/U- - - - -	1	8	6				
Electrical Headset H-118/U- - - - -	1						
Raider Frequency Cable Assembly CG-1368/U - - - -	1	-----			72		
Power Cable Assembly CX-1208/U (6 ft 0 in.) - - - -	1		-----		72		
Power Case Assembly CX-1208/U (10 ft 0 in.) - - - -	1		----		120		
Special Purpose Electrical Cable Assembly CX-3322/U (20 ft 0 in.).	1		-----		240		
Remote control connector (male) (fig. 29.1) - - - - -	1						
Tape reels (15 w/tape, 1 empty)- - - - -	16	5/8		10½ (dia)	-----	.04	
Running spares consisting of:							
Tubes:							
1 2 A X 7 - - - - -	1						
5 8 7 9 - - - - -	1						
6 V 6 G T Y - - - - -	1						
5 Y 3 G T A - - - - -	1						
6 S N 7 W G T - - - - -	1						
6 C 5 - - - - -	1						
Fuses: 3 amp - - - - -	5						
Pilot lamps - - - - -	5						
Cables:							
CX-1208/U (6 ft 0 in.) - - - - -	1	-----	-----	-----	72		
CX-1208/U (10 ft 0 in.) - - - - -	1			-----	120		

Page 9, paragraph 6b. After the third sentence, add: A female connector and a mating male connector are located on the rear of the chassis of Amplifier-Power Supply AM-1634/TNH-2B. The male connector, furnished with the equipment, when inserted, prepares the equipment for local operation. When removed, the remote control circuit of the recorder-reproducer set is opened. Insertion of the male connector of the remote control device (not furnished) arranges this circuit for remote control operation of the equipment.

Page 5, figure 4 (CI). Add the following note to figure 4:

NOTE. ON THE AN/TNH-2B, ONLY 5 SPARE FUSES AND 5 SPARE PILOT LAMPS ARE SUPPLIED: A SPARE SOUNDHEAD ASSEMBLY IS NOT SUPPLIED.

Page 6, paragraph 6.

i. 1. (Added) Power cable Assembly CX-1208/U (10 ft 0 in.): This cable is a two-conductor, rubber-covered, 10-foot cable, one end of which is terminated with a female connector and the other = terminated with a male connector.

Page 3, paragraph 7. Make the following changes.

Change Recorder-Reproducer Subassembly RD-1461/TNH-2A to read: **Recorder-Reproducer Subassembly RD-146/TNH-2A.**

Change the last item in the chart to read: **Power Cable Assembly CX-1208/U (10 ft 0 in.).**

Add the following note to figures 6, 8, 9, 10, 11, 12, 27, 28, 29, and 42:



*NOTE. ON THE AN/TNH-2B, A REMOTE CONTROL CONNECTOR IS LOCATED TO THE LEFT OF THE POWER CABLE CONNECTOR AT THE REAR OF THE AMPLIFIER CHASSIS.*

**21.1. Remote Operation of AN/TNH-2B**

(Added)

To use the AN/TNH-2B with remote control, proceed as follows:

a. Connect the equipment for the type of operation desired (pars. 11 and 13).

b. Remove the remote control male connector (furnished with the equipment), from the rear of the amplifier chassis.

c. Insert the remote control unit male connector into the 10-contact female connector on the rear of the amplifier chassis.

d. Adjust the equipment controls (fig. 13) for the type of operation desired (pars. 13-23).

e. Operate the recorder-reproducer set using the remote control unit.

f. When remote operation is completed, remove the remote control unit male connector from the rear of the amplifier chassis.

g. Insert the male connector (b above) into the female connector on the rear of the amplifier chassis.

Page 24, paragraph 29a: Add the following at the end of the chart:

Item	Function
Remote control connector	Provides a connection for remote control operation.

Page 24, paragraph 30. In the second sentence, after "authorized", insert: by.

Page 33, paragraph 43. Add the following after the paragraph heading:

Note. On the AN/TNH-2B, make sure the remote control connector, (furnished with the equipment), is inserted in its receptacle ( rear of amplifier) (fig, 29.1) before checking the equipment as indicated in the check list below.

Page 40, paragraph 49. Make the following changes:

In a, last sentence, change "capacitators" to read: capacitor.

In c, after the third sentence, insert: (On the AN/TNH-2B, the dc circuit of solenoid

L202 is closed through Switch S208 through contacts H and F of connectors P205 (fig. 50.1) and P103 (fig. 49.1), and contacts 7 and 8 of connectors P105 and J107.

Page 41, paragraph 50b. After the second sentence, insert: (On the AN/TNH-2B, the 115-vol dc output of rectifier CR201 is connected to the coil of relay K202 through switches S202 and S201, and through contacts H and F of connectors P205 and P103, through contacts 7 and 8 of connectors P105 and J107, and through switch S207 (figs. 49.1 and 50.1. ).)

Page 41, paragraph 51b. After the first sentence, insert: (On the AN/TNH-2B, the dc output of the rectifier is connected to the high side of the coil of relay K203 through switches S202 and S201, through contacts H and F of connectors P205 and J 107, and contacts 7 and 8 of connectors P105 and J107, switch S205, and through contacts 7 and 8 of relay K202). )

Page 47, paragraph 57b. Make the following changes:

Tenth line, change "R304" to read: R302.

Eleventh line, change "R304" to read: R302.

Page 47, figure 26. Designate reference symbol R303, and a value of 220 ohms to the cathode resistor of tube V302A.

Page 49, paragraph 60. Insert the following in the list:

Fig. No.	Title
29.1	Part of amplifier chassis (AM-1634/TNH-2B), bottom view, showing connectors for remote operation.
30.1	Amplifier chassis (AM-1634/TNH-2B), resistor-capacitor board (nearer to panel).
31.1	Amplifier chassis (AM-1634/TNH-2B), resistor-capacitor board (farther from panel).
34.1	Voltage and resistance chart, amplifier (AM-1634/TNH-2B).
49.1	Amplifier (AM-1634 TNH-2B), schematic diagram.
50.1	Recorder-reproducer (RD-149/TNH-2B), schematic diagram.
62.1	Amplifier (AM-1634/TNH-2B), wiring diagram.
53.1	Recorder-reproducer (RD-149/TNH-2B), wiring diagram.

Page 51, paragraph 63. Make the following Changes:

In the heading, change (fig. 27,28,29,30, and 31) to read: (figs. 27, 28, 29, 29.1, 30, anti 31).

In *a*, at the end of the first sentence, insert:  
On the AM-1634/TNH-2B, measure the resistance between pins D and G of connector P 103.

In *f*, after "figure 34", add: or figure 34.1.

In *g*, after "figure 34", add: or figure 34.1.

Page 57, paragraph 65. Add the following opposite "symptom No. 1":

Probable cause	Remedy
Defective connector P105.	Replace connector P105.
Defective connector J107.	Replace connector J107.

Page 63, paragraph 67d At the end of the subparagraph, after "34," insert: 34.1.

Page 63, paragraph 69. Under the paragraph heading, after "49," add: and 49.1.

Page 64, figure 34. Make the following changes:

Pin 7 of XV103. Substitute 3.15 AC for "20".

Pin 8 of XV103. Substitute 20 for "3.15 AC".

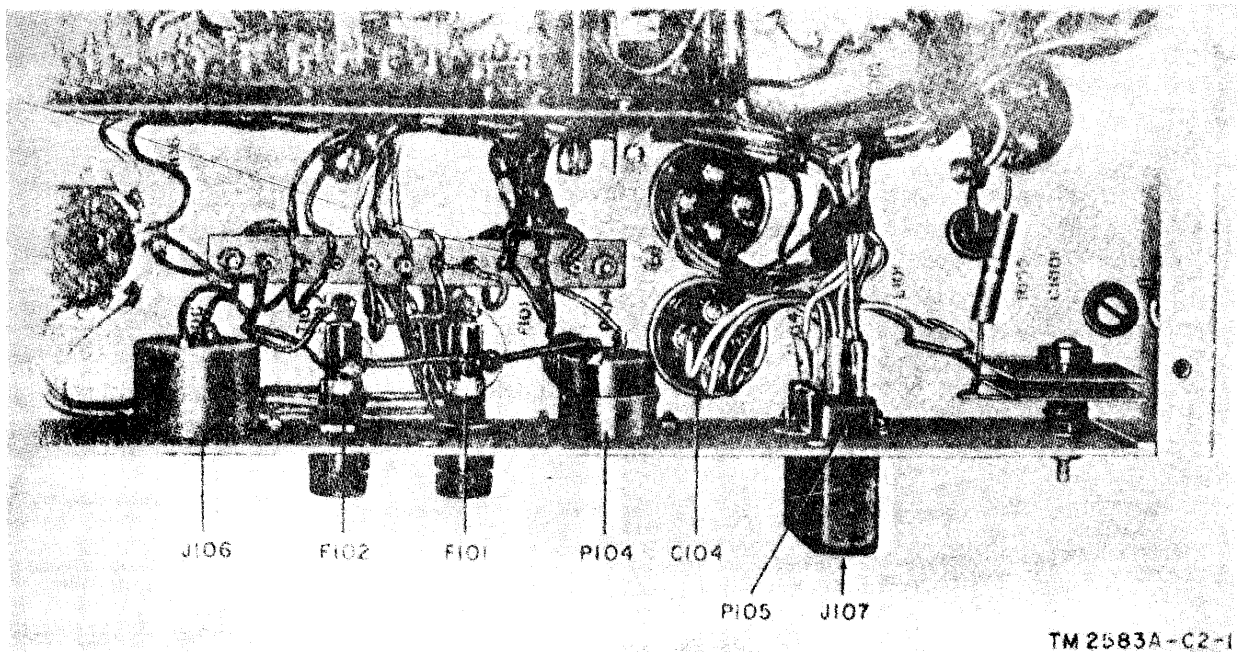

Figure 29.1. (Added) Part of amplifier chassis (AM-1634/TNH-2B), bottom view, showing connectors for remote operation.

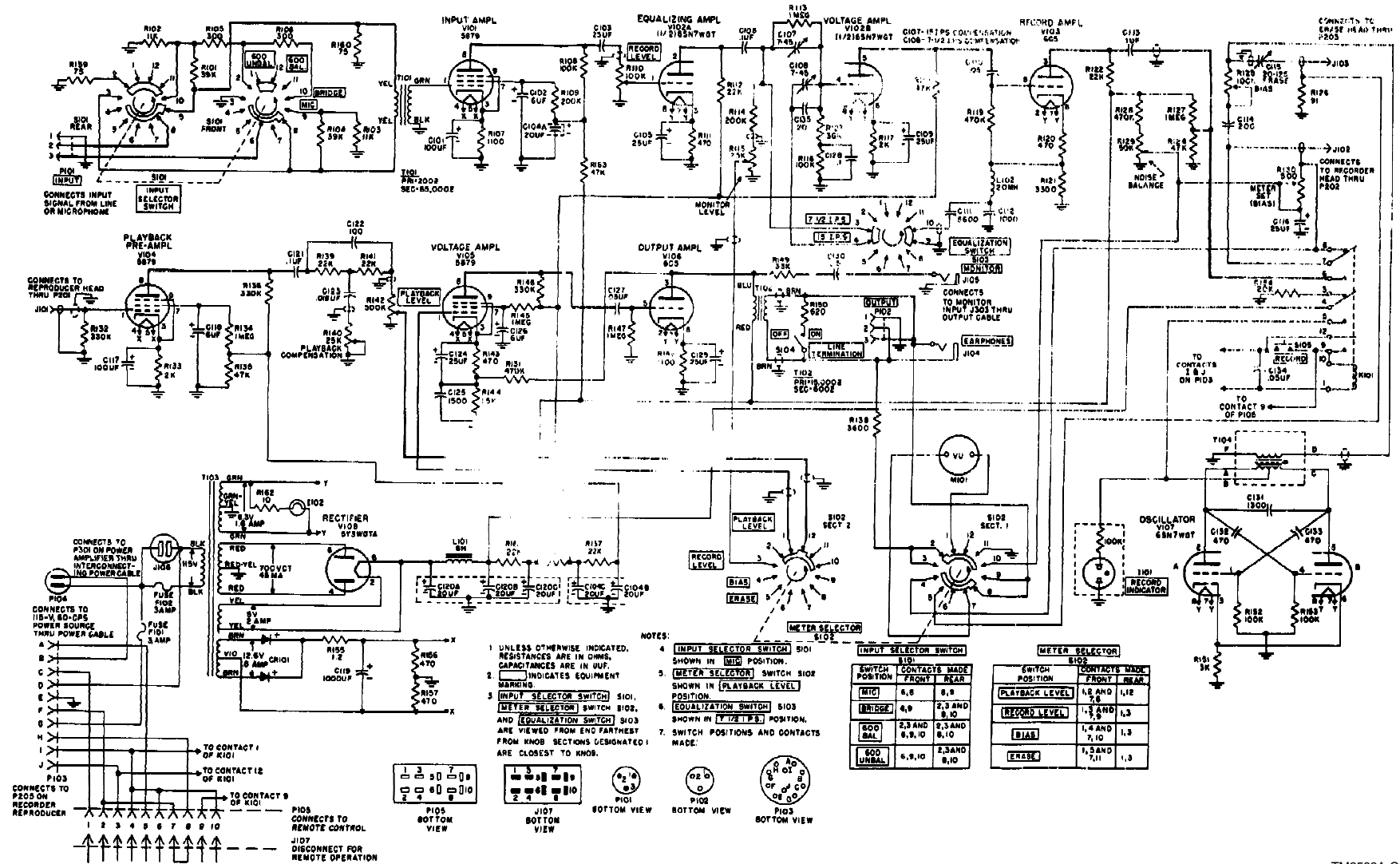

Figure 49.1. (Added) Amplifier (AM-1634/TNH-2B), schematic diagram.

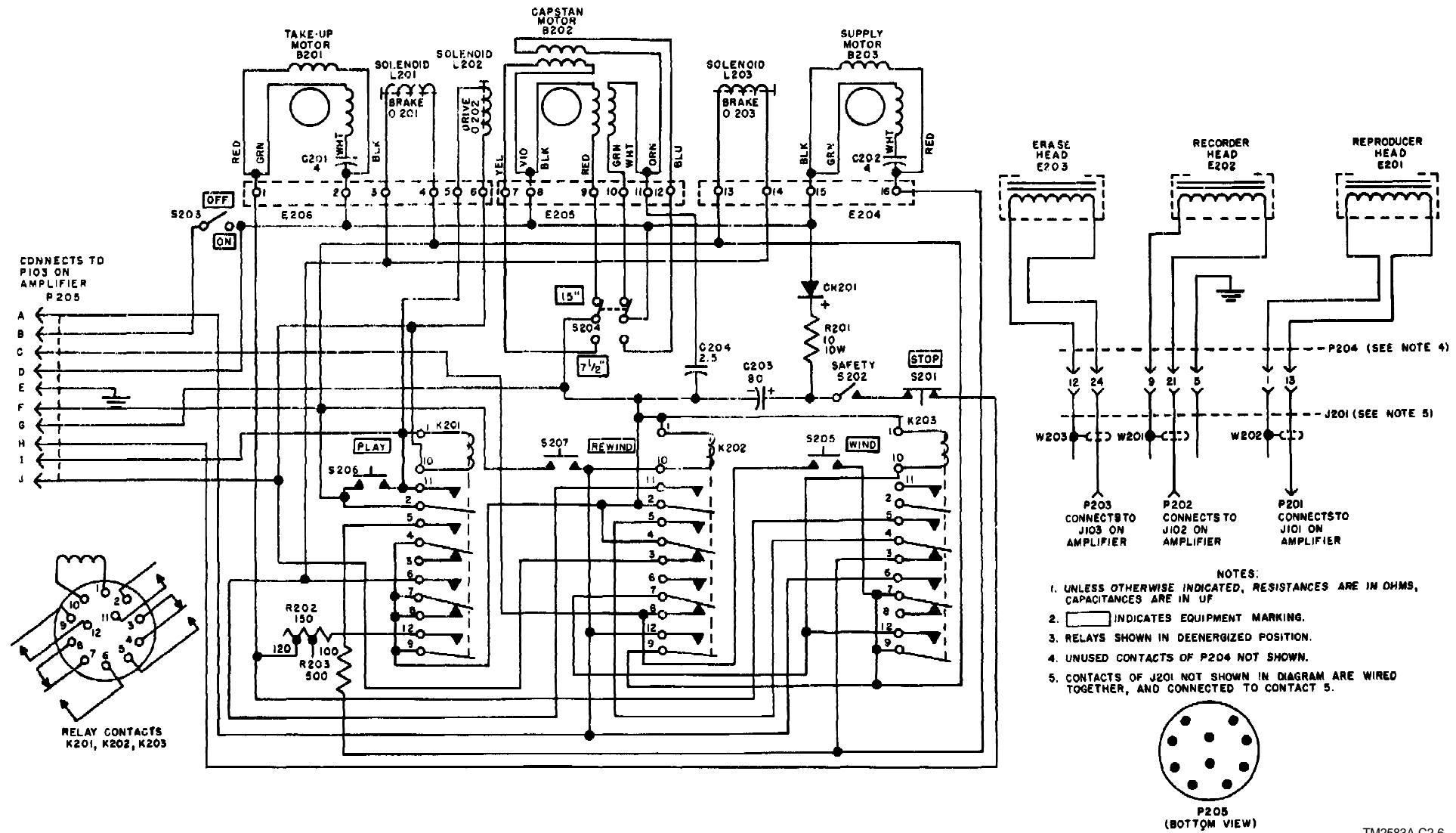
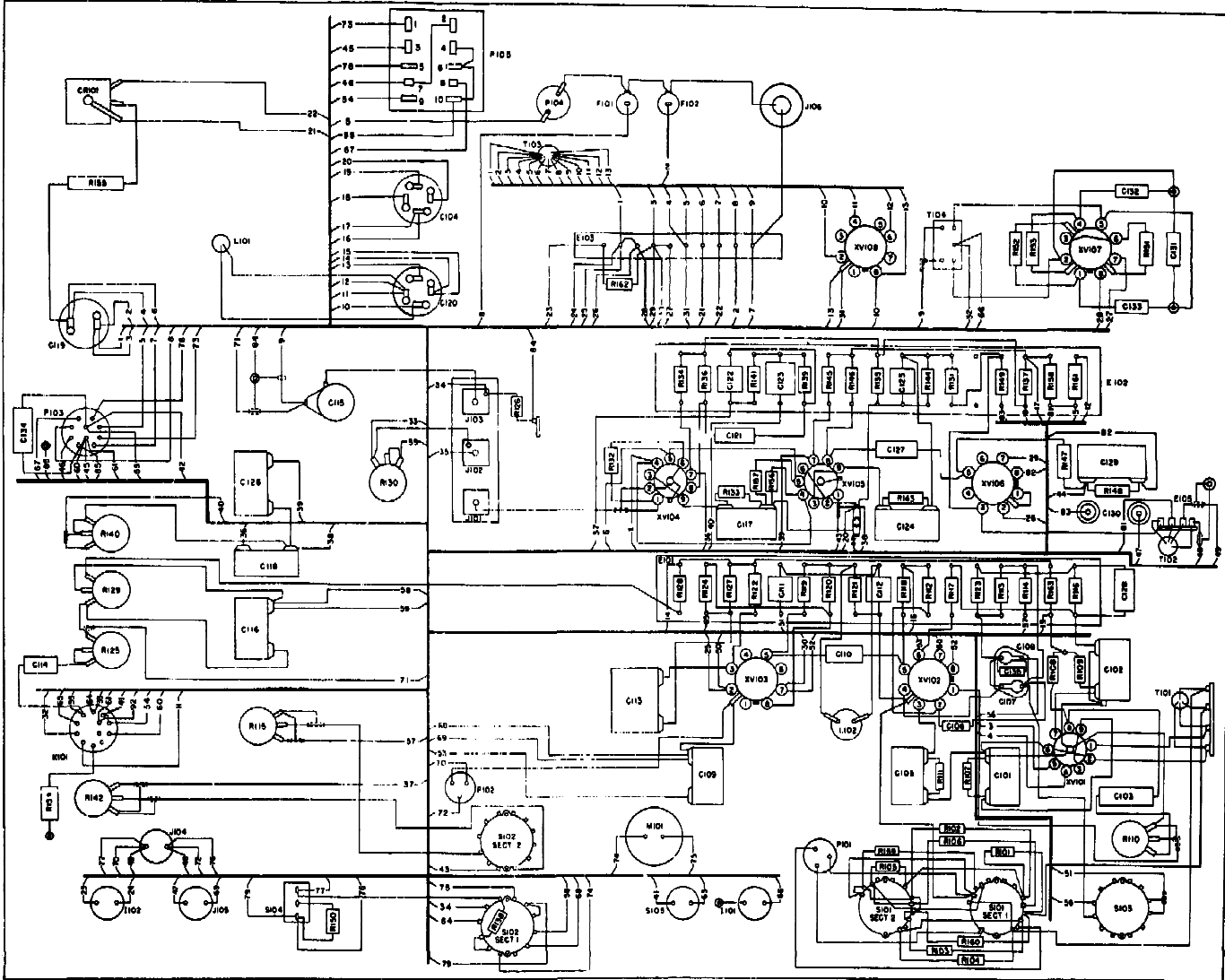
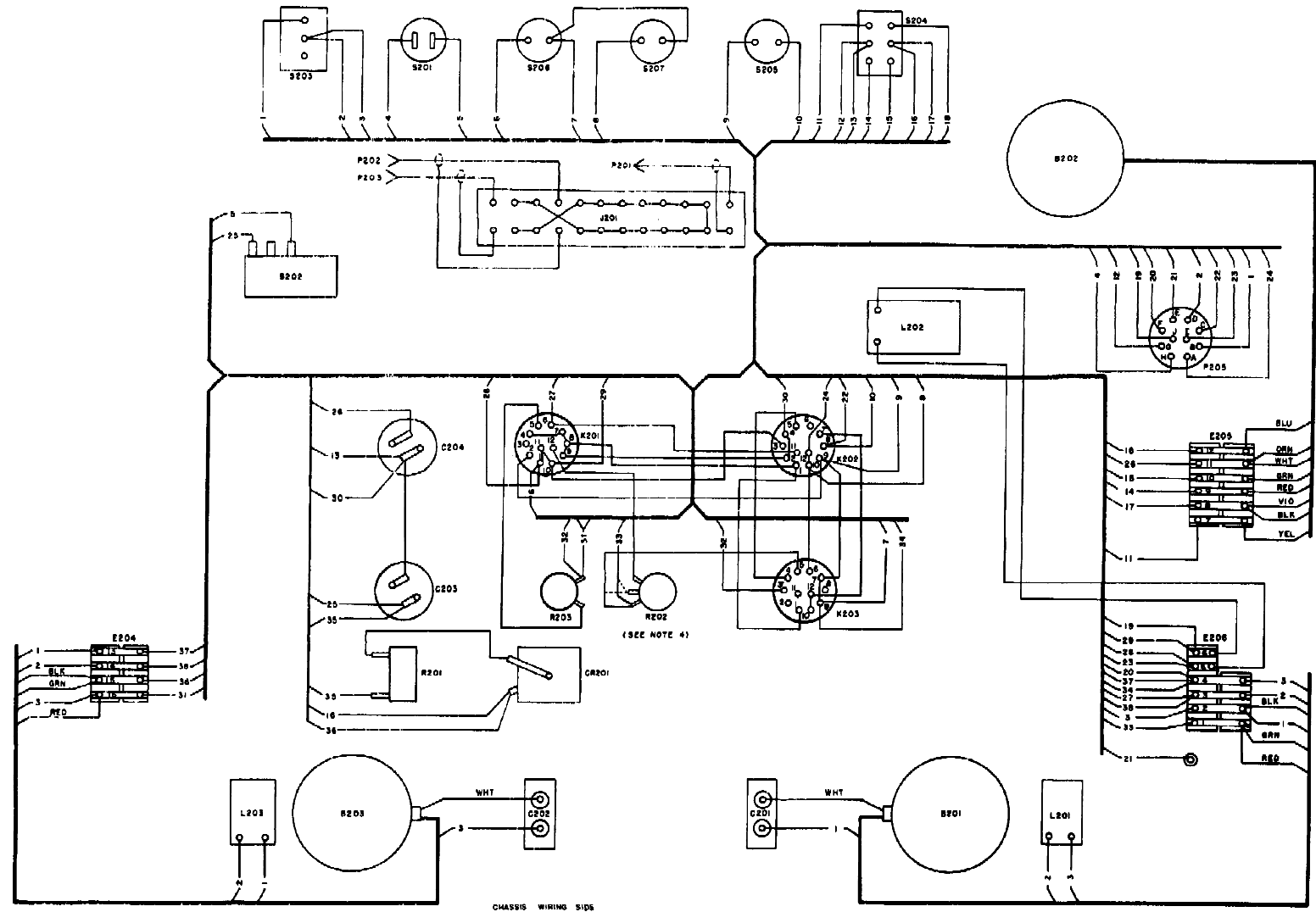

Figure 50.1. (Added) Recorder-reproducer (RD-149/TNH-2B), schematic diagram.



- NOTES:
1. THE WIRES OF EACH CABLE ARE NUMBERED CONSECUTIVELY. EACH GROUP OF NUMBERS STARTS WITH NO. 1.
  2. IN ANY ONE CABLE, THE TWO POINTS INDICATED BY WIRE NO. 1 ARE CONNECTED; THOSE IND. BY WIRE NO. 2 ARE CONNECTED; ETC.
  3. THE ANGLE AT WHICH A SPECIFIC WIRE ENTERS A CABLE INDICATES THE DIRECTION TO FOLLOW IN FINDING THE OTHER END.

Figure 52.1. (Added) Amplifier (AM-1634/TNH-2B), wiring diagram.



- NOTES:
1. THE WIRES OF EACH CABLE ARE NUMBERED CONSECUTIVELY, EACH GROUP OF NUMBERS STARTS WITH NO. 1.
  2. IN ANY ONE CABLE, THE TWO POINTS INDICATED BY WIRE NO. 1 ARE CONNECTED; THOSE TIED TO WIRE 2 ARE CONNECTED, ETC.
  3. THE ANGLE AT WHICH A SPECIFIC WIRE ENTERS A CABLE INDICATES THE DIRECTION TO FOLLOW IN FINDING THE OTHER END.
  4. BROKEN LINES INDICATE CONNECTIONS USED ON SOME EQUIPMENTS.

Figure 53.1. (Added) Recorder-reproducer, (RI) 148/TNH-2B, wiring diagram.

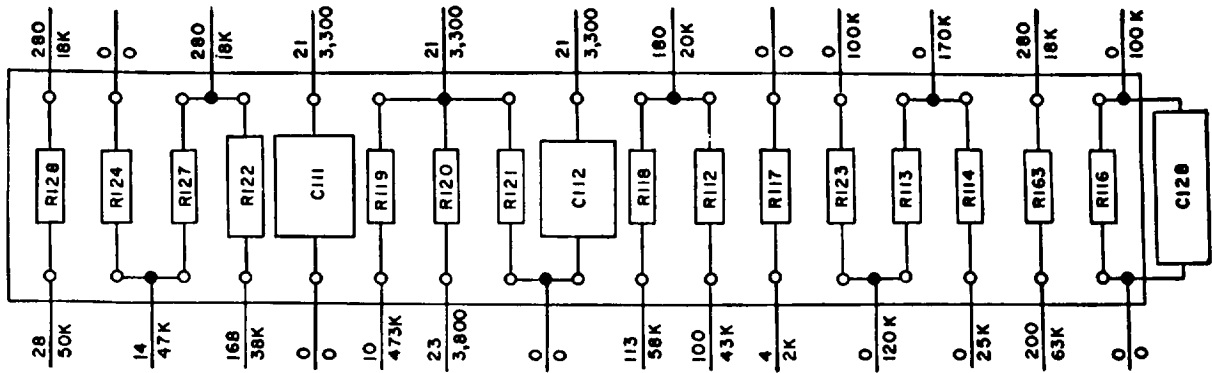

- NOTES:
1. ALL VOLTAGES ARE ABOVE THE LINE AND ARE DC.
  2. ALL RESISTANCES ARE BELOW THE LINE.
  3. ALL VOLTAGES MEASURED WITH MULTIMETER TS-352/U (20000 OHMS/VOLT), OR EQUAL.
  4. ALL RESISTANCES MEASURED TO GROUND WITH METER SELECTOR IN PLAYBACK LEVEL, AND RECORD LEVEL, AND PLAYBACK LEVEL CONTROLS OPERATED TO SETTING 10

TM2583A-C2-2

Figure 30.1. (Added) Amplifier chassis (AM-1634/TNH-2B), resistor-capacitor board (nearer to panel).

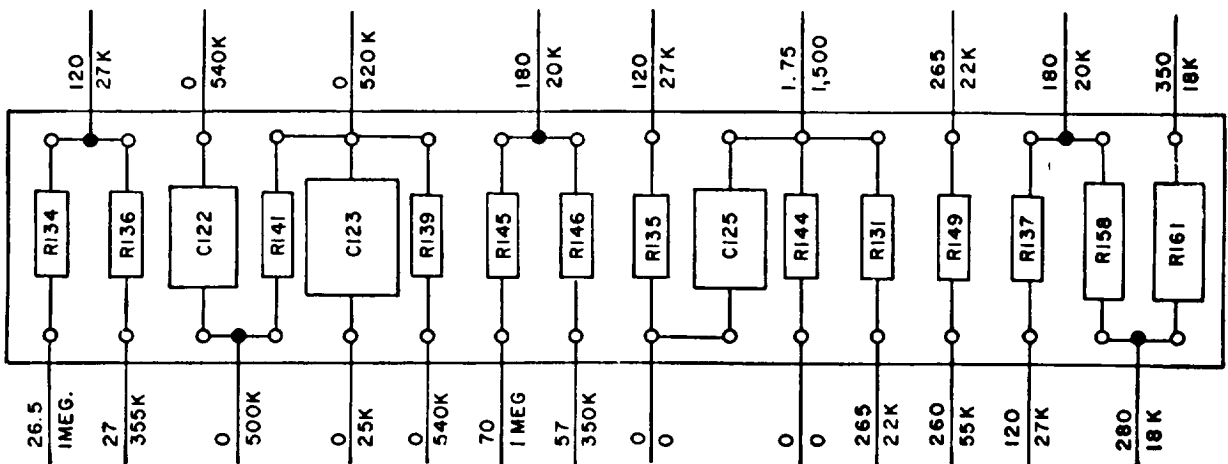

- NOTES:
1. ALL VOLTAGES ARE ABOVE THE LINE AND ARE DC.
  2. ALL RESISTANCES ARE BELOW THE LINE.
  3. ALL VOLTAGES MEASURED WITH MULTIMETER TS-352/U (20000 OHMS/VOLT), OR EQUAL.
  4. ALL RESISTANCES MEASURED TO GROUND WITH METER SELECTOR IN PLAYBACK LEVEL, AND RECORD LEVEL, AND PLAYBACK LEVEL CONTROLS OPERATED TO SETTING 10

TM2583A-C2-3

Figure 31.1. (Added) Amplifier chassis (AM-1634/TNH-2B), resistor-capacitor board (farther from panel).

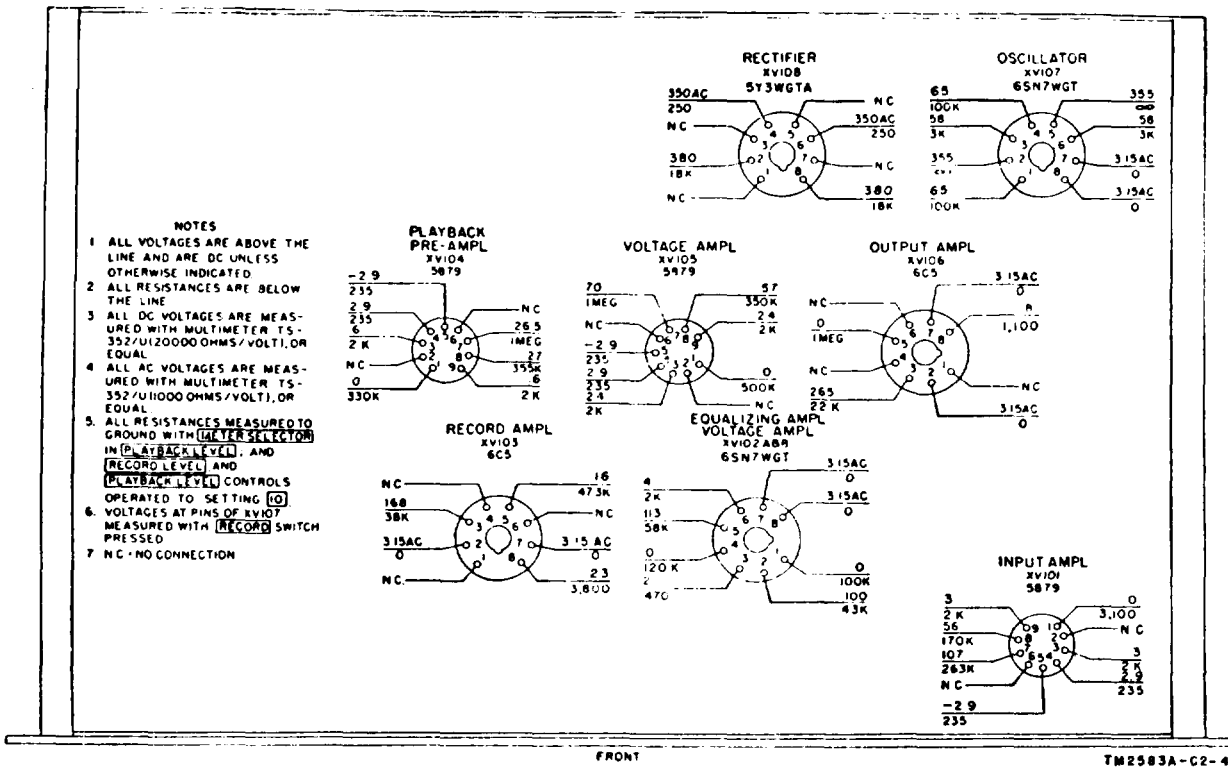

Figure 34.1. (Added) Voltage and resistance chart, amplifier (AM-1634/TNH-2B).



By Order of *Wilber M. Brucker*, Secretary of the Army:

MAXWELL D. TAYLOR,  
*General, United States Army,*  
*Chief of Staff.*

Official:

HERBERT M. JONES,  
*Major General, United States Army,*  
*The Adjutant General.*

Distribution:

*Active Army:*

CNGB	OS Sup Agencies
ASA	Army Elet PG
Tec Svc, DA	Sig Fld Maint Shops
Tec Svc Bd .	Sig Lab
Hq CONARC	ACS
CONARC Bd	Mil Dist
CONARC Bd Test Sec	Units org under fol TOE:
Army AA Cored	11-7C
OS Maj Cored	11-16C
OS Base Cored	11-57C
Log Cored	11-127R
MDW	11-128C
Armies	11-500R
Corps	11-557C
Div	11-587R
Ft & Cp	11-592R
Sp Wpn Cored	11-597R
Army Cml Cen	12-35R
Gen & Br Svc Sch	32-51R
Gen Depots	32-55R
Sig See, Gen Depots	32-56R
Sig Depots	32-57R
US Army Tng Cen	3367R
POE (OS)	33-77R
Trans Terminal Cored	45-500R (AA-AC)
Army Terminals	

*NG:* State AG; units—same as Active Army.

*USAR:* None.

For explanation of abbreviations used, see SR 320-50-1.



TECHNICAL MANUAL  
SOUND RECORDER-REPRODUCER SET AN/TNH-2A

TM 11-2583A }  
CHANGES No. 1 }

DEPARTMENT OF THE ARMY  
WASHINGTON 25, D. C., 9 March 1956

TM 11-2583A, 30 January 1956, is changed as follows:  
*Paragraph 5.* Add the following after "Tape reels":

Component	Required No.	Height (in.)	Depth (in.)	Width (in.)	Volume (cu ft)	Weight (lb)
Tape splicer . . . . .	1	1 ½	5 ¾	2 ¾	0.015	0.25
Splicing tape . . . . .	2	¾	3	3	.03	.05
Leader and timing tape . . . . .	1	¾	3	3	.015	.05

*Paragraph 6.* Make the following changes:

*f.* Add the following after the last sentence:  
Amplifier Case CY-1830/TNH-2A also contains splicing tape, leader and timing tape, and a tape splicer (fig. 4).

*m.* (Added) *Tape Splicer* (fig. 4). This is a manually operated device used to splice torn recording tape or to splice portions of the leader and timing tape to the recording tape.

*n.* (Added) *Splicing Tape* (fig. 4). This is an adhesive-type tape, ½ inch wide by 150 inches long, used to splice torn recording tape or to splice the leader and timing tape to the recording tape for editing purposes.

*o.* (Added) *Leader and Timing Tape* (fig. 4). This is a paper tape, ¼ inch by 150 inches long, marked with multicolored spots spaced 15 inches apart. The tape is spliced to the recording tape to indicate the beginning and end of the recorded data. The tape may be used to check the travel time (or speed) of the recording tape.

*Paragraph 13.* Add the following to *f*:

To identify the program to be recorded, splice a portion of the leader and timing tape (par. 22) to the free end of the recording tape and identify the program on the face of the leader and timing tape.

*Paragraph 14.* Make the following changes:

*j.* Add the following after the last sentence:  
Use the leader and timing tape to identify each reel of tape (par. 13f).

*l.* Add the following after the last sentence:  
Use the leader and timing tape to identify

each set of intelligence. Splice the leader and timing tape to the recording tape (par. 22). Use a sufficient length of leader and timing tape to provide a suitable dead space. Identify each set of intelligence by marking the face of the leader and timing tape with the appropriate information.

*Paragraph 15f.* Add the following: Use the leader and timing tape to identify each telephone conversation (par. 14i).

*Paragraph 22.*

**22. Splicing Tape**

(Superseded) (fig. 11.1)

Splice the recording tape as follows:

*a.* Place the two loose ends of the torn tape in the tape guides with the glossy side of the tape up; be sure to overlap the ends at least ¼ inch.

*b.* Lower the tape fingers.

*c.* Push the knob of the splicer back to the miter position, and press the lever down (A, fig. 11.1).

*d.* Raise the lever.

*e.* Blow away the small pieces of tape that have been cut from the tape.

*f.* Apply a small strip of splicing tape over the cut ends of the recording tape (B, fig. 11.1).

*g.* Move the knob of the splicer to the trim position and press the lever down. Trimmed splicing tape should be slightly narrower than the recording tape (C, fig. 11.1).

*h.* Remove the tape from the splicer.

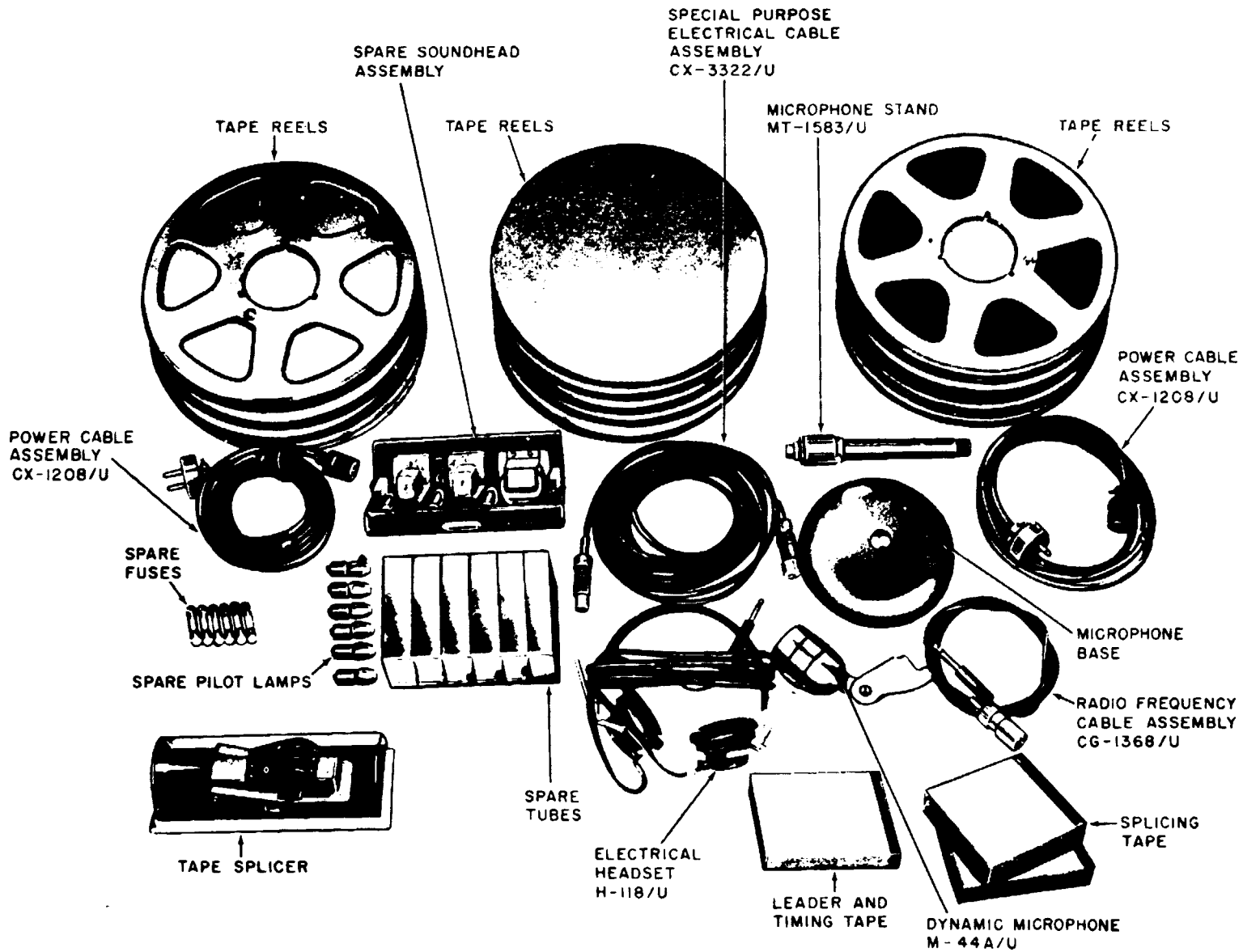

TAGO 5578A

TM 2583A-CI-1

Figure 4. (Superseded) Accessories, running spares, and now components of Sound Recorder-Reproducer Set AN/TNH-2A.

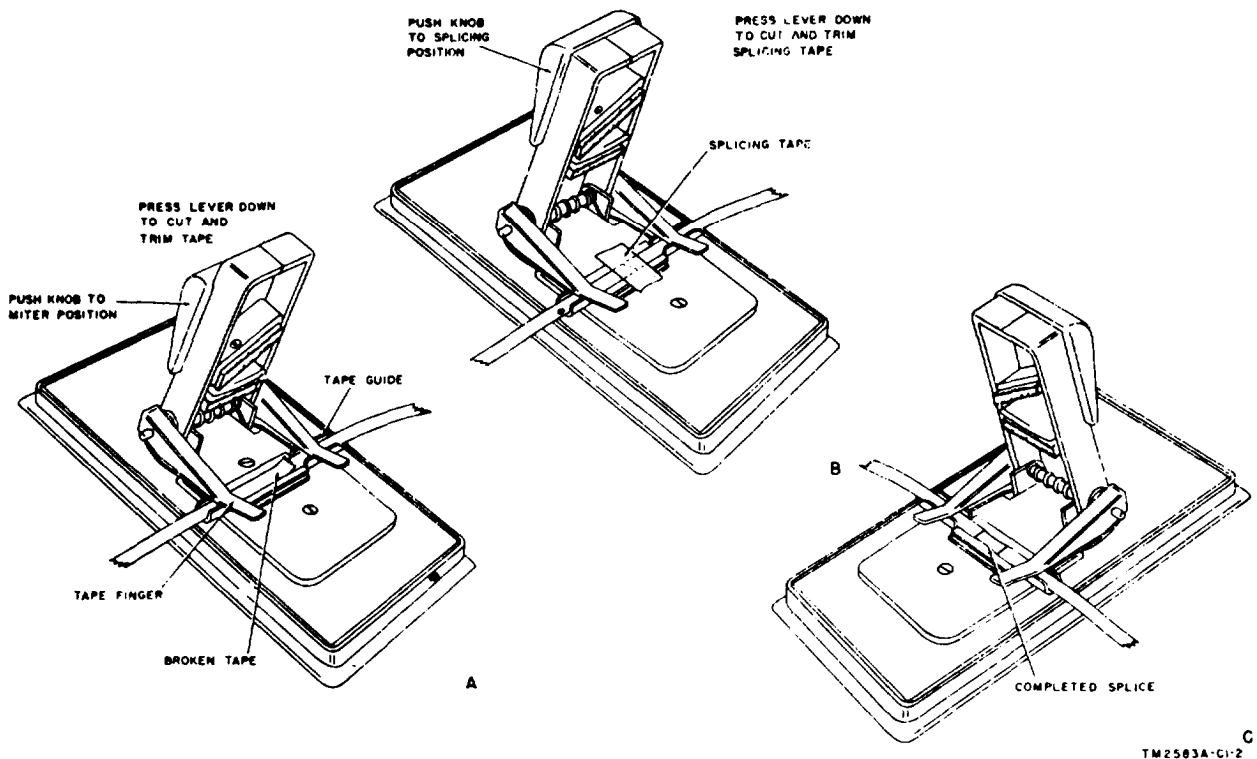

Figure 11.1. (Added) Splicing tape.

### 35. Lubrication

(Superseded) (fig. 17.1 )

a. *General.* Under severe salt-air conditions, apply a small quantity of Cleaning Compound to the contacts of the INPUT SELECTOR SWITCH, METER SELECTOR switch, and EQUALIZATION switch (fig. 12) of the amplifier, and the function switch of the audio amplifier (fig. 13 ) to remove corrosion. Remove the Cleaning Compound residue and apply a very small quantity of petrolatum (PET) to the contacts. Only a very light coating of petrolatum is required once annually under severe salt-air conditions.

b. *Capstan Motor (fig. 17.1).* Once every 1,000 hours of operation, lubricate the capstan motor as follows:

- (1) Remove the four 10-32 screws that secure the louver to the front of the recorder-reproducer and remove the louver. The capstan motor is now exposed.
- (2) Lift the oil filler cap, apply 2 drops of oil (OAI) to the bearing and close the oil filler cap.
- (3) Examine the chassis for drops of oil and remove oil if required.
- (4) Replace the louver.

### 90.1 Timing

(Added)

To check the tape-travel time of the recorder-reproducer, proceed as follows:

- a. Prepare the equipment for 7½ ips operation (par. 14).
- b. Install and thread the leader and timing tape.
- c. Turn on the equipment and allow at least a 5-minute warmup time.
- d. Press the PLAY and RECORD switches.
- e. Check the timing, using an accurate stop watch, by counting the number of colored patches on the tape entering the soundhead assembly. One hundred patches should enter the soundhead in 3 minutes and 20 seconds.
- f. If timing is incorrect by more than ½ of 1 percent, check the power frequency and the pressure roller adjustment (par. 78).
- g. If timing is still incorrect, replace the capstan motor (par. 73).
- h. Move the 7½"-15" switch to the 15" position and check the timing at 15 ips. One hundred patches should enter the soundhead in 1 minute and 40 seconds.
- i. If timing is incorrect, repeat procedure in f and g above.

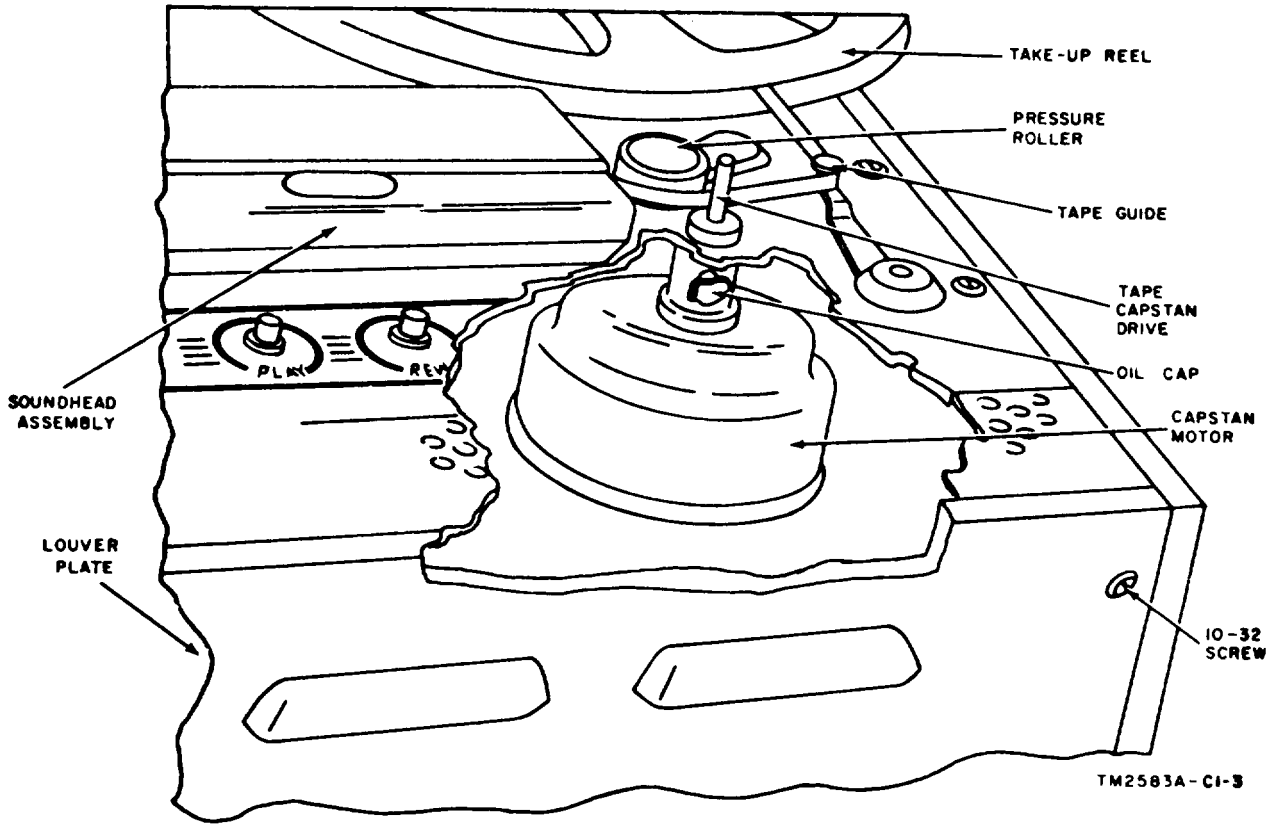

Figure 17.1 (Added) Capstan motor, location oil filler cap.

[AG 413.44 (7 Mar 56) ]

*By Order of Wilber M. Brucker, Secretary of the Army:*

**MAXWELL D. TAYLOR**  
*General, United States Army,  
Chief of Staff.*

Official:

**JOHN A. KLEIN,**  
*Major General, United States, Army,  
The Adjutant General*

**DISTRIBUTION:**

*Active Army:*

CNGB (1)	Sig Depots (20)	11587R, Sig Base Maint Co (2)
Tee Svc, DA (1) except CSIGO (30)	Trans Terminal Cond (2)	11-592R, Hq & Hq Co, Sig Base
Tee Svc Bd (1)	Army Terminals (2)	Depot (2)
Hq CONARC (5)	OS Sup Agencies (2)	11-597R, Sig Base Depot Co (2)
CONARC Bd(Incl ea Test Sec (1)	Sig Fld Maint Shops(3)	12-35R, Sp Band (2)
Army AA Comd (2)	Sig Lab (5)	12- 107-C. Org or Sep Band (2)
OS Maj Comd (5)	Mil Dist (1)	17R, Armd Div (2)
OS Base Comd (5)	Units organized under following	32-51R, Hq & Hq Co, Comm
Log Comd (5)	TOE's:	Recon Gp (U) (2)
MDW (1)	7R. Inf Div (2)	32-55R, Comm Recin Bn (U) (2)
Armies (5)	11-7R, Sig Co, Inf Div (2)	32-56R, Hq & Hq Co, Comm
Corps (2)	11-16R, Hq & Hq Co, Sig Bn,	Recon Bn (U) (2)
Tng Div (2)	Corps or Abn Corps (2)	32-57R, Comm Recon Opr Co
Ft & Cp (2)	11-57R, Armd Sig, Co (2)	(U) (2)
Gen & Br Svc Sch (5) except Sig	11-127R, Sig Rep Co (2)	32-500R (AA-AG), Comm Re-
Sch (25)	11-128R, Sig Depot Co (2)	con) or (U) (2)
Gen Depots (2) except Atlanta Gen	11-500R (AA-AE), Sig Svc Org	33-77R Loudspeaker and Leaflet
Depot (None)	(2)	Co Army (2)
Sig Sec, Gen Depots (10)	11-557C. Abn Sig Co (2)	

NG: State AG (6); units- same as Active Army except allowance is one copy per unit.

USAR: None.

For explanation of abbreviations used, see SR 320-50-1.





## SOUND RECORDER-REPRODUCER SET AN/TNH-2A

---

	<i>Paragraph</i>	<i>Page</i>
<b>CHAPTER 1. INTRODUCTION</b>		
Section I. General .....	1, 2	1
II. Description and data .....	3-7	1
<b>CHAPTER 2. INSTALLATION</b> .....	8-12	7
<b>CHAPTER 3. OPERATION</b>		
Section I. Operation under usual conditions .....	13-23	13
II. Operation under unusual conditions .....	24-27	21
<b>CHAPTER 4. ORGANIZATIONAL MAINTENANCE</b>		
Section I. Controls and instruments, .....	28, 29	23
II. Organizational tools and equipment .....	30, 31	24
III. Preventive maintenance services .....	32-34	25
IV. Lubrication and weatherproofing .....	35-37	29
V. Trouble shooting at organizational maintenance level .....	36-43	31
<b>CHAPTER 5. THEORY</b> .....	44-68	37
<b>CHAPTER 6. FIELD MAINTENANCE</b>		
Section I. Trouble shooting at field maintenance level .....	59-69	48
II. Repairs .....	70-74	66
III. Mechanical adjustments .....	75-78	70
IV. Final testing .....	79-94	71
<b>CHAPTER 7. SHIPMENT AND LIMITED STORAGE AND DEMOLITION TO     PREVENT ENEMY USE</b> .....	95-98	82
<b>INDEX</b> .....		85

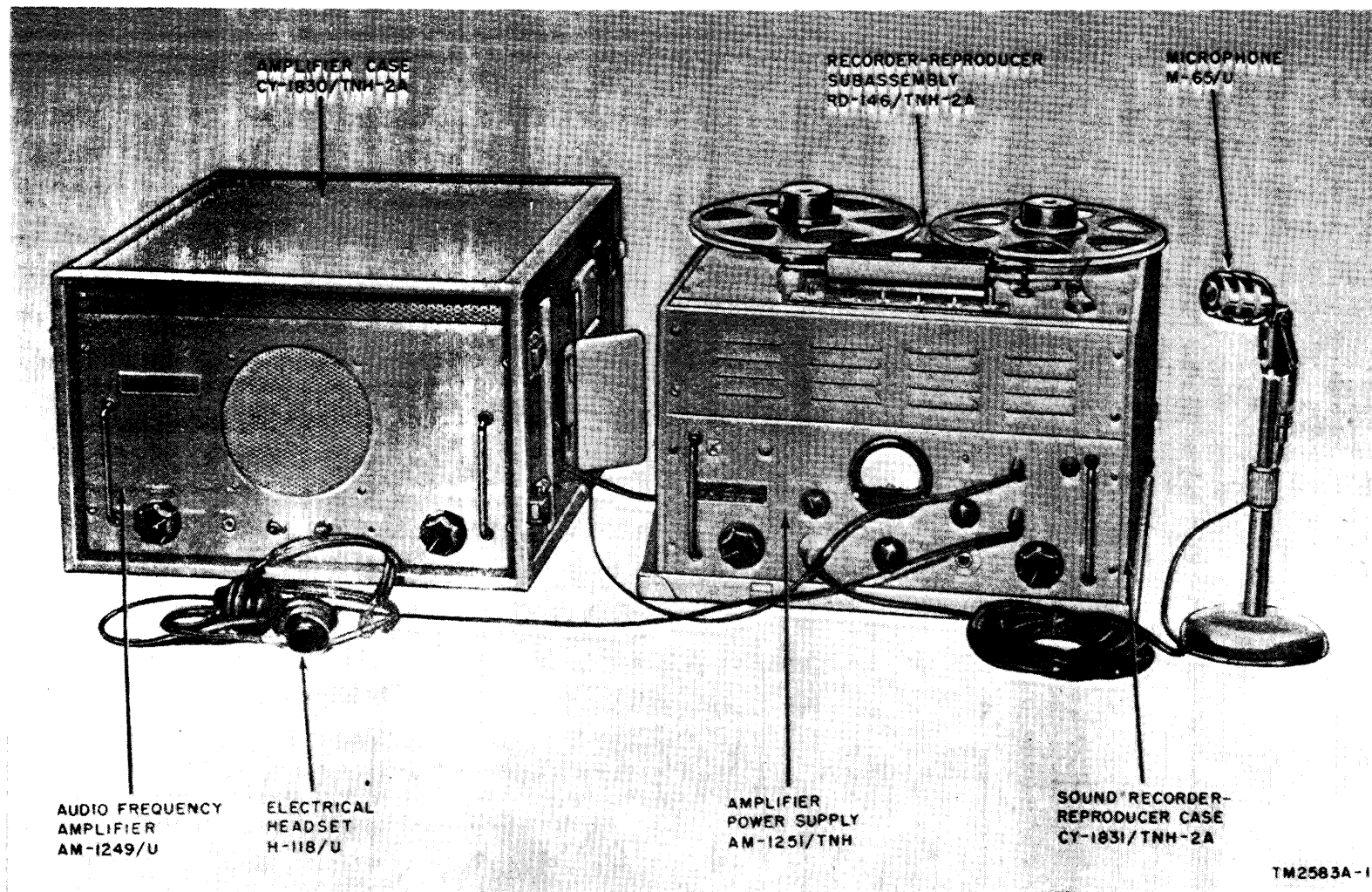

Figure 1. Sound Recorder-Reproducer Set AN/TNH-2A, set up for operation

## CHAPTER 1

### INTRODUCTION

---

#### Section I. GENERAL

##### 1. Scope

*a.* This manual contains information on the operation, theory and maintenance of Sound Recorder-Reproducer Set AN/TNH-2A (fig. 1).

*b.* Forward comments on this publication directly to Commanding officer, The Signal Corps Publications Agency, Fort Monmouth, New Jersey.

##### 2. Forms and Records

###### *a. Unsatisfactory Equipment Reports.*

- (1) DA Form 468, Unsatisfactory Equipment Report, will be filled out and forwarded to the Office of the Chief Signal Officer as prescribed in SR 700-45-5.
- (2) DD Form 535, Unsatisfactory Report, will be filled out and forwarded to Commanding General, Air Materiel

Command, Wright-Patterson Air Force Base, Dayton, Ohio, as prescribed in SR 700-45-5 and AF TO 00-35D-54.

*b. Damaged or Improper Shipment.* DD Form 6, Report of Damaged or Improper Shipment, will be filled out and forwarded as prescribed in SR 745-45-5 (Army) ; Navy Shipping Guide, Article 1850-4 (Navy) ; and AFR 71-4 (Air Force).

###### *c. Preventive Maintenance Forms.*

- (1) DA Form 11-250, Operator First Echelon Maintenance Check List for Signal Corps Equipment, will be prepared in accordance with instructions on the back of the form (fig. 14).
- (2) DA Form 11-251, Second and Third Echelon Maintenance Check List for Signal Corps Equipment, will be prepared in accordance with instructions on the back of the form (fig. 15).

#### Section II. DESCRIPTION AND DATA

##### 3. Purpose and Use

Sound Recorder-Reproducer Set AN/TNH-2A (fig. 1) is a self-contained portable electro-mechanical half-track magnetic tape recorder and reproducer for making and reproducing sound recordings. The sound is recorded on and reproduced from a 2,400-foot magnetic tape moving at a rate of either 7 ½ inches per second (ips) or 15 ips.

*a. Recorder.* The equipment records speech or music from a microphone, telephone line, or program line source (par. 14, 15, and 16).

*b. Reproducer.* Recordings may be reproduced (played back) immediately after rewinding (while recording) or simultaneously while recording through the self-contained loudspeaker or the headset (par. 18), or an external 600-ohm program line, or an external loudspeaker (par. 21).

*c. Public Address.* The recorder-reproducer set may be used also as a public address set (par. 21) to cover a limited area with the self-contained loudspeaker in Audio Frequency Amplifier AM-1249/U, or a large area with suitable external loudspeaker (not supplied).

#### 4. Technical Characteristics

Power source requirement. . . . 115 v ac, 60 cps, single phase.

Power consumption:

Recorder- Reproducer Sub-assembly RD-146/TNH-2A and Amplifier-Power supply AM-1251/TNH . . . 250 w.

Audio Frequency Amplifier AM-1249/U . . . . . 60 w.

Audio power output . . . . . 8 w.

Frequency range:

Tape speed 15 ips . . . . . 50 to 10,000 cps  $\pm$ 2 db.

Tape speed 7½ ids . . . . . 50 to 7,000 cps  $\pm$ 2 db.

Input impedance:

Microphone . . . . . 150 ohms.

Bridge . . . . . 20,000 hms

Line, balanced or unbalanced 600 ohms.

Number of tubes:

Amplifier-Power Supply AM-1251/TNH . . . . . 8.

Audio Frequency Amplifier AM-1249/U . . . . . 5.

Recording-reproducing medium:

Type . . . . . Magnetic tape, dual track.

Tape size . . . . . ¼ in. wide, 2,400 ft long.

Playing time . . . . . 1 hour, single track at 7 ½ ips; 2 hours, both tracks at 7 ½ ips; ½ hour, single track

at 15 ips; 1 hour, both tracks at 15 ips.

Fast winding time . . . . . 1 minute.

Fast rewinding time . . . . . 1 minute.

Headset . . . . . 600-ohm impedance.

Microphone . . . . . Low impedance, dynamic type.

Output impedance:

Line . . . . . 600 ohms, balanced.

Monitor jack . . . . . 50,000 ohms.

Loudspeaker . . . . . 8 ohms.

Headset:

Amplifier-Power Supply AM-1251/TNH . . . . . 600 ohms

Audio Frequency Amplifier AM-1249/U . . . . . 8 ohms.

Loudspeaker (internal) :

Type . . . . . 8 in., dynamic, permanent magnetic type.

Voice coil impedance . . . . . 6 to 8 ohms.

Power rating . . . . . 8 w.

Oscillator frequency . . . . . 65 kc.

Flutter . . . . . Less than .2 per cent root mean square (rms) at 15 ips.

Wow . . . . . Less than .25 per cent rms at 15 ips.

Distortion . . . . . Less than 3 percent rms at 8 watts output.

#### 5. Table of Components (fig. 1 through 4)

The following table lists the components of Sound Recorder-Reproducer Set AN/TNH-2A.

Component	Required No.	Height (in.)	Depth (in.)	Width (in.)	Volume (cu ft)	Weight (lb)
Amplifier-Power Supply AM-1251/TNH	1	7	14	19	1.1	25
Recorder-Reproducer Subassembly RD-146/TNH-2A	1	6 ½	15¾	19	1.2	39
Audio Frequency Amplifier AM-1249/U	1	10 ½	7	19	.8	19
Sound Recorder-Reproducer Case CY-1831/TNH-2A	1	16½	21	21	4.2	36
Amplifier Case CY-1830/TNH-2A	1	14	24 ¼	21 ½	4.4	41
Dynamic Microphone M-65/U, consisting of:	1	14	6			
Dynamic Microphone M-44A/U	1	4½	2			
Microphone Stand MT-1583/U	1	8	6			
Electrical Headset H-118/U	1					
Radio Frequency Cable Assembly CG-1368/U	1			72		
Power Cable Assembly CX-1208/U (6 ft 0 in.)	2			72		
Special Purpose Electrical Cable Assembly CX-3322/U (20 ft 0 in.)	1			240		

Component	Required No.	Height (in.)	Depth (in.)	Width (in.)	Volume (Cu ft)	Weight (lb)
Tape Reels	16 (15 w/tape, 1 empty)	5/8		10½ dia	.04	
Running spares consisting of:						
Tubes:						
12AX7	1					
5879	1					
6V6	1					
5Y3GT	1					
6SN7GT	1					
6C5	1					
Fuses: 3 amp	6					
Pilot (lamps)	6					
Cables:						
CX-1208/U	1		72			
CG-1368/U	1		72			
Soundhead assembly	1					

## 6. Description of Equipment

a. *General.* Sound Recorder-Reproducer Set AN/TNH-2A consists of Amplifier-Power Supply AM-1251/TNH and Recorder-Reproducer Subassembly RD-146/TNH-2A contained in Sound Recorder-Reproducer Case CY-1831/TNH-2A, and Audio Frequency Amplifier AM-1249/U, Dynamic Microphone M-65/U, Electrical Headset H-118/U, connecting cables, and running spares contained in Amplifier Case CY-1830/TNH-2A.

b. *Amplifier-Power Supply AM-1251/TNH* (fig. 1). This unit contains the recording amplifier, the reproducer amplifier, the bias erase-oscillator, and a power supply. The front panel mounts the controls for operating these circuits, as well as a record level indicator, a volume unit (vu) meter, and the necessary connectors and jacks for interconnecting the components. The rear panel of this unit mounts the fuses and connectors for alternating current (ac) input power. The rear panel is accessible after opening the access door at the rear of Sound Recorder-Reproducer Case CY-1831/TNH-2A.

c. *Recorder-Reproducer Subassembly RD-146/TNH-2A* (fig. 1). This subassembly is an electromechanical unit which contains the tape-transport mechanism, the sound head assembly, and the operating controls mounted on the front panel. The under portion of the panel mounts the motors, the electronic components, and the connectors for power and signals.

d. *Sound Recorder-Reproducer Case CY-*

*1831/TNH-2A* (fig. 2). This case is a gray, aluminum-clad, plywood case containing Recorder-Reproducer Subassembly RD-146/TNH-2A and Amplifier-Power Supply AM-1251/TNH. A door on the rear of the case provides access to the input power connector and fuses.

e. *Audio Frequency Amplifier AM-1249/U* (fig. 1). This unit contains a power amplifier and a power supply circuit. The front panel mounts the loudspeaker, a level control, a selector switch, a pilot light, fuse, and the necessary output jacks. The rear panel of the unit mounts the power connector and signal input connector. The rear panel is accessible after opening the access door at the side of Amplifier Case CY-1830/TNH-2A.

f. *Amplifier Case CY-1830/TNH-2A* (fig. 3). This case is an aluminum-clad, plywood case containing Audio Frequency Amplifier AM-1249/U, Dynamic Microphone M-65/U, Electrical Headset H-118/U, Power Cable Assembly CX-1208/U, the interconnecting cables, a spare sound head assembly, running spares, 15 reels of tape, one empty reel, and spare cables are stored within the case.

g. *Dynamic Microphone M-65/U* (fig. 1). The microphone is a low-impedance directional-type microphone with a connector. The microphone consists of Dynamic Microphone M-44A/U and Microphone Stand MT-1583/U.

h. *Electrical Headset H-118/U* (fig. 4). The headset is a high-fidelity, dynamic-type, 600-ohm headset with a 5-foot connecting cord terminated with a telephone plug.

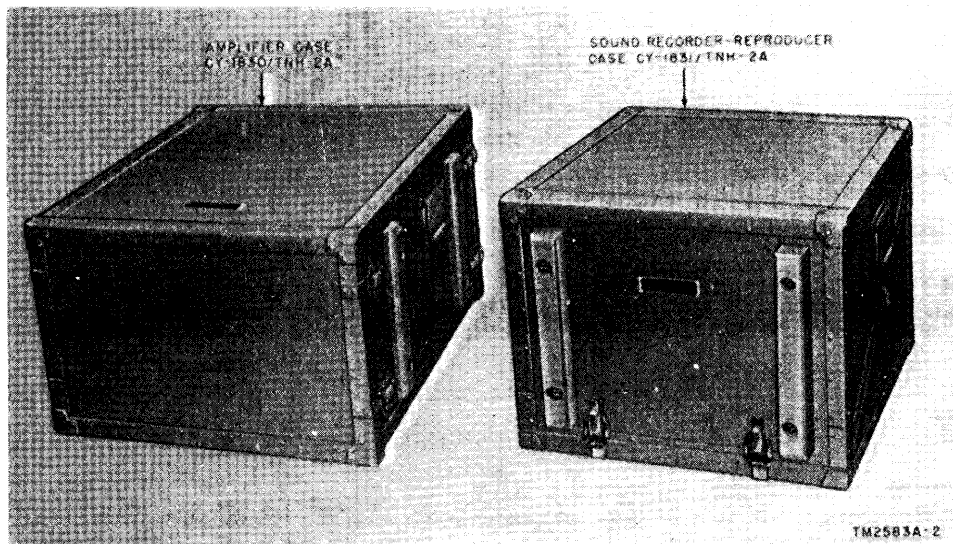

Figure 2. Sound Recorder-Reproducer Set AN/TNH-2A, carrying case.

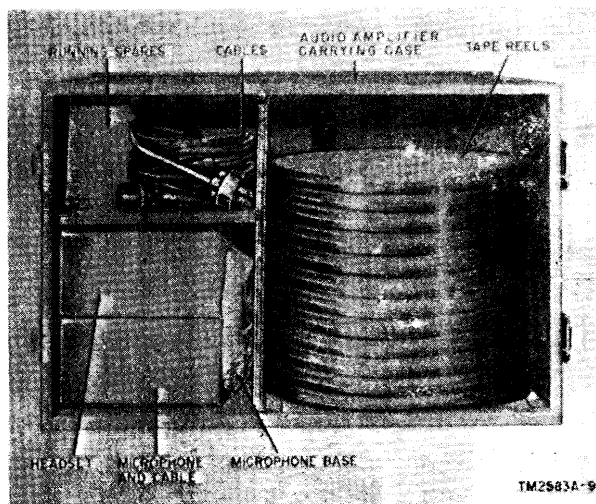

Figure 3. Amplifier Case CY-1830/TNH-2A, cover removed, rear view, showing location of stowed material.

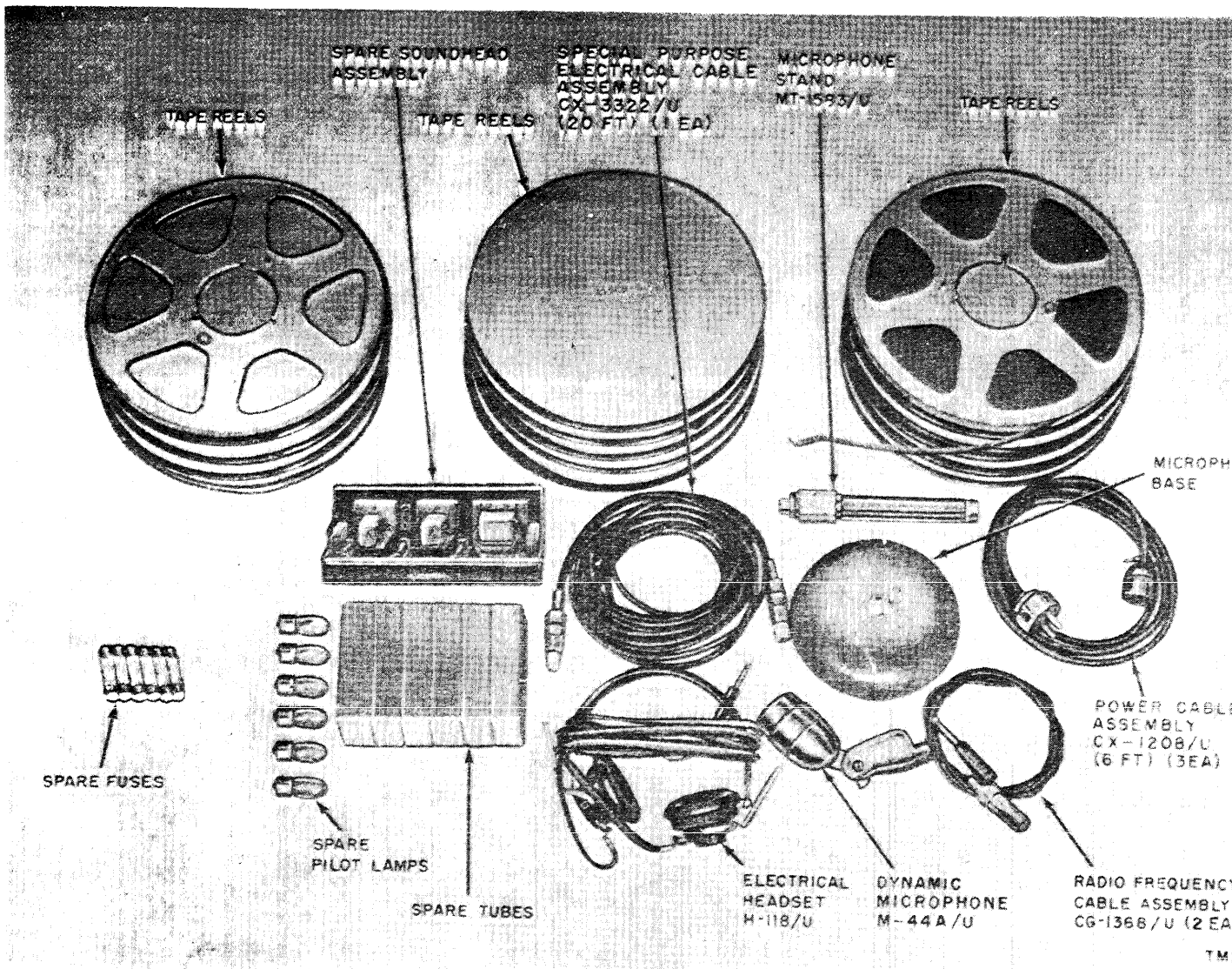

Figure 4. Sound Recorder-Reproducer Set AN/TNH-2A, accessories, running spares, and some components.

i. *Power Cable Assembly CX-1208/U (6 ft 0 in.)* (fig. 4). This cable assembly is a conductor, rubber-covered, 6-foot cable, one end of which is terminated with a female connector and the other end is terminated with a male connector.

j. *Radio Frequency Cable Assembly CG-1368/U* (fig. 4). This 6-foot, shielded, single-conductor, rubber-covered coaxial cable is terminated at one end in a female connector and at the other end in a telephone-type plug (PL-55).

k. *Special Purpose Electrical Cable Assembly CX-3822/U (20 ft 0 in.)* (fig. 4). This 20-foot two-conductor, shielded, rubber-covered cable is terminated on one end with a female connector and at the other end with a recessed male connector.

### 7. Nomenclature Versus Common Names

The following chart lists nomenclatures and their respective common names used in this manual.

Nomenclature	Common name
Sound Recorder-Reproducer Set AN/TNH-2A	Recorder-reproducer set
Recorder-Reproducer Subassembly -RD-1461/TNH/2A	Recorder-reproducer
Amplifier-Power Supply AM-1251/TNH	Amplifier
Audio Frequency Amplifier AM-1249/U	Audio amplifier
Amplifier Case CY-1830/TNH-2A	Audio amplifier carrying case
Sound Recorder-Reproducer Case CY-1831/TNH-2A	Recorder-reproducer carrying case
Dynamic Microphone M-65/U	Microphone
Electrical Headset H-118/U	Headset
Power Cable Assembly CX-1208/U (6 ft)	Interconnecting power cable
Special purpose Electrical Cable Assembly CX-3322/U (20 ft)	Microphone cable
Radio Frequency Cable Assembly CG-1368/U	Output cable
Power Cable Assembly CX-1208/U (6 ft)	Power cable



## CHAPTER 2

### INSTALLATION

#### 8. Packaging Data

(fig. 5)

When packaged for export shipment, the equipment in the carrying cases is placed in moistureproof containers and packed in two wooden boxes. The following chart lists the contents and dimensions of each box.

Box No.	Dimension (in. )			Volume (cuft)	Weight (lb)
	Height	Width	Depth		
1	23	27	27	9.4	140
2	20	31	27	10	150

#### 9. Unpacking and Checking

(fig. 5)

*a. General.* When unpacking the equipment, be careful not to damage the carrying case by thrusting tools into the interior. Follow the directions given below.

*b. Unpacking.*

- (1) Place the wooden packing case close to the operating site.
- (2) Cut and fold back the metal straps.
- (3) Remove the nails with a nail puller. Remove the wooden cover and one side of the wooden packing case.
- (4) Slit the moistureproof barrier, and lift out the outer corrugated carton.
- (5) Open the outer corrugated carton by cutting the sealing tape. Do not damage the carton.
- (6) Slit the moisture-vaporproof barrier, and lift out the inner corrugated carton.
- (7) Open the inner corrugated carton by cutting the tape that seals it. Remove the desiccant, and lift the carrying case out of the carton.

(8) Open the carrying cases by unfastening the latches. Check the contents against the packing slip.

(9) Inspect the equipment thoroughly for shipping damage.

#### 10. Installation of Equipment

*a. General.* The recorder-reproducer set is packaged with all tubes and fuses in place, and with one end of the interconnecting power cable connected to the amplifier. The recorder-reproducer set may be rack-mounted (fig. 6) or it may be installed as a desk or table unit with the components in their respective carrying cases (fig. 1) (with the carrying cases stacked or separated). Allow enough room for operating the equipment.

*b. Setting up Equipment in Carrying Cases.*

- (1) Unlatch and remove the covers of both carrying cases.
- (2) Move the ON-OFF switch (fig. 7) on the recorder-reproducer to the OFF position.
- (3) Turn the RECORD LEVEL control (fig. 12) of the amplifier to the 0 position.
- (4) Turn the INPUT SELECTOR SWITCH of the amplifier to the MIC. position.
- (5) Turn the METER SELECTOR control of the amplifier to the RECORD LEVEL position.
- (6) Connect the microphone cable to the INPUT connector (fig. 8) of the amplifier by lining up the key on the microphone cable connector with the keyway on the INPUT connector, and pushing the connector.
- (7) Open the access door at the back of the recorder-reproducer carrying case

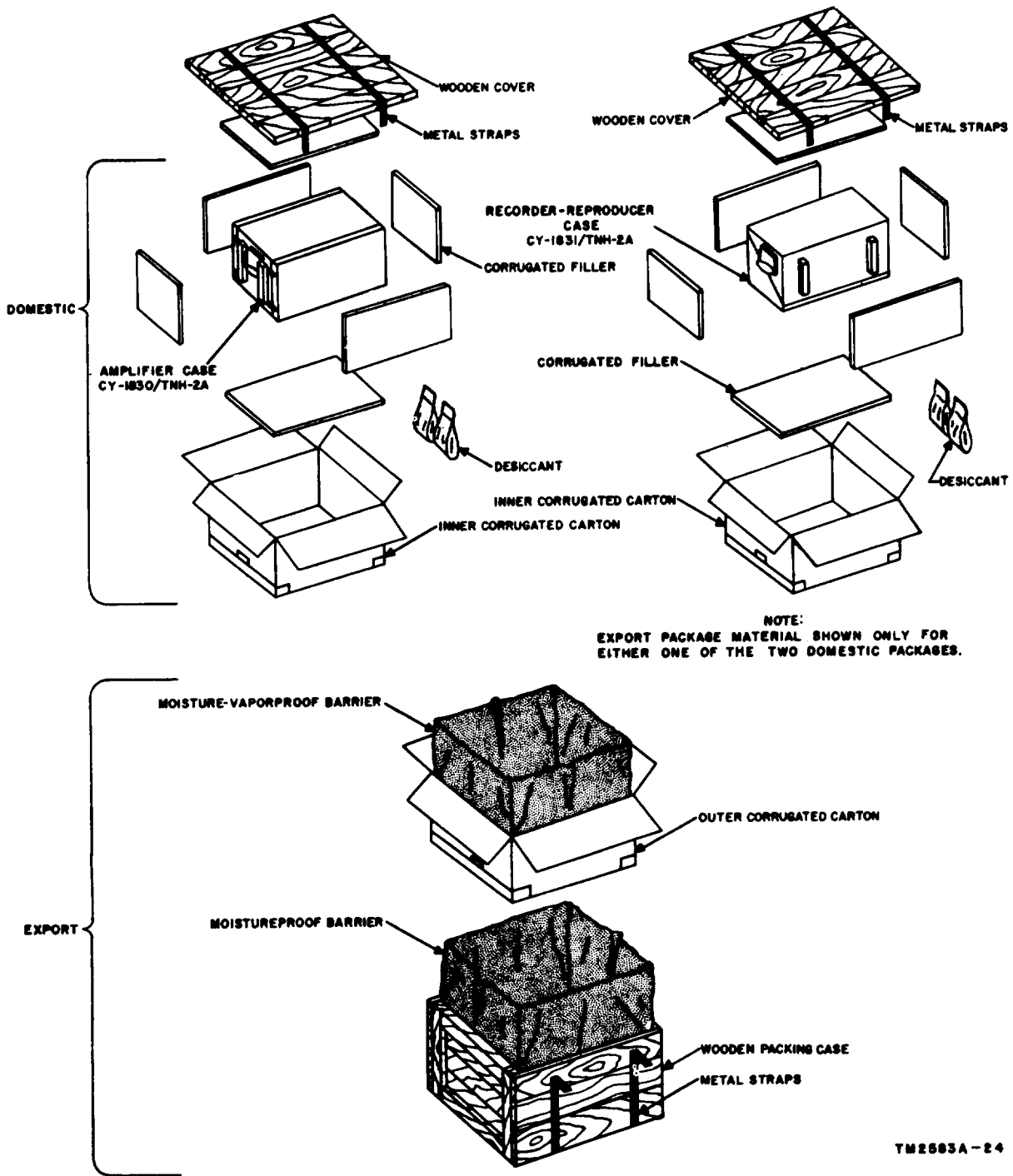

TM2583A-24

Figure 5. Sound Recorder-Reproducer Set AN TNH-2A, packing and packaging diagram.

and insert the female connector of the interconnecting power cable in the input power connector (fig. 12) on the rear of the amplifier chassis. Connect the male connector of the cable to a 115-volt 60-cycle per second (cps) power source.

*Note.* For telephone recordings, insert the male connector of the interconnecting power cable in the AUX OUTLET receptacle as described in paragraph 11.

*c. Setting up Equipment in Rack (fig. 6).*

- (1) To rack-mount the equipment, remove the four screws that hold the amplifier to its carrying case; remove the four screws that hold the audio amplifier to its carrying case, and remove the eight screws that hold the recorder-reproducer to its carrying case.
- (2) Lift the recorder-reproducer out of the carrying case and disconnect all cables. Identify each cable with a tag to indicate the correct connections.
- (3) Install the recorder-reproducer in a vertical position in a standard rack. Below the recorder-reproducer, install the amplifier, and below the amplifier install the audio amplifier.
- (4) Connect each cable to the proper connectors.

**11. Connections to Telephone or Program Line**

(fig. 9)

*a. Telephone Line Connection.* The recorder-reproducer set must be connected to a telephone line through authorized equipment such as Tone Warning Group OA-145/GT (refer to TM 11-2088 Tone Warning Group OA-145/GT). The OA-145/GT provides an audible note that informs the telephone user that the conversation is being recorded. To connect the OA-145/GT to the recorder-reproducer set, set up the equipment (par. 10) and proceed as follows :

- (1) Turn the INPUT SELECTOR SWITCH of the amplifier to the 600 BAL. position (fig. 12).
- (2) Rotate the RECORD LEVEL control to the 5 position. This setting may have to be changed later during the

recording operation to increase or decrease signal strength as required.

- (3) Insert the telephone plug, at the end of the headset cord, in the EAR-PHONES jack.
- (4) Connect the male connector of the power cable to the AUX OUTLET receptacle at the rear of Tone Warning Generator Control C-638/GT.
- (5) Modify Special Purpose Cable Assembly CX-1278/U (part of the OA-145/GT ) as follows:
  - (a) Remove the plug from one end and replace it with a suitable connector to mate with the INPUT connector of the amplifier of the recorder-reproducer set.
  - (b) Dress the end of the black conductor and solder it to terminal 2 of the connector.
  - (c) Dress the end of the white conductor and connect it to terminal 3 of the connector.
  - (d) Connect the cable shield to terminal 1 of the conductor.
- (6) Connect the components of Tone Warning Group OA-145/GT as described in TM 11-2088. Connect the amplifier INPUT connector through the CX-1278/U to terminals marked *T*, *R*, and *S* of the terminal board marked RECORDER INPUT located on the rear of the C-638/GT as follows:
  - (a) Connect the spade terminal of the black wire of the CX-1278/U to the terminal marked *T*.
  - (b) Connect the spade terminal of the white wire of the CX-1278/U to the terminal marked *R*.
  - (c) Connect the shield of the CX-1278/U to the terminal marked *S*.
- (7) Connect the power cable of the C-638/GT to a 115-volt 60-cps power source.

*Note.* With The recorder-reproducer set and the tone warning group connected as described above, the equip Tent will start to record telephone conversations when the PLAY and RECORD switches are pressed (par. 15).

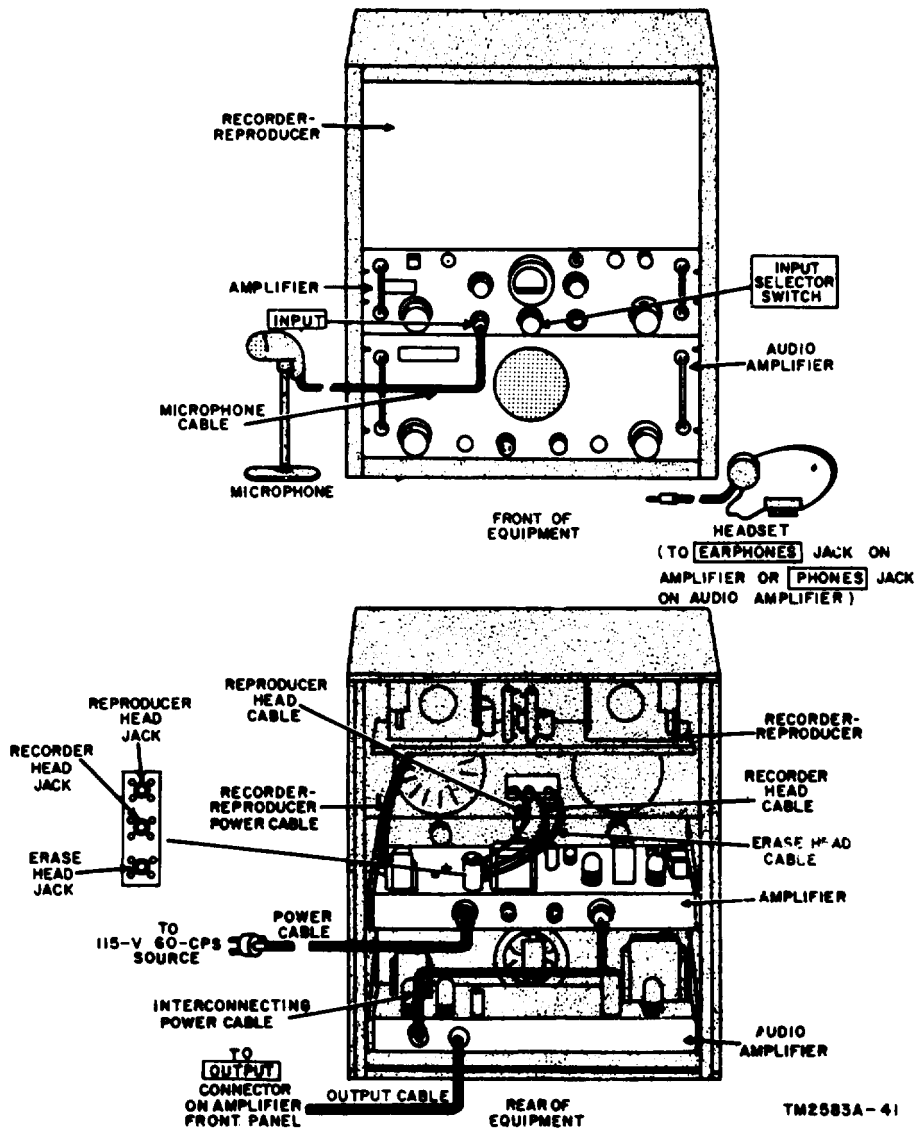

Figure 6. Interconnection diagram (rack mounting shown).

*b. Program Line Connections (fig. 10).* The connection between the recorder-reproducer set and the program line consists of a two-conductor shielded cord terminated at one end with a connector suitable for connection to the program line and at the other end with a female connector that mates with the INPUT connector on the amplifier. To connect the equipment, proceed as follows:

- (1) Set up the equipment (par. 10).
- (2) Fabricate the connecting cord to the required length and terminate the cord with appropriate connectors.
- (3) Connect the two-conductor shielded cable across the program line. Connect the other end of the cable to the INPUT connector on the amplifier.
- (4) Turn the INPUT SELECTOR SWITCH to the 600 BAL. position for a balanced line; to the 600 UNBAL. position for an unbalanced line; or to the BRIDGE position if bridging is

desired. (Bridging is used to avoid loading a program line excessively by utilizing the relatively high-impedance bridging input circuit of the amplifier.)

- (5) Insert the plug at the end of the headset cord into the EARPHONES jack.

## **12. Service Upon Receipt of Used or Reconditioned Equipment**

*a.* Follow the instructions given in paragraph 9 for unpacking and checking the equipment.

*b.* Check the used or reconditioned equipment for tags or other indications of changes in wiring of the equipment. Note the changes in appropriate places in the technical manual.

*c.* Check all operating controls for ease of operation.

*d.* Install the equipment, if necessary, as directed in paragraph 10.

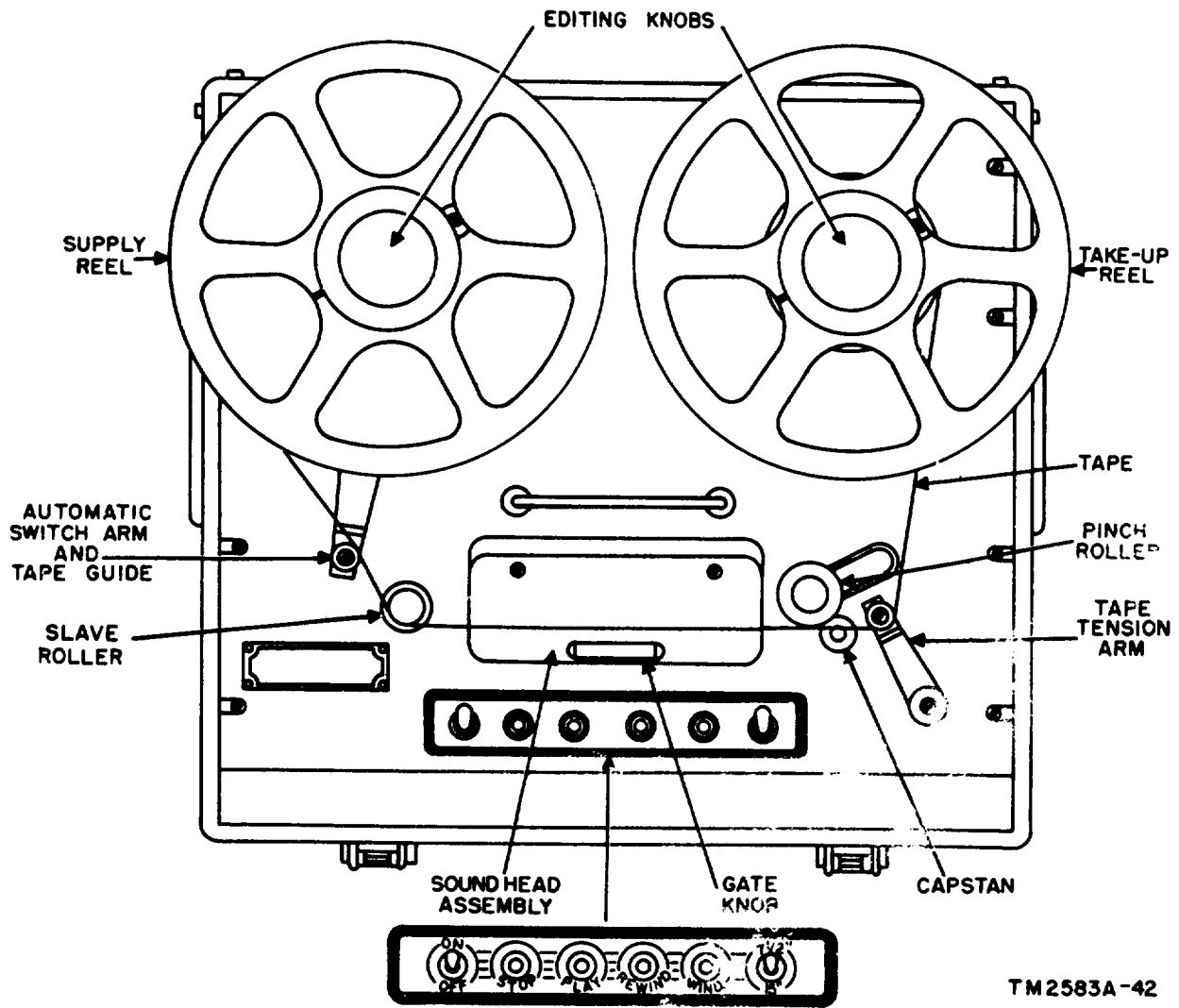

Figure 7. Tape threading diagram.

## CHAPTER 3

### OPERATION

---

#### Section I. OPERATION UNDER USUAL CONDITIONS

##### 13. Preliminary Procedure

- a.* Install the equipment (par. 10).
- b.* Turn the editing knobs (fig. 7) on the supply reel and the take-up reel spindles counterclockwise and lift the knobs off the spindles.
- c.* Insert the hub adapter (located on the spindles into the reel before mounting; do not mount the reels on the hub adapters. Mount a full reel of tape on the supply reel (left-hand) spindle, and mount an empty take-up reel on the take-up (right-hand) spindle (fig. 7).
- d.* Place the editing knobs on the reels; be sure that the pin on the spindle is engaged in the hole in the editing knob; push the knob. Tighten the knob by turning it clockwise.
- e.* Open the gate on the sound head assembly by pulling the gate knob (fig. 7).
- f.* Remove and discard the adhesive tape from the end of the recording tape.
- g.* Thread the tape in the path indicated in figure 7. Insert the end of the tape in one of the slots in the take-up reel. Turn the take-up reel 2 or 3 turns counterclockwise to wind the tape onto the reel and also to remove any slack in the tape.
- h.* Close the tape gate by pushing the gate knob. This will assure that the tape fits against the recorder-reproducer, and erase heads in the sound head assembly.

##### 14. Microphone Recording (fig. 8)

During the recording operation, intelligence stored on the tape will be erased (removed) before new intelligence is recorded. To record with a microphone, proceed as follows:

- a.* Connect and prepare the equipment for operation (par. 10 and 13).

- b.* Move the 7½ 15" switch on the recorder-reproducer (fig. 7) to the desired speed.

- c.* Turn the EQUALIZATION switch of the amplifier (fig. 12) to the 7½ I.P.S. or the 15 I.P.S. position to correspond with the setting indicated in *b* above.

- d.* Move the ON-OFF switch on the recorder-reproducer to the ON position.

- e.* Press the PLAY switch on the recorder-reproducer.

- f.* Press the RECORD switch on the amplifier; the RECORD INDICATOR should glow.

- g.* Talk into the microphone in a normal manner. Adjust the RECORD LEVEL control (fig. 12) until the meter indicates 100 on sound peaks. A decrease in distance between the operator's mouth and the microphone may cause the meter needle to indicate above 100. If this should happen, increase the distance rather than reset the RECORD LEVEL control.

- h.* When the recording is completed, press the STOP switch on the recorder-reproducer.

- i.* To start recording again, repeat the instructions given in *e*, *f* and *g* above.

- j.* If a recording requires more than one reel of tape, have additional reels for immediate use to minimize loss of desired recorded intelligence. Identify each reel to assure continuity of playback.

- k.* If a playback is desired to establish a recording continuity, follow the playback operation procedures outlined in paragraph 18.

- l.* If two or more programs or sets of intelligence are to be recorded on the same tape, be sure that a dead space (no recorded information) is provided between the two programs or sets of intelligence.

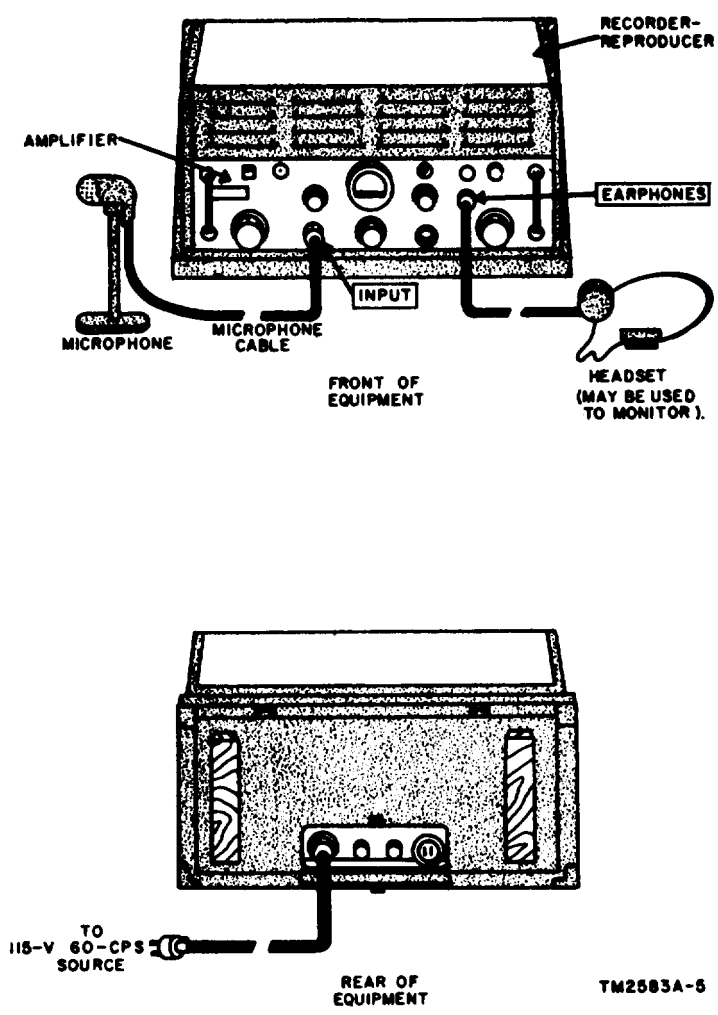

Figure 8. Equipment setup for microphone recording.



*m.* If it is desired to record intelligence on the second track of the tape, remove the editing knobs on the reels, remove the reels and re-install the reels in the following manner:

- (1) Turn the full reel (the reel of tape just recorded) upside down.
- (2) Place the full reel on the supply spindle (left-hand), and place the empty reel on the take-up reel spindle (right-hand).
- (3) Thread the tape (par. 13) and repeat instructions given in *e*, *f*, *g*, and *h* above.

*n.* Stop the equipment as directed in paragraph 23.

### 15. Telephone Line Recording (fig. 9)

To record a telephone conversation, proceed as follows:

*a.* Install the recorder-reproducer set and connect Tone Warning Group OA-145/GT as described in paragraphs 10 and 11 respectively, and as shown in figure 9.

*b.* Operate Tone Warning Generator Control C-638/GT as directed in TM 11-2088.

*c.* Insert the connector on the end of the headset cord in the EARPHONES jack on the amplifier panel (fig. 12).

*d.* Listen in with the headset. When the conversation begins, press the PLAY and then the RECORD switches on the recorder-reproducer and on the amplifier; the RECORD indicator of the amplifier should glow. Adjust the RECORD LEVEL control until the vu meter indicates between 60 and 100 (-3 to 0 decibels (db)). The vu meter should indicate 100 on sound peaks.

*e.* At the end of the conversation, press the STOP switch on the recorder-reproducer.

*f.* Continue to listen *in* with the headset. If the telephone conversations are frequent, provide about ½ minute of dead tape between recordings.

*g.* At the end of the recording, move the ON-OFF switch on the recorder-reproducer to the OFF position. All pilot lamps should extinguish.

*h.* If no further recordings are anticipated, stop the recorder-reproducer set (par. 23).

### 16. Program Line Recording (fig. 10)

To record from a program line, proceed as follows:

*a.* Install and connect the equipment (par. 10 and 11).

*b.* Make the necessary connections for monitoring (par. 17).

*c.* Thread the tape (par. 13).

*d.* Move the ON-OFF switch to the ON position. Allow 5 minutes for warm up.

*e.* Monitor the incoming program using the headset or loudspeaker (par. 17). Adjust the RECORD LEVEL control until the vu meter indicates 100 on sound peaks.

*f.* When ready to record, press the PLAY switch on the recorder-reproducer and the RECORD switch on the amplifier.

*g.* If the tape runs out, reverse the tape (par. 14*m*) and record on the second track.

*h.* At the end of the recording period, press the STOP switch on the recorder-reproducer. Stop the equipment (par. 23).

### 17. Monitoring Operation

Monitoring a recording may be accomplished by using the headset with the amplifier or by using the headset or the loudspeaker with the audio amplifier. The necessary connections anti switch positions required for preparing the recorder-reproducer set for monitoring are covered in *a* below. The monitoring operation is outlined in *b* below.

*a. Providing for Monitoring.*

(1) *Amplifier.* Proceed as follows:

(a) Insert the headset plug in the EARPHONES jack on the amplifier panel (fig. 12).

(b) Move the LINE TERMINATION switch to the OFF position.

(c) Monitor the recording (par. 15 or 16) as described in *b* below.

(2) *Audio amplifier.* Proceed as follows:

(a) Open the access door at the side of audio amplifier carrying case and check to see that the female connector at the end of the interconnecting power cable is connected to the male connector on the rear panel of the audio amplifier. Also check to

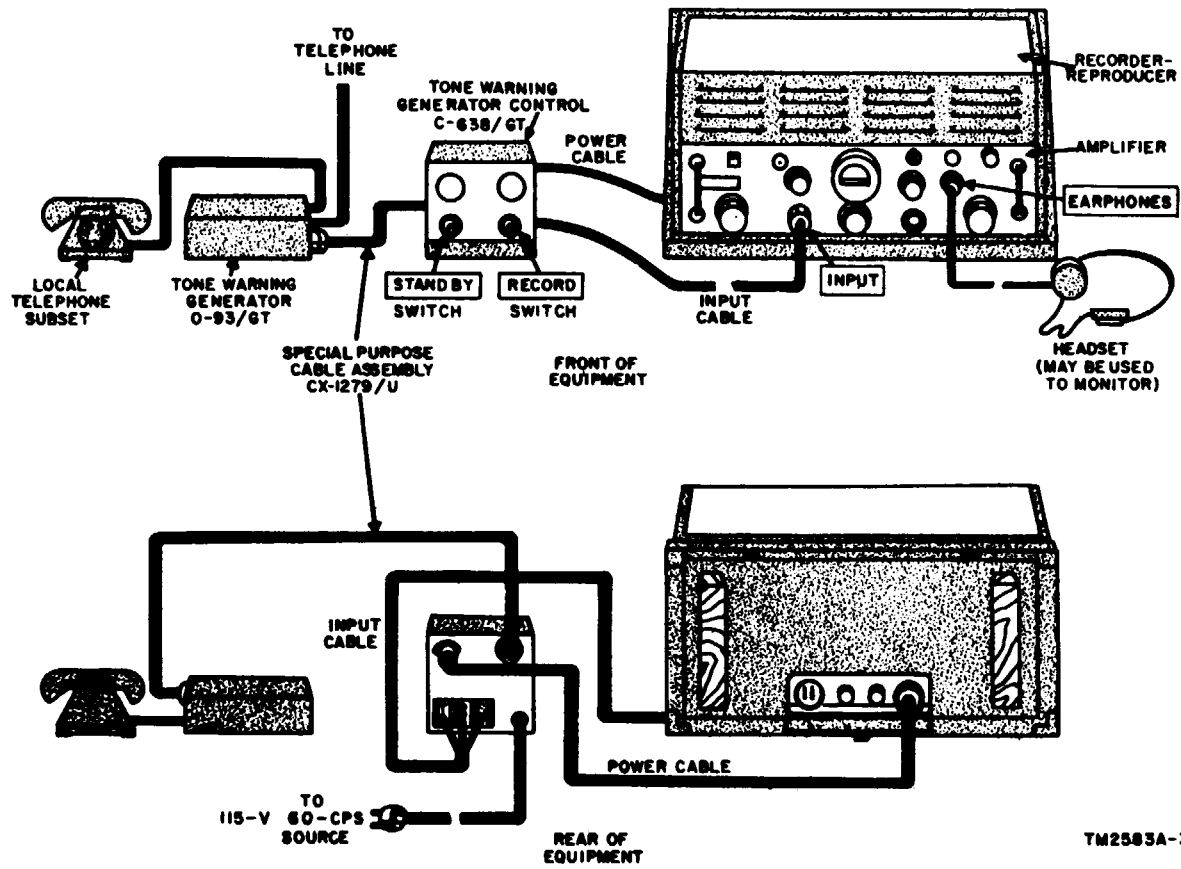

TM2583A-3

Figure 9. Equipment setup for telephone recording.

see that the male connector at the other end of the interconnecting power cable is inserted in the female connector at the rear of the amplifier chassis.

- (b) Insert the headset plug in the PHONES jack on the audio amplifier panel (fig. 13).
- (c) Turn the function switch to the PHONES position and monitor the recording as described in *b* below. To monitor, using the self-contained loudspeaker, turn the function switch to the SPEAKER position. To use the headset and the loudspeaker, turn the function switch to the SPEAKER PHONES position.

*b. Monitoring a Recording.* The following monitoring procedure applies to either the amplifier (*a(1)* above) or the audio amplifier (*a(2)* above). Proceed as follows:

- (1) Listen to the recording for quality. Turn the METER SELECTOR switch to the RECORD LEVEL position. If required, adjust the RECORD LEVEL control to keep the vu meter indicator from passing the 100 mark on the sound peaks.
- (2) Turn the METER SELECTOR switch to the BIAS position. The vu meter should indicate 100.
- (3) Turn the METER SELECTOR switch to the ERASE position. The vu meter should indicate 100.
- (4) Adjust the PLAYBACK LEVEL or MONITOR LEVEL control (fig. 12 and 13), depending upon which amplifier is being used, for comfortable sound volume in the headset. For control of loudspeaker volume, adjust the MONITOR LEVEL control only.
- (5) Return the METER SELECTOR switch to the RECORD LEVEL position and adjust the RECORD LEVEL control as required during the recording to keep the vu meter indicator from passing the 100 mark on sound peaks.

## 18. Reproducing or Playback Operation (fig. 11)

To playback a recording, proceed as follows:

- a. Connect and prepare the equipment (par. 10 and 13).
- b. Move the METER SELECTOR switch to the PLAYBACK LEVEL position (fig. 12).
- c. Set the PLAYBACK LEVEL control to the 8 position. This setting may have to be changed during operation.
- d. Connect a headset to the PHONES (fig. 13) or EARPHONES (fig. 12) jack. If the headset is connected to the PHONES jack on the audio amplifier, move the function switch to the PHONES position. If the information is to be played back for a small audience, move the function switch to the SPEAKER or the SPEAKER PHONES position.
- e. To serve a large group of listeners located at some distance from the equipment, use a suitable external loudspeaker (par. 4). Insert the external loudspeaker plug in the EXTERNAL SPEAKER jack on the audio amplifier, and turn the function switch to either the SPEAKER or the SPEAKER PHONES position. This will disconnect the internal loudspeaker.
- f. Be sure that the recorded reel of tape is in place on the supply reel spindle.
- g. Move the ON-OFF switch to the ON position; wait about 5 minutes. When ready to play back, press the PLAY switch on the recorder-reproducer.
- h. To select the portion of tape to play, wind or rewind the tape for the desired information (par. 19 and 20). After reaching the approximate location of the desired material on the tape, use the editing knobs (fig. 7) to rotate the reels as required to reach the exact location.
- i. Adjust the sound level by rotating the PLAYBACK LEVEL control to the desired setting.
- j. When finished with the playback operation, press the STOP switch on the recorder-reproducer. Stop the equipment (par. 23).

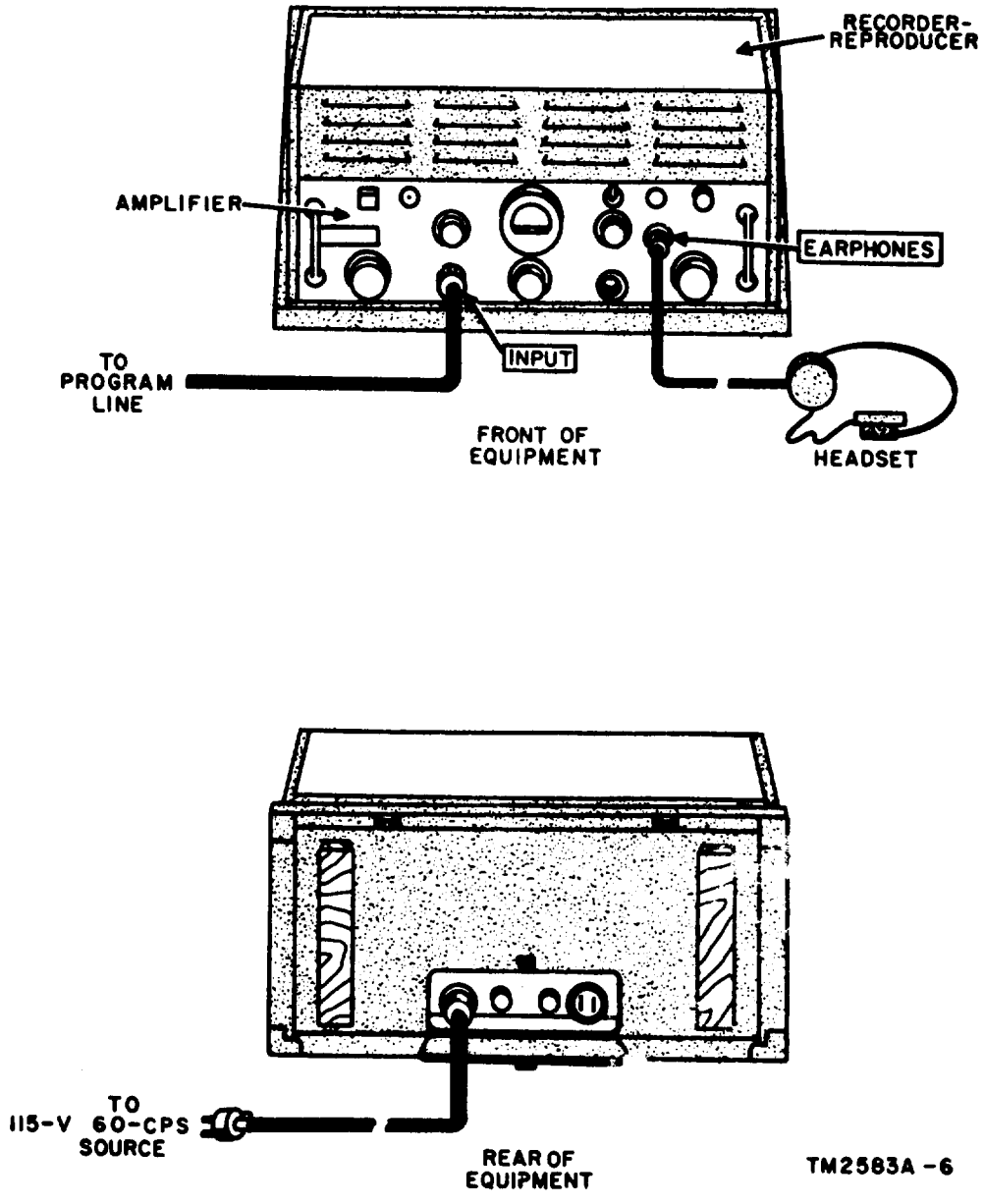

Figure 10. Equipment setup for program line recording.

## 19. Rewinding Operation

To rewind the tape, proceed as follows:

*a.* At the end of a recording or playback operation, press the STOP switch on the recorder-reproducer.

*b.* Grasp the gate knob on the sound head assembly (fig. 7) and open the gate.

*c.* Press the REWIND switch. One minute is required to rewind a full 10 ½-inch reel. The equipment will shut down when the end of the tape comes off the take-up reel and frees the automatic switch arm and tape guide (fig. 7).

*d.* If a full tape rewind is not necessary, press the STOP switch and close the gate on the soundhead after rewinding the tape to the approximate location; use the editing knobs (fig. 7) to find the desired recording. Recording or reproducing is not possible unless the gate is closed.

*e.* If the tape breaks during rewind, the equipment will stop. Splice tape as directed in paragraph 22.

## 20. Fast Forward Operation

To wind the tape quickly, proceed as follows:

*a.* Grasp the gate knob on the soundhead assembly (fig. 7), and open the gate.

*b.* Press the WIND switch. One minute is required to wind a full 10½ inch reel of tape.

*c.* When the desired portion of tape becomes available, press the STOP switch. Close the gate and use the editing knobs to locate the exact place on the tape.

*d.* If the tape breaks during the fast wind operation, the equipment will stop. Splice the tape as directed in paragraph 22.

## 21 Public Address Operation

(fig. 11)

To use the recorder-reproducer set as a public address set, proceed as follows:

*a.* Connect the equipment as directed in paragraphs 10 and 13.

*b.* Connect the microphone to the INPUT connector on the amplifier (fig. 12).

*c.* Move the INPUT SELECTOR SWITCH to the MIC position.

*d.* Adjust the MONITOR LEVEL control on the audio amplifier to the 5 position. This setting may have to be changed later.

*e.* Move the METER SELECTOR switch to the RECORD LEVEL position.

*f.* Move the function switch on the audio amplifier to the SPEAKER position.

*g.* Connect a suitable external loudspeaker (par. 4) to the EXTERNAL SPEAKER jack on the audio amplifier.

*h.* Move the ON-OFF switch to the ON position; wait about 6 minutes.

*i.* Speak into the microphone. Adjust the MONITOR LEVEL control on the audio amplifier for the desired level of sound. If the howling (acoustic feedback) occurs, either the speech delivery is too loud, the setting of the MONITOR control is too high, or the microphone is not located correctly. Correct this condition by relocating the loudspeaker or microphone.

*j.* At the end of the delivery, stop the equipment as directed in paragraph 23.

## 22. Splicing Tape

Splice recording tape as follows:

*a.* Place the two loose ends together glossy side up; be sure to overlap the ends about ½ inch and cut across the ends at a 46° angle.

*b.* Place the ends of the tape on a flat surface, with the glossy side of the tape up.

*c.* Butt the ends together and secure them with splicing tape, or ordinary gummed cellulose (Scotch) tape. Be sure that the splicing tape is placed parallel to the cut ends, and then press firmly.

*d.* Trim the splicing tape, so that the spliced joint is slightly narrower than the tape. This will prevent jamming of the tape when the tape is pulled past the sound heads.

## 23. Stopping Operation

To stop the equipment, proceed as follows:

*a.* Press the STOP switch on the recorder-reproducer (fig. 7).

*b.* Move the ON-OFF switch on the recorder-reproducer to the OFF position.

*c.* Turn the RECORD LEVEL and the PLAYBACK LEVEL controls to the 0 position. Also turn the MONITOR LEVEL control to the 0 position.

*d.* Remove the power cable plug from the power receptacle if the equipment is to be out of service for a long period of time.

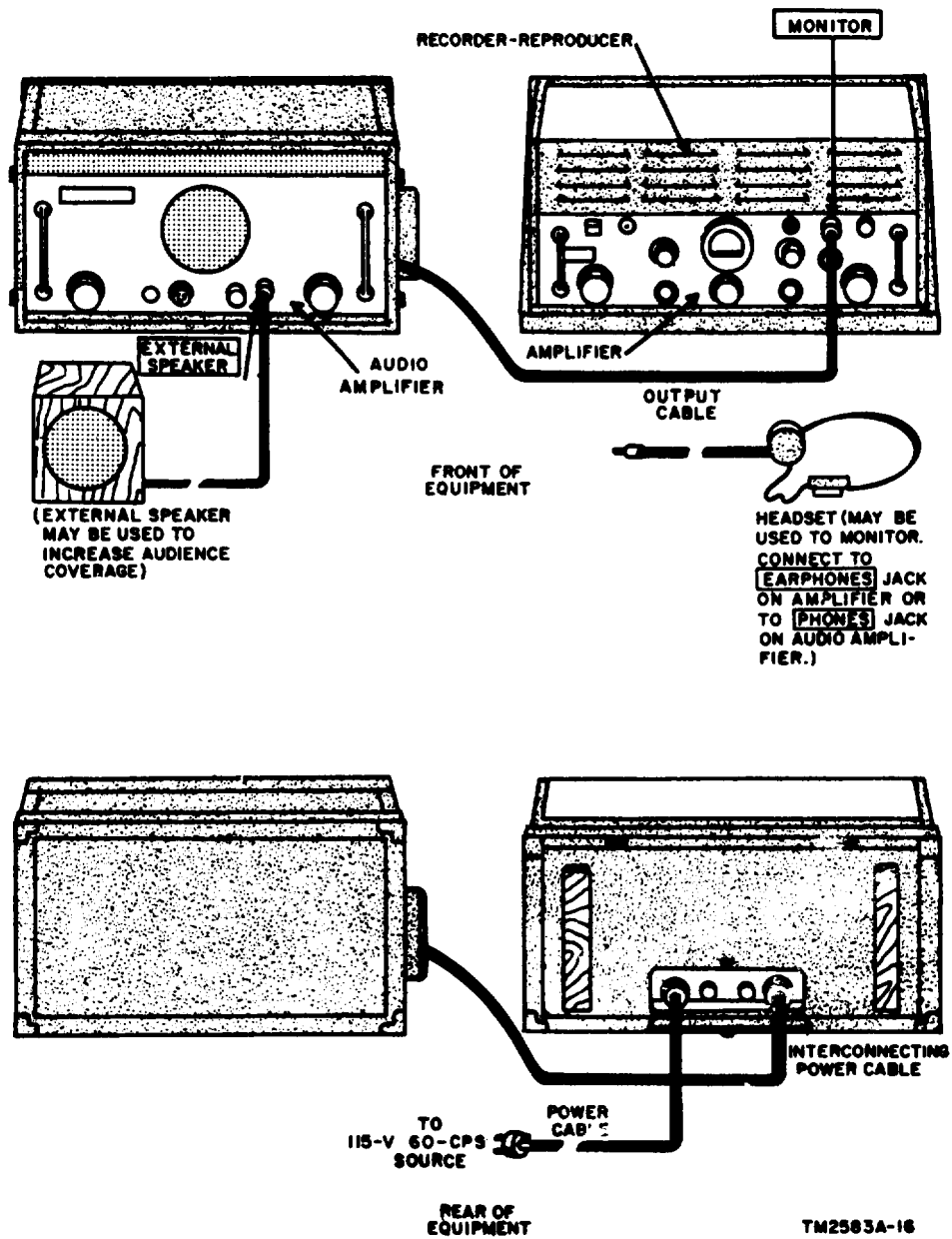

Figure 11. Equipment setup for playback

## Section II. OPERATION UNDER UNUSUAL CONDITIONS

### 24. General

The operation of the recorder-reproducer set may be difficult in regions where extreme cold, heat, humidity and moisture, or sand conditions prevail. Procedures that minimize the effects of these unusual climatic conditions are given in paragraphs 25, 26, and 27.

### 25. Operation in Arctic Climate

Extreme cold followed by moisture-laden warmth causes condensation to form on and in the equipment. A high B voltage across wet terminals may cause damaging current paths to form. Dry the equipment thoroughly. Cover the equipment immediately after use to retain equipment operating temperature for a longer time.

### 26. Operation in Desert Climates

To prevent equipment failure in areas subject to extremely high temperatures, low humidity, and excessive sand, dust, and dirt, operate the equipment in a sandproof shelter. When not in use, keep the equipment covered to keep out sand, dirt, and dust.

### 27. Operation in Tropical Climates

In damp, tropical climates of high relative humidity, condensation occurs on and in the equipment whenever the temperature of the equipment is sufficiently lower than the warm, moisture-laden air. To minimize this condition, cover the equipment immediately after use to retain the dry heat. Turn the equipment on daily to generate enough dry heat to insure freedom from the effects of moisture and fungus growth.

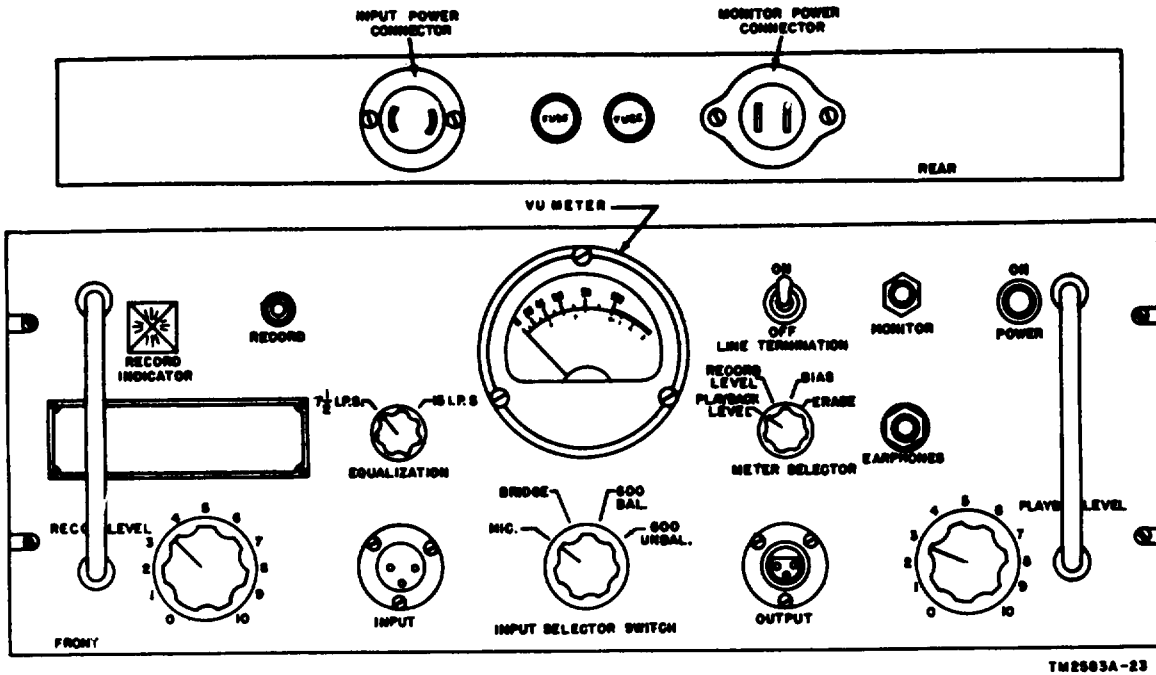

Figure 12. Amplifier, front and rear panels.

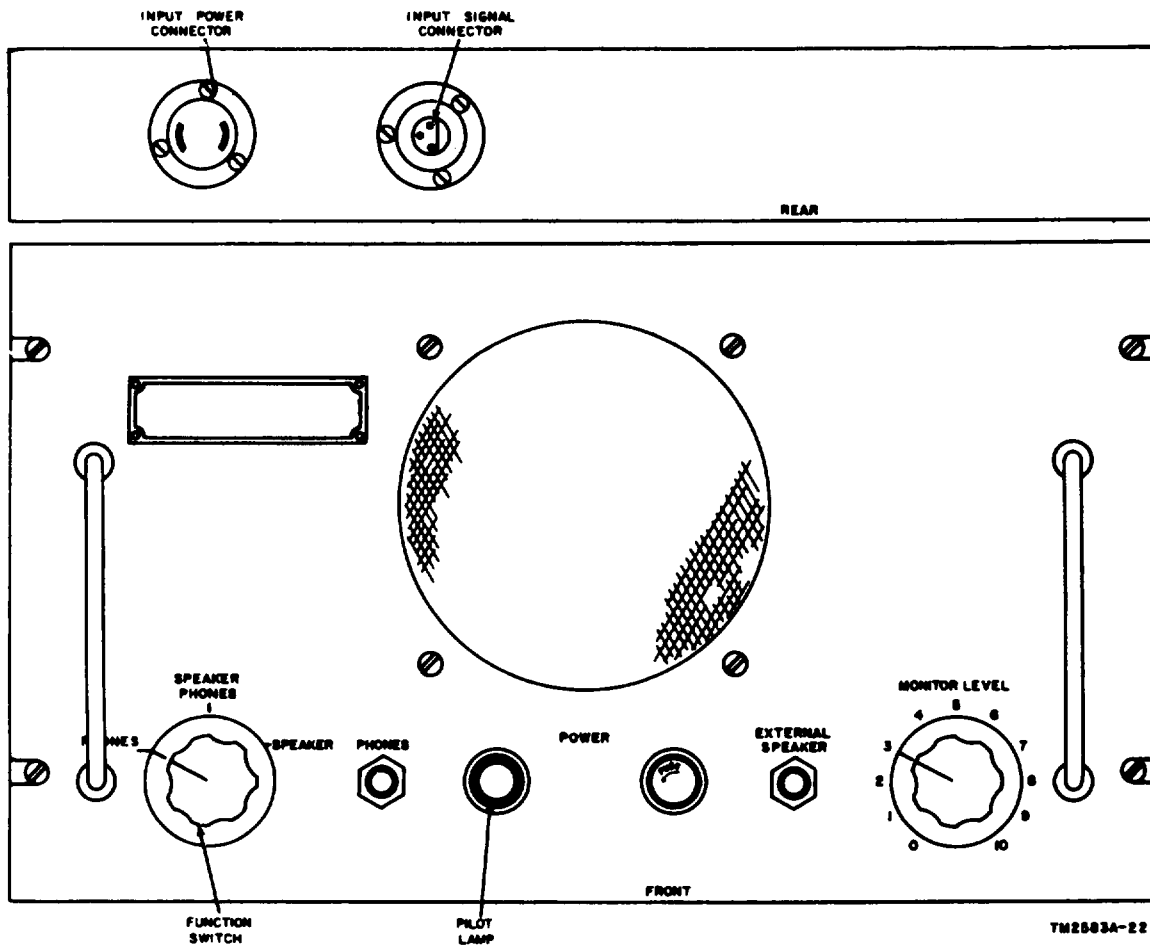

Figure 13. Audio amplifier, front and rear panels.



## CHAPTER 4

### ORGANIZATIONAL MAINTENANCE

#### Section 1. CONTROLS AND INSTRUMENTS

*Note.* This section describes, locates, and illustrates the operating controls and instruments.

#### 28. Controls and Indicators and Their Uses (fig. 7, 12 and 13)

The following charts list the controls and indicators on the front panels of the components of the recorder-reproducer set and describe the function of each.

##### *a. Amplifier (fig. 12).*

Control	Function
RECORD INDICATOR	Neon lamp; indicates that equipment is ready to record.
RECORD switch	When pushed, arranges circuits for the recording function, causes the RECORD INDICATOR to light and starts tape movement (if the PLAY (b below) switch has been pressed first).
EQUALIZATION switch	Rotary switch; increases the high frequency response of the recording amplifier for 7 1/2-ips operation.
Vu meter	Indicates recording level, playback level, bias level and erase-oscillator current as selected by operation of the METER SELECTION switch.
LINE TERMINATION switch	In the OFF position, provides for better impedance matching between the amplifier and audio amplifier. In the ON position, permits suitable disconnection of audio amplifier from amplifier by providing substitute loading of the playback amplifier output.

Control	Function
METER SELECTOR switch	Four-position switch used as follows: PLAYBACK LEVEL: indicates the playback amplifier output. RECORD LEVEL: indicates recording amplifier output. BIAS: indicates bias level. ERASE: indicates erase-oscillator current.
ON-POWER	Pilot light; indicates power is connected to the amplifier and audio amplifier.
RECORD LEVEL control	Adjusts the signal level for the recording operation.
INPUT SELECTOR SWITCH	Four-position switch; provides for the following types of input: MIC. for microphone; BRIDGE for high impedance; 600 BAL. for 600 ohms balanced line; 600 UNBAL. for 600 ohms unbalanced line.
PLAYBACK LEVEL control	Adjusts the playback signal level.

##### *b. Recorder-Reproducer (fig. 7).*

Control	Function
ON-OFF switch	Opens and closes the ac power circuit for the entire equipment.
STOP switch	Energizes the brake circuit; stops rotation of the take-up and the supply motors; closes the circuit to the solenoid to release the capstan roller; stops tape movement.



Lint-free cloth  
Oil, Lubricating, Aircraft Instrument  
(OAI)  
Sandpaper, #0000  
Cleaning Compound (Fed stock No.  
7930-395-9542)

Petrolatum, technical, (PET)  
Electron Tube Test Set TV-7/U  
Multimeter TS-297/U  
Tool Equipment TS-113

### Section III. PREVENTIVE MAINTENANCE SERVICES

#### 32. Definition of Preventive Maintenance

Preventive maintenance is work performed on equipment (usually when the equipment is not in use) to keep it in good working order. Preventive maintenance minimizes equipment breakdowns and interruptions in service.

#### 33. Use of Preventive Maintenance Forms (fig. 14 and 15)

##### a. DA Form 11-250.

- (1) DA Form 11-250 is a preventive maintenance check list to be used by the operator as directed by his commander.
- (2) Items not applicable to the recorder-reproducer set are lined out on figure 14. References in the ITEM block in the figure are to paragraphs in this manual which contain additional maintenance information pertinent to the particular item.

##### b. DA Form 11-251.

- (1) DA Form 11-251 is a preventive maintenance check list to be used by a second echelon repairman as directed by his commander.
- (2) Items not applicable to the recorder-reproducer set are lined out on figure 13. References in the ITEM block in the figure are to paragraphs in this manual which contain additional maintenance information pertinent to the particular item.

#### 34. Preventive Maintenance Techniques

Recommended materials are listed in paragraph 31. Good preventive maintenance practice requires that all fittings, screws, bolts, and nuts be tightened carefully to avoid stripping and other damage. It is important to remove Cleaning Compound residue with a clean lint-free cloth. Use only Cleaning Compound on

electrical contacts, then wipe the contacts dry. Corrosion may be removed with #0000 sandpaper and Cleaning Compound.

Caution. Prolonged breathing of Cleaning Compound fumes is dangerous. Be sure that adequate ventilation is provided. Cleaning Compound is flammable; do not use it near a flame.

##### a. Daily Items.

- (1) Check for completeness and general condition of the equipment. The components are listed in paragraph 5.
- (2) Remove dirt and moisture from the carrying cases, the front panels, controls, connectors, power receptacles, tape reels, tape, and all mechanical parts on the panels.
- (3) Inspect the seating of all fuses of the amplifier and the audio amplifier.
- (4) Inspect the seating of all pilot lamps.
- (5) Inspect all operating controls for binding, scraping, excessive looseness, and positive action.

##### b. Weekly Items.

- (1) Check all connectors for chips, cracks, or corrosion.
- (2) Inspect the exposed surfaces of both carrying cases for rust, corrosion, or mildew.
- (3) Inspect the panels of all units for rust, corrosion, scratches, and damaged finishes.
- (4) Inspect the power cable and other cables for kinks, breaks, deterioration, and loose connections.
- (5) Inspect the control knobs, switch knobs, and meter for looseness. Check all exterior fastenings.
- (6) Inspect the meter for damaged glass or case.
- (7) Clean and inspect the microphone and headset.

OPERATOR FIRST ECHELON MAINTENANCE CHECK LIST FOR SIGNAL CORPS EQUIPMENT PUBLIC ADDRESS, RECORDER, REPRODUCER									
<i>INSTRUCTIONS: See other side</i>									
EQUIPMENT NOMENCLATURE <b>SOUND RECORDER-REPRODUCER SET AN/TNH-2A</b>					EQUIPMENT SERIAL NO. <b>149</b>				
LEGEND FOR MARKING CONDITIONS: ✓ Satisfactory; I Adjustment, repair or replacement required; ⊗ Defect corrected. NOTE: Strike out items not applicable.									
DAILY									
NO.	ITEM	CONDITION							
		S	M	T	W	T	F	S	
1	INSPECT UNIT FOR COMPLETENESS - MICROPHONE, HEADSET, CORDS, CABLES, ACCESSORIES, RUNNING SPARES. <b>PAR. 6</b>	✓							
2	CLEAN EXTERIOR OF COMPONENTS OF DIRT, GREASE, GRIME, CORROSION, OIL. <b>PAR. 34a(2)</b>	✓							
3	CLEAN PLUGS AND ELECTRICAL CONNECTIONS OF CORROSION, TARNISH, DIRT, DUST, GREASE, OIL. <b>PAR. 34a(2)</b>	⊗							
WEEKLY									
NO.	ITEM	COND- TION	NO.	ITEM	COND- TION				
4	INSPECT EXTERIOR OF COMPONENTS FOR RUST, CORROSION, LOOSE OR MISSING SCREWS, CHIPPED PAINT, CRACKS. <b>PAR. 34b(1),(2),(3)</b>	✓	7	INSPECT ELECTRICAL CONNECTIONS FOR FIRMNESS OF SEATING, PROPER CONTACT, TIGHTNESS, CORROSION, GREASE, OIL, DIRT. <b>PAR. 34a(2)</b>	✓				
5	INSPECT CORDS AND CABLES FOR LOOSE TERMINALS, FRAYED, CUT OR BOUNDED INSULATION OR JACKETING, BROKEN CONDUCTORS. <b>PAR. 34b(4)</b>	✓	8	INSPECT PLUGS FOR CHIPS, CRACKS, CORROSION, TARNISH, ROUGHNESS, BENDS. <b>PAR. 34b(1)</b>	⊗				
6	TIGHTEN - LOOSE EXTERIOR SCREWS, BOLTS, FASTENINGS, MOUNTINGS. <b>PAR. 34b(5)</b>	✓	9	OPERATE UNIT AND CHECK FOR SMOOTHNESS, UNUSUAL NOISES, SQUEAKS, VIBRATIONS, CORRECT OPERATION. <b>PAR. 34b</b>	✓				
10 IF DEFICIENCIES NOTED ARE NOT CORRECTED DURING INSPECTION, INDICATE ACTION TAKEN FOR CORRECTION.									

**DA FORM 11-250**  
1 MAY 51

REPLACES DA AGO FORM 419, 1 DEC 50, WHICH IS OBSOLETE.

TM258 3A-46

Figure 14. DA Form 11-250.

SECOND AND THIRD ECHELON MAINTENANCE CHECK LIST FOR SIGNAL CORPS EQUIPMENT PUBLIC ADDRESS, RECORDER, REPRODUCER					
INSTRUCTIONS: See other side					
EQUIPMENT NOMENCLATURE SOUND RECORDER - REPRODUCER SET AN/TMH-2A			EQUIPMENT SERIAL NO. 149		
LEGEND FOR MARKING CONDITIONS: ✓ Satisfactory; ✗ Adjustment, repair or replacement required; ⊕ Defect corrected. NOTE: Strike out items not applicable.					
NO.	ITEM	COMPL. DATE	NO.	ITEM	COMPL. DATE
1	INSPECT UNIT FOR COMPLETENESS - MICROPHONE, HEADSET, CORDS, CABLES, ACCESSORIES, RUNNING SPARES.  PAR 34c(1)	✓	13	SOLDER ANY BROKEN OR LOOSE SOLDERED CONNECTIONS.  PAR 34c(11)	✓
2	CLEAN EXTERIOR OF COMPONENTS OF DIRT, GREASE, GRIME, CORROSION, OIL.  PAR 34a(2)	✓	14	INSPECT INTERNAL WIRING AND CABLING, WHERE ACCESSIBLE FOR LOOSE TERMINALS, FRADED, CUT, OR GOUGED INSULATION OR JACKETING, BROKEN CONDUCTORS.  PAR 34b	✓
3	CLEAN PLUGS AND ELECTRICAL CONNECTIONS OF CORROSION, TARNISH, DIRT, DUST, GREASE, OIL.  PAR 34a(2)	⊕	15	INSPECT MOTORS FOR CONDITION OF BRUSHES, EVIDENCES OF OVERHEATING, LHO PLAT, SIDE PLAT.  PAR 34c(12)	✓
4	INSPECT EXTERIOR OF COMPONENTS FOR RUST, CORROSION, LOOSE OR MISSING SCREWS, CHIPPED PAINT, CRACKS.  PAR 34b(1),(2),(3)	✓	16	INSPECT REPRODUCER AND/OR RECORDER HEADS FOR GENERAL CONDITION.  PAR 34c(9)	✓
5	INSPECT CORDS AND CABLES FOR LOOSE TERMINALS, FRADED, CUT OR GOUGED INSULATION OR JACKETING, BROKEN CONDUCTORS.  PAR 34b(4)	✓	17	CLEAN CIRCUIT ELEMENTS, LOUD-SPEAKERS, TURNTABLES, REELS, MOTORS OF DIRT, DUST, GREASE, OIL, GRIME, WHERE ACCESSIBLE.  PAR 34c(9),(10),(11),(14)	✓
6	TIGHTEN - LOOSE EXTERIOR SCREWS, BOLTS, FASTENINGS, MOUNTINGS.  PAR 34b(5)	✓	18	INSPECT CAPACITORS, POTENTIOMETERS, AND RESISTORS FOR LOOSE TERMINALS, CORROSION, LEAKS, BULGES, BLISTERING, DISCOLORATION.  PAR 34c(3),(4),(5)	✗
7	INSPECT ELECTRICAL CONNECTIONS FOR FIRMNESS OF SEATING, IMPROPER CONTACT, TIGHTNESS, CORROSION, GREASE, OIL, DIRT.  PAR 34a(2)	⊕	19	<del>INSPECT ALL ELECTRICAL CONNECTIONS FOR FIRMNESS OF SEATING, IMPROPER CONTACT, TIGHTNESS, CORROSION, GREASE, OIL, DIRT.</del>	
8	INSPECT PLUGS FOR CHIPS, CRACKS, CORROSION, TARNISH, ROUGHNESS, BENDS.  PAR 34b(1)	✓	20	INSPECT ALL LABELS, ENGRAVINGS, PLATES FOR LEGIBILITY.  PAR 34c(15)	✓
9	OPERATE UNIT AND CHECK FOR SMOOTHNESS; UNUSUAL NOISES, SQUEAKS, VIBRATIONS; CORRECT OPERATION.  PAR 34b	✓	21	<del>INSPECT ALL ELECTRICAL CONNECTIONS FOR FIRMNESS OF SEATING, IMPROPER CONTACT, TIGHTNESS, CORROSION, GREASE, OIL, DIRT.</del>	
10	INSPECT ALL VISIBLE MOVING PARTS FOR BINDING, SCRAPING, SQUEAKING, EVIDENCES OF WORN BEARINGS, SHAFTS, GEARS.  PAR 34c(12)	✓	22	LUBRICATE UNIT IN ACCORDANCE WITH LATEST DEPARTMENT OF THE ARMY LUBRICATION ORDER OR INFORMATION PUBLISHED IN APPROPRIATE TECHNICAL MANUAL.  PAR 35	✓
11	INSPECT TUBE SOCKETS FOR CRACKS, CHIPS, LOOSE SOLDER CONNECTIONS.  PAR 34a(2)	✓	23	INSPECT MOISTURE AND FUNGUS PROOFING  PAR 34c(8)	✓
12	INSPECT TUBES FOR SEATING, LOOSE ENVELOPES.  PAR 34a(1)	✓	24	<del>INSPECT ALL ELECTRICAL CONNECTIONS FOR FIRMNESS OF SEATING, IMPROPER CONTACT, TIGHTNESS, CORROSION, GREASE, OIL, DIRT.</del>	
			25	INSPECT CONTROLS FOR BINDING, SCRAPING, POSITIVE ACTION.  PAR 34a(5)	✓
26 IF DEFICIENCIES NOTED ARE NOT CORRECTED DURING INSPECTION, INDICATE ACTION TAKEN FOR CORRECTION.					

DA FORM 11-251

REPLACES DA AND FORM 439, 1 DEC 50, WHICH IS OBSOLETE.

TM2503A-47

Figure 15. DA Form 11-251.

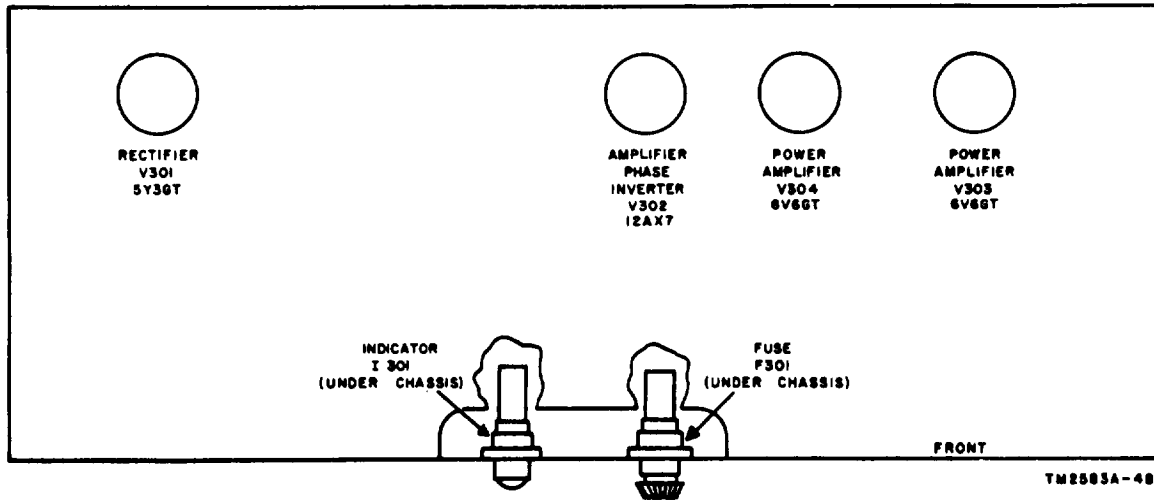

Figure 16. Tube location diagram, audio amplifier.

- (8) Check and clean the capstan and capstan roller.
- (9) Check the equipment for normal operation.

*Caution:* Disconnect all power (par. 23) from the recorder-reproducer before performing the following operations. Upon completion, reconnect power (par. 10) and check for satisfactory recording and playback operation of the equipment (par. 14 and 18).

*c. Monthly.*

- (1) Inspect all tubes (fig. 16 and 17) tube clamps, and tube shields for proper seating.
- (2) Inspect tubes for cracked envelopes. Check tube sockets for cracks and loose connections.
- (3) Inspect all potentiometers in the amplifier and audio amplifier for dirt and loose connection.

- (4) Inspect all electrolytic capacitors in all three units for leaks or bulging.
- (5) Inspect resistors for cracks, chipping, and discoloration.
- (6) Tighten the mounting bolts for all transformers in the amplifier and audio amplifier.
- (7) Inspect all transformers in the audio amplifier for evidence of overheating.
- (8) Check the moistureproof and fungiproof varnish for cracks and chipping.
- (9) Check and clean the heads in the sound head assembly.
- (10) Check the loudspeaker in the audio amplifier.
- (11) Check all soldered connections in the three chassis.
- (12) Check all motors.
- (13) Clean the fan of the capstan motor.
- (14) Check and clean all chassis connectors.
- (15) Check all name plates, panel markings, and chassis markings for legibility.

## Section IV. LUBRICATION AND WEATHERPROOFING

### 35. Lubrication

The only part of the recorder-reproducer set requiring lubrication is the capstan motor. This should be done after 1,000 hours of operation; use oil (OAI). Under severe salt-air conditions, a very light protective coating of petrolatum (PET) may be applied to the contacts of the INPUT SELECTOR SWITCH, METER SELECTOR switch, and EQUALIZATION switch (fig. 12) of the amplifier, and the function switch of the audio amplifier (fig. 13) after cleaning the contacts with Cleaning Compound. Remove Cleaning Compound residue before applying the petrolatum.

### 36. Weatherproofing

*a. General.* Signal Corps equipment, when operated under severe climatic conditions, such as prevail in tropical, arctic, and desert regions, requires special treatment and maintenance. Fungus growth, insects, dust, corrosion, salt spray, excessive moisture and extreme temperatures are harmful to most materials.

*b. Tropical Maintenance.* A special moistureproofing and fungiproofing treatment has been devised which, if properly applied, pro-

vides a reasonable degree of protection. This treatment is explained in TB SIG 13, Moistureproofing and Fungiproofing Signal Corps Equipment, and TB SIG 72, Tropical Maintenance of Ground Signal Equipment.

*c. Arctic Maintenance.* Special precautions necessary to prevent poor performance or total operational failure of equipment in extremely low temperatures are explained in TB SIG 66, Winter Maintenance of Signal Equipment and TB SIG 219, Operation of Signal Equipment at Low Temperatures.

*d. Desert Maintenance.* Special precautions necessary to prevent equipment failure in areas subject to extremely high temperatures, low humidity, and excessive sand and dust are explained in TB SIG 75, Desert Maintenance of Ground Signal Equipment.

### 37. Rustproofing and Painting

*a.* Rust and corrosion may be prevented by touching up bared surfaces. Use #000 or #0000 sandpaper to clean the surface down to the bare metal; produce a bright smooth finish.

*Caution:* Do not use steel wool; minute particles may enter the equipment and cause shorting or grounding of parts.

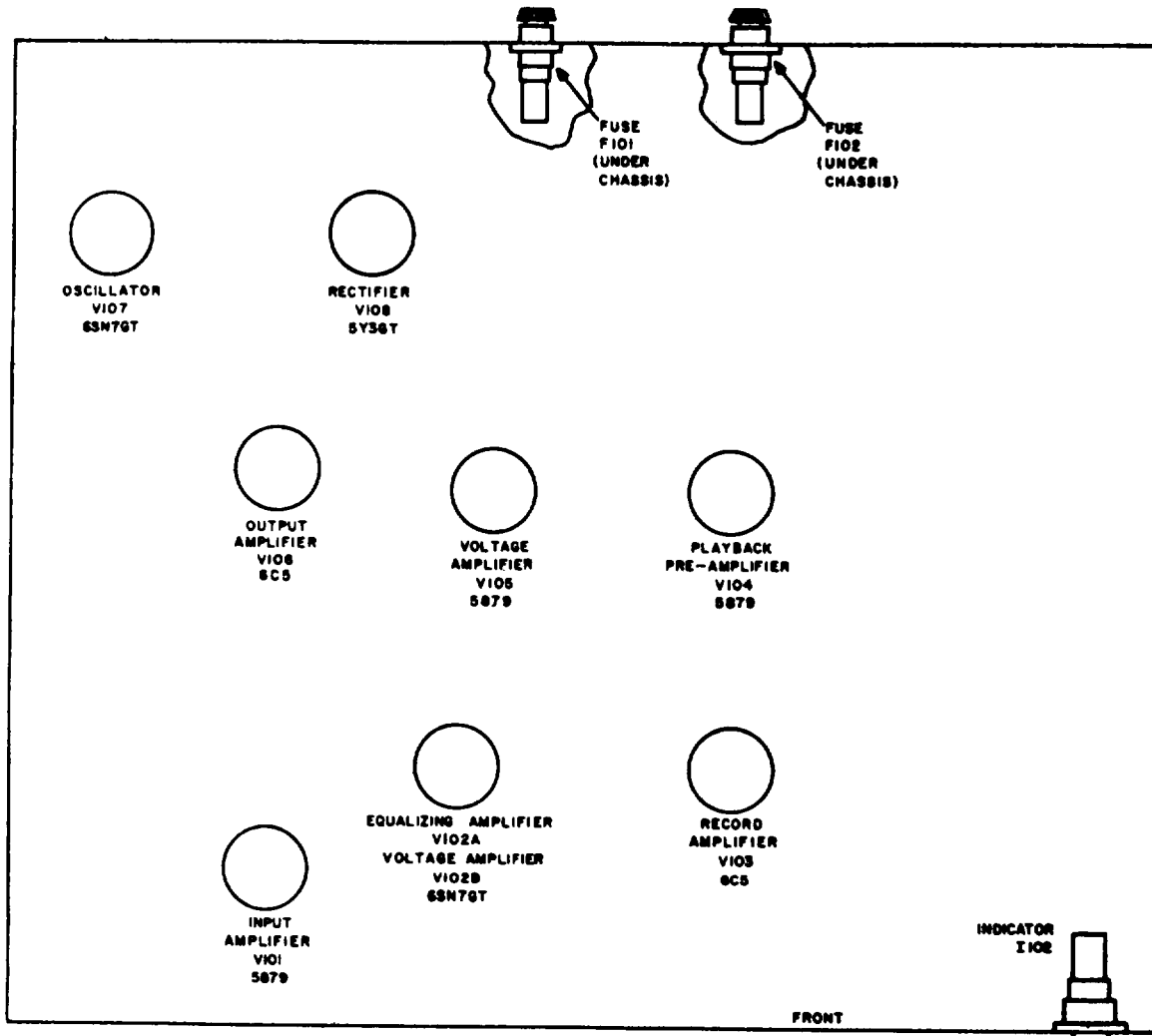

Figure 17. Tube location diagram, amplifier.



b. If a touch-up paint job becomes necessary, remove rust from the case by cleaning corroded metal with Cleaning Compound and

use sandpaper to complete the preparation of painting. Apply paint with a small brush. Use only authorized paint.

## Section V. TROUBLE SHOOTING AT ORGANIZATIONAL MAINTENANCE LEVEL

### 38. General

a. The trouble shooting and repairs that can be performed at the organizational maintenance level (operators and repairmen) are limited in scope by the tools, test equipment and replaceable parts issued. Practical trouble shooting makes use of the senses in locating such faults as burned-out fuses, broken cords, and defective tubes.

b. The paragraphs that follow in this section will help in locating the faulty circuit.

### 39. Visual Inspection

a. Failure of this equipment to operate properly is caused usually by one or more of the following faults:

- (1) Worn, broken, or disconnected cords or plugs.
- (2) Burned-out fuses.
- (3) Defective tubes.
- (4) Defective motors or tape transport mechanism.

b. If the fault is not immediately apparent, check as many of the items listed above as is practicable before starting a detailed examination of the equipment parts. If possible, obtain information from the equipment operator regarding equipment performance when trouble occurred.

### 40. Electron Tube Replacement Procedure

To avoid excessive replacement of electron tubes, follow the procedure outlined below.

a. Inspect cables, connections, and the general condition of the equipment before removing electron tubes.

b. Isolate the trouble, if possible, to a particular unit or section of the equipment.

c. If a tube tester is available, remove and test one tube at a time. Substitute new tubes only for those which are defective.

d. If a tube tester is not available, trouble shoot by the following tube substitution method:

- (1) Replace any suspected tubes, one at a time, with new tubes. Note the sockets from which the original tubes were removed. If the equipment becomes operative, discard the last tube removed.

*Note.* The erase-oscillator may function with one tube and not another, even though both tubes are new. If practicable, retain any removed tube until its condition is checked by a suitable test instrument,

- (2) Reinsert the remaining original tubes, one at a time, in the original sockets. If equipment failure occurs during this step, discard the last original tube. **DO NOT LEAVE A NEW TUBE IN A SOCKET IF THE EQUIPMENT OPERATORS SATISFACTORILY WITH THE ORIGINAL TUBE.**
- (3) If there is an insufficient number of spare tubes:
  - (a) Substitute a new tube for an original tube. Similarly, check each original tube, in turn, until the equipment becomes operative.
  - (b) Often it is possible to remove a tube from one section of the equipment without affecting the section being checked. In this case, trouble shoot the defective section using this tube as a substitute spare.

*Note.* If a replacement for a bad tube becomes defective, check the adjustment and condition of component parts of the tube circuit. Otherwise, continued tube replacement will effect only temporary re-

pair and more serious troubles may result.

e. If tube substitution does not correct the trouble, *reinsert the original tubes in the original sockets* before forwarding the defective equipment for higher echelon repair.

- (1) As a general rule, *discard* tubes when:
  - (a) A test in a tube tester or other instrument shows that the tube is defective.
  - (b) The tube defect is obvious. *For example*, the glass envelope is broken or a connecting prong or lead is broken.
- (2) Do not discard tubes merely because the tubes have been used for a specified length of time. *Satisfactory operation in a circuit is the final proof of tube quality. The tube in use may work better than a new one.*
- (3) Do not discard tubes merely because they fall on or *slightly above* the minimum acceptability value when checked in a tube tester. It must be recognized that a certain percentage of new tubes fall near the low end of the acceptability range of the tube specification and, therefore, start their operational life at a value fairly close to the tube tester *retention limit*. These tubes may provide satisfactory performance throughout a long period of operational life at the *near limit* value.
- (4) Use special care in withdrawing a miniature tube from its socket. Do not *rock* or *rotate* the top of a miniature tube when removing it from a socket; pull it straight, out. The external pin and the wire lead sealed in the glass base are two different metals which are butt-welded together where the pin appears to enter the glass. Rocking or rotating the tube bends the pins, this tends to break the weld or cause a resistance or intermittent joint to develop.

- (5) A preferred type electron tube, type 5Y3WGTA, has been developed as a direct replacement for tube type 5Y3. This tube may be used interchangeably in the amplifier and audio amplifier power supply circuits.

#### 41. Fuse Replacement

When replacing a defective fuse in either the amplifier or the audio amplifier, be sure that the correct fuse is used. Use only a 3-ampere fuse. Do not use a fuse rated higher than 3 amperes, serious damage to the equipment may occur.

#### 42. Trouble Shooting by Using Equipment Performance Check List

a. *General.* The equipment performance check list (par. 43) may help the operator to locate trouble in the equipment. The check list indicates the item to be checked, the conditions under which the item is to be checked, the normal indications and tolerances of correct operation, and the corrective measures the operator can take. *To use this list effectively, follow the items in numerical sequence.*

b. *Action or Condition.* For some items, the information given in the *Action or condition* column consists of various switch and control check settings which are made when the item is checked. For other items, it represents an action that must be taken to produce the normal indication given in the *Normal indications* column.

c. *Normal Indications.* The normal indications listed are the visible and audible signs that the operator should observe after applying the information given in the *Action or condition* column. If the indications are not normal, the operator should apply the recommended corrective measures.

d. *Corrective Measures.* Most of the corrective measures listed are those within the scope of the operator. If the trouble cannot be corrected by the operator, trouble shooting by an experienced repairman is necessary. However, if the tactical situation requires that the equipment be maintained, the operator must keep the set in operation as long as possible.

### 43. Equipment Performance Check List

#### a. Recording.

	Item No.	Item	Action or condition	Normal Indications	Corrective measures	
P R E P A R A T O R Y	1	Cable (microphone, inter-connecting and power).	Connect all components.	Connectors fit securely.	Apply proper pressure on connectors.	
	2	Function switch, audio amplifier.	Operate to the PHONES position.			
	3	MONITOR LEVEL control.	Turn to a setting of 8.			
	4	RECORD LEVEL control.	Turn to a setting of 5.			
	5	INPUT SELECTOR switch.	Move to the MIC position.			
	6	METER SELECTOR switch.	Move to the RECORD LEVEL position.			
	7	EQUALIZATION switch.	Move to the 15 I.P.S. position.			
	8	Headset.	Connect to the EAR-PHONES jack.			
	9	Supply reel.	Install the supply reel and adapter.			
	10	Take-up reel.	Install the take-up reel.			
	11	Tape gate.	Open the gate.			
	12	Recording tape.	Thread the tape.			Tape tension closes automatic safety switch S202.
	13	LINE TERMINATION switch.	Move to the OFF position.			
	14	Tape gate.	Close the gate.			
	15	7 ½ -15" switch.	Operate to the 15" position.			
S T A R T	16	Soundhead assembly.	Check tape.	Tape fits correctly in the soundhead assembly.	Turn the take-up reel to take up any slack in the tape.	
	17	ON-OFF switch.	Operate to the ON position.	Pilot lamps light, filaments of the tubes light.	Check the power cable and connections. Check the fuses (par. 41). Check the pilot lamp. Check the tubes (par. 40). Check the ON-OFF switch. Replace the defective fuses, tubes, and pilot lamps.	

Item No.	Item	Action or condition	Normal indications	Corrective measures
18	RECORD switch.	Press the switch.	RECORD INDICATOR lamp glows.	Check the switch. Check the lamp and replace if defective.
19	PLAY switch.	Press the switch.	Tape moves from left to right (as viewed from front panel).	Check all connections. Check the switch. Check the tape threading (par. 13). Check the gate.
20	RECORD LEVEL control, vu meter.	Talk into the microphone and adjust the RECORD LEVEL control.	Vu meter indicates 100 on loud sounds. Sound is heard in the headset.	Check the microphone, cable and connector. Check the meter. Check the RECORD LEVEL control. Check the headset and cable.
21	METER SELECTOR switch.	While talking into the microphone, operate the METER SELECTOR switch to the PLAYBACK LEVEL position.	Recorded voice is heard in the headset by the monitor.	Check the switch.
22	Headset.	Connect to the PHONES jack.	Recorded tape is heard in the headset.	Check the headset. Check the cables. Check the PHONES jack.
23	PLAYBACK LEVEL control.	While listening to the recorded sound, adjust the PLAYBACK LEVEL control.	Vu meter indicates 100 on peak of sound.	Check the PLAYBACK LEVEL control.
24	METER SELECTOR switch.	While talking into the microphone, operate the METER SELECTOR switch to the BIAS position.	Vu meter indicates 100, approximately.	Turn in equipment for bias adjustment.
25	METER SELECTOR switch.	While talking into the microphone, operate the METER SELECTOR switch to the ERASE position,	Vu meter indicates 100, approximately.	Turn in equipment for erase adjustment.
26	STOP switch.	Press the switch.	Tape movement stops RECORD indicator is extinguished.	Check the switch. Check the RECORD indicator,
27	Tape gate.	Open the gate.	Tape is removed from the contact with the sound head.	Check the gate.

EQUIPMENT PERFORMANCE

	Item No.	Item	Normal Indications	Action or condition	Corrective measures
S T O P	28	WIND switch.	Press the switch.	Tape winds quickly.	Check the switch. Check the relays.
	29	STOP switch.	Press the switch.	Tape movement stops.	Check the switch. Check the relays.
	30	REWIND switch.	Press the switch,	Tape rewinds quickly.	Check the switch. Check the relays.
	31	STOP switch.	Press the switch.	Tape movement stops.	Check the switch.
	32	ON-OFF switch.	Move to the OFF position.	All pilot lights are extinguished. All motors stop.	

*b. Playback.*

	Item No.	Item	Action or condition	Normal indications	Corrective measures
P R E P A R A T O R Y	1	Cables, interconnecting and power.	Connect to proper connectors.	Connectors fit properly.	Apply proper pressure.
	2	Function switch, audio amplifier.	Move to the PHONES position.		
	3	PLAYBACK LEVEL control.	Turn to the 5 position.		
	4	METER SELECTOR switch.	Move to the PLAYBACK LEVEL position.		
	5	LINE TERMINATION switch.	Move to the OFF position.		
	6	Headset.	Connect to the EAR-PHONES jack.		
	7	Supply reel.	Install a reel of recorded tape.		
	8	Take-up reel.	Install the reel.		
	9	Tape.	Open the gate, thread the tape, close the gate.		
E Q U I P M E N T P E R F O R M A N C E	10	ON-OFF switch.	Operate to the ON position.	Pilot lamps light, filaments of the tubes glow.	Check the cables. Check the fuses. (par. 41)
	11	PLAY switch.	Press the switch.	Tape moves from supply reel. Sound is heard in the headset.	Check the tape transport mechanism. Check the headset, Check the jack.
	12	PLAYBACK LEVEL control; vu meter.	Listen to playback, adjust PLAYBACK LEVEL control.	Meter indicates 100 on signal peaks.	Check the connection Check the meter. Check the control.
	13	Headset.	Connect to the PHONES jack.	Playback is heard in the headset.	Check the connector
	14	Function switch audio amplifier.	Turn to the SPEAKER PHONES position.	Sound is heard in the loudspeaker,	Check the loudspeaker
	15	External loudspeaker.	Connect to the EXTERNAL SPEAKER jack.	Sound is heard in the external loudspeaker.	Check the loudspeaker
S T O P	16	Same as items 31 and 32 in a above.			

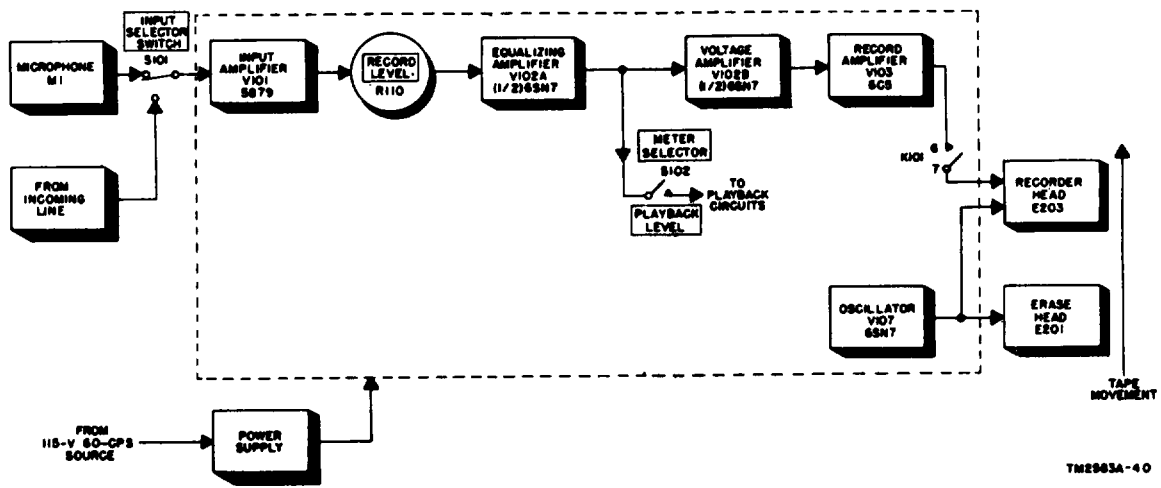

Figure 18. Block diagram of recording circuit.

## CHAPTER 5

### THEORY

---

#### 44. General

The recorder-reproducer set has the following major interrelated components; recorder-reproducer, amplifier, and audio amplifier (fig. 48, 49, and 50).

*a. Recorder-reproducer.* The recorder-reproducer drive system consists of a two-speed capstan motor (B202), a take-up reel motor (B201), and a supply-reel motor (B203). The sound head assembly consists of the erase head (E203), the recorder head (E202), and the reproducer head (E201). A half-wave power supply circuit consists of a selenium rectifier (CR201) and a filter capacitor (C203). The power supply delivers direct-current (dc) voltage for energizing relays K201, K202, and K203, solenoids L201, L202, and L203 of the recorder-reproducer, and K101 of the amplifier.

*b. Amplifier.* The amplifier consists basically of a power supply circuit, a recording amplifier circuit, a playback amplifier circuit, an erase-oscillator circuit, and the volume level (vu) meter circuit.

- (1) *Power supply circuit.* The power supply consists of full-wave rectifier V108 ( 5Y3GT) and a filter circuit. The power supply delivers dc voltage for the B+ and screen circuits and ac and dc filament voltages for the tubes in the amplifier and erase-oscillator circuits. (Filaments of tubes V101, 104, and V105 are dc fed to minimize hum pick-up. )
- (2) *Recording amplifier circuit.* The recording amplifier consists of four resistance-coupled amplifier stages, tube V101 (5879 pentode tube), tube V102A (one-half of dual triode

6SN7), tube V102B (the other half), tube V103 (6C5 triode tube), and an equalizer circuit consisting of a resistance-capacitance network to correct the frequency response of the amplifier. The output of the recording amplifier is connected to the recorder head in the amplifier group.

- (3) *Playback amplifier circuit.* The playback amplifier consists of three resistance-coupled amplifier stages, tubes V104 and V105 (5879 pentode tubes) and tube V106 (6C5 triode tube). The output of the playback amplifier is fed to OUTPUT connector P102, EARPHONES connector J104, and MONITOR connector J105.
- (4) *Erase-oscillator circuit.* The erase-oscillator circuit is a 65-kilocycle (kc) oscillator that consists of tube V107 (6SN7 dual triode) and a tuned tank circuit. The oscillator voltage erases unwanted recordings and provides a high frequency magnetic bias that improves the quality of the recording.
- (5) *Volume level (vu) meter circuit.* Volume level meter M101 is connected across the output terminals of the playback amplifier. Meter M101 indicates the level of sound during recording and playback operation. The meter is used also to indicate bias and erase currents.

*c. Audio Amplifier.* The audio amplifier consists of a power supply circuit, a voltage amplifier-phase inverter circuit, a push-pull power-amplifier circuit, and a loudspeaker. The audio amplifier is used for monitoring and for public address set operation.

- (1) *Power supply circuit.* The power supply circuit consists of full-wave rectifier tube V301 (5Y3GT) and a filter circuit. The power supply delivers dc voltages for the B+ and screen circuits and ac voltages for the filaments of the tubes in the audio amplifier.
- (2) *Voltage amplifier-phase inverter circuit.* The voltage amplifier-phase inverter circuit consists of tube V302 (12AX7 dual triode). The tube delivers signal voltage for the push-pull power-amplifier stages.
- (3) *Push-pull power-amplifier circuit.* The power-amplifier circuit consists of tubes V303 and V304 (6V6GT pentode) connected in push-pull. The tubes deliver audio power to the loud-speaker.

#### 45. Recording Block Diagram (fig. 18)

a. The signal paths through the sound recorder-reproducer set with the equipment operating as a recorder are as follows:

- (1) The input signal from either the microphone or the incoming line is fed into input amplifier tube V101 through the contacts of INPUT SELECTOR SWITCH S101, which is used to select the correct circuit for the type input signal supplied.
- (2) The amplified output of tube V101 is fed to amplifier tube V102A through RECORD LEVEL control R110 which is used to control the level of the signal fed to tube V102A.
- (3) The amplified signal is fed through the equalization circuit to amplifier tube V102B, amplified again, and then fed to recording amplifier tube V103.
- (4) The output of tube V103 is connected to the recorder head in the sound head assembly through contacts 6 and 7 of record relay K101.
- (5) During the recording, the output of erase-oscillator tube V107 is fed through an interconnecting cable to erase head E201 in the sound head assembly.

b. For monitoring purposes, a portion of the recording amplifier is fed to, and amplified by, the playback amplifier as follows:

- (1) A portion of the output signal of tube V102A is fed to voltage amplifier tube V105 through the contacts of METER SELECTOR switch S102.
- (2) The amplified output of tube V105 (fig. 19) is fed to output amplifier tube V106, and then to OUTPUT connector P102, EARPHONES jack J104, and MONITOR jack J105 (fig. 19).
- (3) A portion of the output of tube V106 is fed back to the cathode of tube V105 as a negative feed-back voltage.
- (4) Tube V105 output is connected through METER SELECTOR switch S102 to EARPHONES jack J104, to OUTPUT connector P102, or to the audio amplifier through a connection to MONITOR jack J105.
- (5) LINE TERMINATION switch S106 is used to close a circuit to load the playback amplifier output when using a headset with other than a 600-ohm impedance or when the audio amplifier is not connected to the amplifier.

#### 46. Playback Block Diagram (fig. 19)

The signal paths with the equipment operated as a reproducer, are as follows:

a. The recorded signal from the reproducer head in the sound head assembly is fed into playback pre-amplifier tube V104.

b. The output of tube V104 is fed to tube V105 through an equalization circuit and through the PLAYBACK LEVEL control, which regulates the strength of the signal fed into voltage amplifier tube V105.

c. The signal then follows the same path described in paragraph 45b. In this mode of operation, the volume level (vu) meter is connected across the output of tube V106 to indicate the level of sound being played back.

#### 47. Audio Amplifier, Block Diagram (fig. 20)

The signal paths, with the audio amplifier connected to the output of V106 for monitoring purposes, are as follows:

a. The signals from OUTPUT connector P102 are fed to amplifier phase-inverter tube V302 through MONITOR INPUT connector J303.



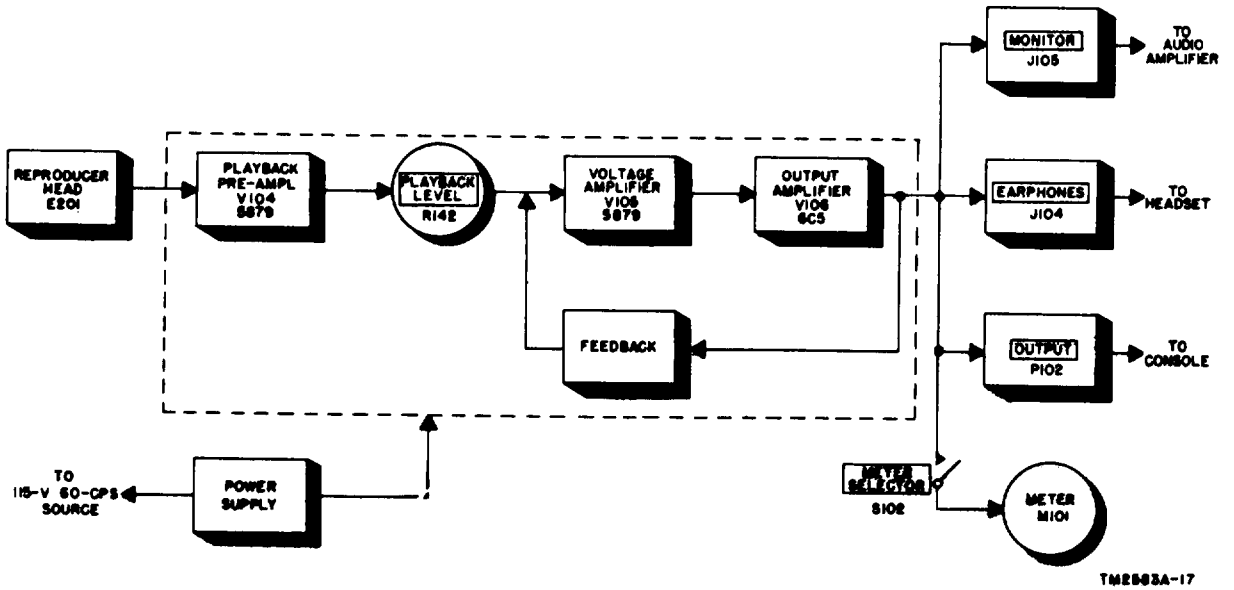

Figure 19. Block diagram of playback circuit.

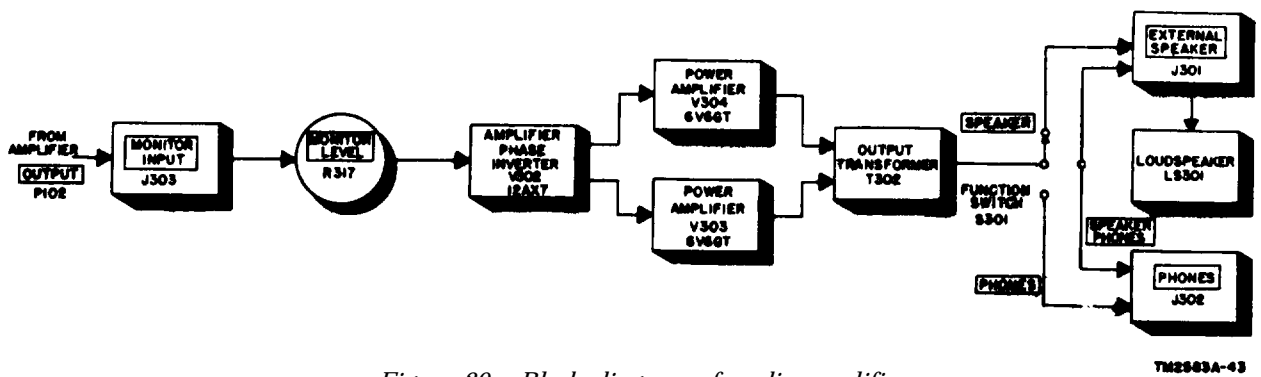

Figure 20. Block diagram of audio amplifier.

b. The signal is amplified and inverted in phase.

c. The amplified and phase-inverted signals are applied to push-pull, power-amplifier tubes V303 and V304.

d. The output of the audio amplifier is fed through function switch S301 to internal loudspeaker LS301 (or to an external loudspeaker through connection to EXTERNAL SPEAKER jack J301) or to a headset through connection to PHONES jack J302. Connection of an external speaker in EXTERNAL SPEAKER jack J301 disconnects the internal loudspeaker.

e. A portion of the output is fed back to the cathode of tube V302 as a negative feed-back voltage.

#### 48. Recorder-reproducer (fig. 36 and 37)

The recorder-reproducer contains the tape-transport mechanism, necessary tape-transport controls, the soundhead assembly, and a power supply circuit.

a. *Tape-transport Mechanism.* The tape-transport mechanism consists of two-speed capstan motor B202 and tape drive assembly, supply-reel motor B203, take-up reel motor B201, and the necessary tape guides, brakes, solenoids, and relays.

b. *Controls.* The controls consist of ON-OFF switch S203, STOP switch S201, PLAY switch S206, REWIND switch S207, WIND switch S205, 7½"-15" switch S204, and automatic shut-off arm switch S202.

c. *Soundhead Assembly.* The soundhead assembly contains the erase head, the recorder head, the reproducer head, the tape guides, and connector P204.

d. *Power Supply.* The power supply circuit consists of a selenium rectifier and a filter circuit which supplies dc voltage for operating the relays, the brakes, and the solenoids.

#### 49. Recording or Playback Circuit (fig. 49 and 50)

a. With the tape threaded properly and the equipment for recording (par. 14) or playback (par. 18), 115 volts ac is connected to the windings of all motors and to the input of the recorder-reproducer power supply. Resistor R202 is connected in series with the windings of take-up motor B201 through contacts of relay K201. Resistor R203 is connected in

series with the winding of supply motor B203, also through contacts of relay K201. The circuit of two-speed capstan motor B202 is closed through the contacts of 7½"-15" switch S204. Capacitors C201, C202, and C204 are motor start capacitors used to provide adequate motor starting torque.

b. With PLAY switch S206 closed, the dc circuit to the winding of relay K201 is closed through contacts 3 and 4 of relay K202. Relay K201 closes and completes the ac circuit to supply motor B203 through contacts 5 and 4 of relay K201, and through R203. The action also completes the ac circuit to take-up motor B201 through contacts 12 and 9 of relay K201 and tapped resistor R202. Resistors R202 and R203 reduce the voltage to the windings of the motors to reduce the starting torque.

c. Solenoids L201 and L203 of brakes O 201 and O 203 respectively are connected to one side of the dc circuit through the closed contacts of automatic safety switch S202 and push-to-open STOP switch S201. The dc circuit is closed through contacts 6 and 7 of relay K201. Solenoid L202 of drive roller O 202 is connected to the low side of the dc circuit and the circuit is closed through contacts 11 and 2 of relay K201 and contacts 3 and 4 of relay K202. With the brake solenoids energized, the brakes are released and the motors are free to rotate. With drive roller solenoid L202 energized, the pressure roller assembly is engaged and presses the tape between the pressure roller and the tape capstan drive.

d. The action of the capstan drive and the pressure roller feeds the tape from the supply reel onto the take-up reel. Supply motor B203 drives the supply-reel spindle and develops enough drag on the tape to provide the correct tensioning of tape against the automatic switch arm (of switch S202); the take-up motor drives the take-up reel spindle to prevent tape spilling.

e. During recording, the tape is pulled past the erase head, the recorder head, and the reproducer head in successive order. Information, previously recorded on the tape, is erased by the magnetic field of the erase head.

f. The power supply circuit consists of selenium rectifier CR201, limiting resistor R201, and filter capacitor C203. The ac input (115 volts) is rectified by CR201 and filtered

by R201 and C203. The output voltage of the power supply is 115 volts dc with full load.

#### 50. Fast Rewinding Circuit (fig. 50)

a. With the tape threaded properly and the equipment operated for rewinding (par. 19), 115 volts ac is connected to the winding of supply motor B203 and to the input of the recorder-reproducer power supply. Solenoids L201 and L203 of brakes O 201 and O 203 are energized and the brakes are released, Solenoid L202 of drive roller O 202 is not energized and the pressure roller therefore is not pressed against the tape capstan drive thus releasing the tape metering action. Supply motor B203 rapidly rewinds the tape onto the supply reel.

b. One side of the 115-volt ac line is connected to the input of the selenium rectifier, and the other side of the line is connected to the low side of the rectifier circuit. The 115-volt dc output of the rectifier is connected to the coil of relay K202 through contacts of safety switch S202, STOP switch S201, and REWIND switch S207. The circuit, when closed through contacts 8 and 7 of relay K201, energizes relay K202 and applies 115 volts dc to the coil of relay K201 through holding contacts 9 and 12 of relay K202.

c. Ac power is now connected to the winding of supply motor B203, through contacts 3 and 4 of K203 and 4 and 5 of relay K202.

d. Solenoids L201 and L203 of brake O 201 and O 203 are connected to the 115-volt dc output of the rectifier and the circuit is completed through contacts 11, 2, and 4 of K202.

#### 51. Fast Winding Circuit (fig. 50)

a. With the tape threaded properly and the equipment operated for fast wind operation (par. 20), 115 volts ac is connected to the winding of take-up motor B201 and to the input of the selenium power supply. Relays K203 and K202 and solenoids L201 and L203 of brakes O 201 and O 203 are therefore energized with dc; solenoid L202 of O 202 is not energized however. Take-up motor B201 rapidly rewinds the tape onto the take-up reel.

b. The output of the rectifier is connected to the coil of relay K203 through automatic safety switch S202, STOP switch S201, closed contacts 8 and 7 of relay K202, and WIND

switch S205. The circuit is completed through contacts 8 and 7 of K201, thus energizing relay K203. This applies 115 volts dc to the coil of relay K203 through holding contacts 9 and 12 of relay K203. With relay K203 energized, 115 volts dc is also applied to the coil of relay K202 through contacts 7 and 6 of relay K203. The circuit to the coil of relay K202 is closed through contacts 8 and 7 of relay K202, energizing the relay. With relay K202 energized, 115 volts dc is applied to holding contacts 9 and 12 of relay K202.

c. Ac power is connected to take-up motor B201 through the contacts of ON-OFF switch S203 and capacitor C201. The circuit is completed through contacts 5 and 4 of relay K203 and contacts 5 and 4 of relay K202.

d. Solenoids L201 and L203 of brake O 201 and O 203 are connected to the 115-volt dc output of the rectifier and the circuit is completed through contacts 11, 2, and 4 of relay K202.

#### 52. Recording Input Circuit

a. *Microphone* (fig. 21). With the microphone connected to INPUT connector P101, and INPUT SELECTOR SWITCH S101 operated to the MIC. position, incoming signals from the microphone are connected across the primary of transformer T101 through contacts 8 and 9 of the rear section of switch S101, and 8 and 6 of the front section of switch S101. Signal information is induced into the secondary of transformer T101 and then to pin 1 (control grid) of tube V101. Resistor R160 provides a low-impedance path to ground to reduce hum level.

b. *Bridging input* (fig. 22). A bridging input circuit is a high-impedance circuit connected across a program line. The high impedance is used to prevent excessive loading of the line. The incoming signal at INPUT connector P101 is connected across a balanced input circuit consisting of resistors R102 and R103, through contacts 8 and 10 of the rear section, and 6 and 9 of the front section of switch S101. The signal from the program line is applied to the primary of T101 from the junction of voltage divider resistors R101 and R160, and the circuit is closed from transformer T101 to the junction of voltage divider resistors R104 and R159, through contacts 2 and 3 of the rear section of switch S101.

Resistors R159 and R160 are also used to provide the correct impedance loading for the primary of transformer T101.

c. *Balanced Input* (fig. 23). With INPUT SELECTOR SWITCH S101 in the 600 BAL. position and a signal source connected to INPUT connector P101, the input circuit is similar to that for bridging, except that resistors R105 and R106 are connected across the input. The junction of the resistors is grounded through contacts 2 and 3 of the front section of switch S101.

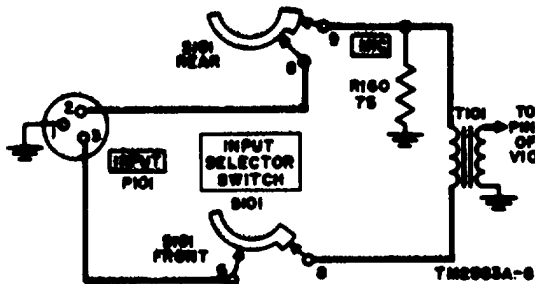

Figure 21. Microphone input circuit, simplified schematic diagram.

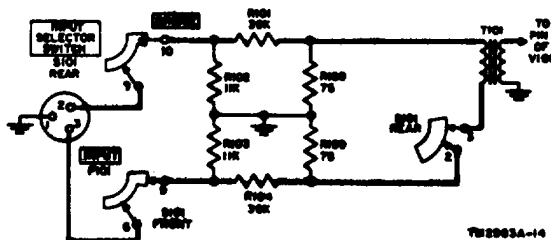

Figure 22. Bridging input circuit, simplified schematic diagram.

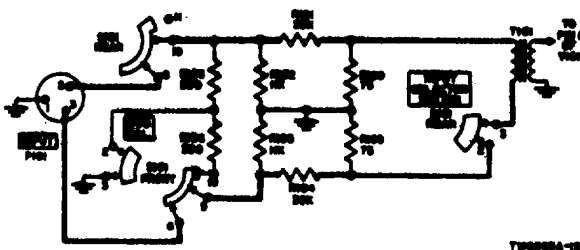

Figure 23. Balanced input circuit, simplified schematic diagram.

d. *Unbalanced Input*. This circuit is the same as the circuit for balanced input except that the ground connection at the junction of R105 and R106 is removed.

### 53. Recording Amplifier and Erase-oscillator circuit (fig. 24 and 49)

a. *General*. The input signal to the amplifier is taken from the microphone input, the telephone, or a program line. The signal is amplified successively by input amplifier tube V101, equalizing amplifier tube V102A, voltage amplifier tube V102B, and recording amplifier tube V103. The output of the recording amplifier is fed to the recorder head in the sound head assembly. The erase-oscillator output is connected to the erase head in the sound head assembly.

b. *Input Amplifier V101*. The input signal developed across the secondary of transformer T101 is fed to the control grid of tube V101, and the amplified output developed across plate load resistor R108 is coupled out to tube V102A control grid through capacitor C103. Plate voltage for tube V101 is taken from the junction of resistor R161 and capacitor C120C and dropped by resistors R163 and R108. Resistor R163 and capacitor C104A form a decoupling filter and prevent the ac output of tube V101 from reaching the power supply circuit. Screen voltage for tube V101 is taken from the junction of resistors R163 and R108 and applied to the screen through voltage dropping resistor R109. Capacitor C102 is a screen bypass capacitor. Cathode bias is developed across resistor R107, and maintained at a constant level by capacitor C101.

c. *Equalizing Amplifier V102A*. The output signal of tube V101 smears across RECORD LEVEL control R110 and a portion of the signal is fed to the control grid of V102A, which is connected to the center arm of the RECORD LEVEL control. The amplified signal output across plate load resistor R112 is coupled out to tube V102B control grid through capacitor C106. Plate voltage for tube V102A is taken from the junction of resistors R158 and R137. Resistor R158 and capacitor C104C form a decoupling filter and decouple the output of V102A from the power supply circuit. Cathode bias is developed across cathode resistor R111 and filtered by capacitor C105.

*d. Equalization Circuits.* The equalization circuit provides a high frequency boost or a low frequency boost for recorded signals, during either 7½-ips or 15-ips operation. With EQUALIZATION SWITCH S103 in the 15 I.P.S. position, the output signal of tube V102A is coupled out by capacitor C106 to the equalization circuit and developed across resistors R114 and R115 in series. At the junction of capacitor C106 and resistor R114, the signal is fed to resistors R113, R123, and R116 in series. Variable capacitor C107, in shunt with resistor R113, provides a virtual short circuit around resistor R113 for the high frequency signals. Capacitor C128 in shunt with resistor R116 provides a low-impedance path for frequencies above 100 cps. With EQUALIZATION SWITCH S103 in the 7½ I.P.S. position, capacitors C108 and C135 are connected in shunt with capacitor C107 to lower the impedance and provide additional high frequency boost.

*e. Voltage Amplifier V102B.* The input signal to tube V102B is taken from the junction of resistors R123 and R113 and fed to the control grid of the tube. The amplified output across plate load resistor R118 is coupled out to tube V103 control grid through capacitor C110. Plate voltage for tube V102B is taken from the same circuit as that for the plate voltage for tube V120A (c above) and applied to tube V102B through plate load resistor R118. Cathode bias is developed across resistor R117 and filtered by capacitor C109. A portion of the recorded signal is taken from the center arm of resistor R115 and fed through contacts 3 and 1 of section 2 of METER SELECTOR switch S102 and to the input of tube V105 in the playback amplifier.

*f. Recording Amplifier V103.* The output signal of tube V102B appears across resistor R119 and is fed to the control grid of tube V103. The amplified output across plate load resistor R122 is coupled to connector J102 through capacitor C113 and contacts 6 and 7 of record relay K101 (*g* below). Plate voltage for tube V103 is taken from the junction of resistors R158 and R161 (*b* above) and applied through plate load resistor R122. Cathode bias and negative feed-back voltage are developed across resistor R120. Tube V103 cathode and control grid are returned to an equalization

circuit consisting of coil L102, resistor R121, and capacitors C112 and C111. The equalization circuit provides additional negative feedback for the cathode of tube V103 and reduces the gain of the tube at the lower frequencies. For 15-ips operation, equalization is provided by the series resonant circuit consisting of coil L102 and capacitor C112. For 7½-ips operation, capacitor C111 is connected across C112 to lower the frequency at which the equalization action starts.

*g. Record Relay K101.* Record relay K101 is operated by pressing RECORD switch S105. This applies 115 volts dc to the winding of the coil and closes the relay. Contacts 12 and 9 close and short RECORD switch S105 thereby holding the relay closed. High voltage from the junction of resistor R161 and choke coil L101 is applied to the plate circuit of erase-oscillator tube V107 and to RECORD INDICATOR lamp I 101 through contacts 4 and 5 of relay K101. Lamp I 101 is illuminated and tube V107 oscillates. With relay K101 energized, the output of recording amplifier tube V103 is connected to connector J102 through contacts 6 and 7 of relay K101. With relay K101 de-energized the plate circuit of the oscillator is open, and the oscillator tube stops oscillating.

*h. Erase-oscillator V107* (fig. 24). The 65-kc push-pull oscillator supplies recording bias and erase currents to the recorder and erase heads of the soundhead assembly. The amount of erase current (fed through connector J103) is determined by the setting of capacitor C115. The level of recording bias (fed through connector J102) is determined by the setting of resistor R125 and capacitor C114. The frequency of oscillation is determined by the tank circuit consisting of capacitor C131 and the primary of oscillator transformer T104. With plate voltage applied through the primary of transformer T104 and contacts 4 and 5 of relay K101, tube V107A conducts, and voltages of the resonant frequency (65 kc) of the tank are developed and fed to the control grid of tube V107B through capacitor C132. Tube V107B conducts and voltages of the resonant frequency of the tank are coupled to the control grid of tube V107A through capacitor C133. The capacitor coupled feed-back voltage maintains the oscillations in both tubes. At the positive peaks of the feed-back voltage to the con-

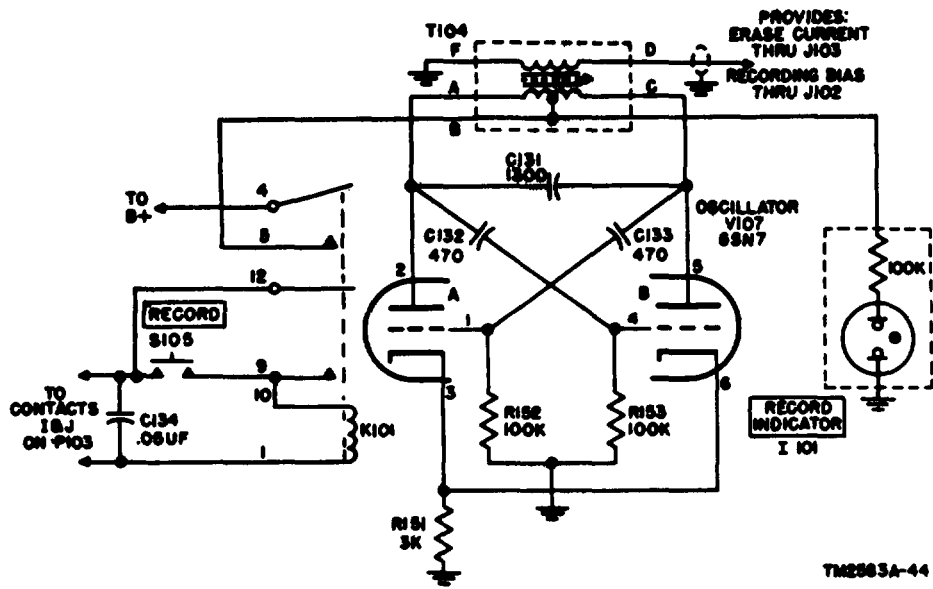

Figure 24. Erase-oscillator circuit, simplified schematic diagram.

trol grid of tube V107A, grid current flows and charges capacitor C133. The discharge of capacitor C133 through resistor R152 develops a grid bias which blocks tube V107A. At the following positive peak, the cycle is repeated. In a similar manner, grid bias for tube V107B is developed across resistor R153. Cathode bias for both tubes is developed across cathode resistor R151. Because a negative feed-back voltage is developed across resistor R151, distortion of the generated signal is reduced.

*i. Noise Balance Circuit* (fig. 25). The noise balance circuit cancels out the effects of residual magnetic bias in the recorder head and thus lowers the noise level of the recorded information. A small dc voltage, impressed across the circuit, improves the linearity of the recorded signal by suppressing the third harmonic distortion. The circuit consists of resistors R128 and R129 and capacitor C116 as one side, and resistors R127 and R124 as the other side. Because positive voltages of differing magnitudes are applied across the recorder head, a current will flow through the recorder head to cancel the effects of any residual magnetic bias. Resistor R129 is used to set the level and polarity of current through the recorder head.

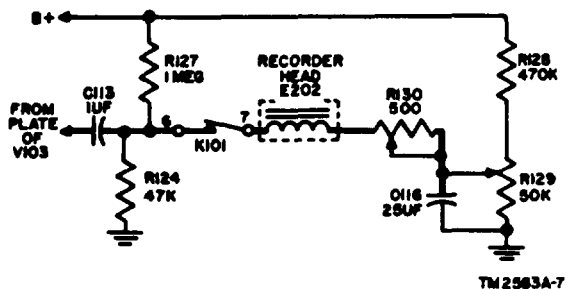

Figure 25. Noise balance circuit, simplified schematic diagram.

#### 54. Playback Circuit (fig 49 and 51)

*a. General.* The input signal to the playback amplifier is taken from the reproducer head of the sound head assembly. The signal is amplified successively by playback preamplifier tube V104, voltage amplifier tube V105, and output amplifier tube V106. The output of tube V106 is connected to MONITOR jack J105, to OUTPUT connector P102, and to EAR-

PHONES jack J104. The output signal may be connected to the audio amplifier for public address operation.

*b. Playback Preamplifier V104.* The output of the reproducer head is fed across resistor R132 to the control grid of tube V104 through connector J101. The amplified output across plate load resistor R136 is coupled out through capacitor C121. Plate voltage for the tube is taken from the junction of resistor R158 and capacitor C104C. Resistor R137 and capacitor C104B form a decoupling filter and decouple the ac in the output of tube V104 from reaching the power supply circuit. Screen voltage is taken from the junction of voltage divider resistors R137 and R135 connected across the power supply circuit. The screen voltage is dropped by resistor R134 and filtered by capacitor C118. Cathode bias is developed across resistor R133 and maintained at a constant level by capacitor C117.

*c. Playback Equalization Circuit.*

- (1) The equalization circuit provides low frequency boost for playback signals. Capacitor C122 provides a low-impedance path for frequencies above 8 kc around resistors R139 and R141. Capacitor C123 and resistor R140 presents a high impedance to low frequency signals and a low impedance to high frequencies.
- (2) The output of the equalization circuit appears across PLAYBACK LEVEL control R142, and a portion of the playback signal is fed to the control grid of tube V105 through contacts 1 and 12 of section 2 of METER SELECTOR switch S102 when switch S102 is in the PLAYBACK LEVEL position. The amplified output across plate load resistor R146 is coupled out to tube V106 through capacitor C127. Plate voltage for tube V105 is taken from the junction of resistor R158 and capacitor C104C and dropped by resistor R146. Screen voltage, taken from the same point, is dropped by resistor R145 and filtered by capacitor C126. Cathode bias voltage is developed across resistors R143 and R144 and filtered by capacitor C124. Negative feed-back voltage

taken from the output. of tube V106 (*d* below) is fed through filter resistor R131 and developed across R144. Capacitor C125 reduces the feed-back voltage at the higher frequencies to improve the frequency response of the stage.

*d. Output Amplifier V106.* The output signal of tube V105 is fed to the control grid of tube V106 across grid loading resistor R147. The amplified output across the secondary of transformer T102 is fed to OUTPUT connector P102 or EARPHONES jack J104. The amplified output at the primary of T102 is coupled out to MONITOR jack J105 through resistor R149 and capacitor C130. Plate voltage for tube V106 is taken from the junction of resistor R161 and capacitor C120C and applied through the primary of T102. Cathode bias is developed across resistor R148 and filtered by capacitor C129. To compensate for an output load of other than 600 ohms connected to either connector J104 or connector P102, LINE TERMINATION switch S104, when *thrown to the ON* position, places resistor R150 across the secondary of transformer T102 to provide a proper substitute load.

#### 55. Meter Circuit (fig. 49)

*a. General.* Meter M101 is used to indicate the level of playback and recorded signals, and also to indicate the levels of the bias and erase currents applied to the recorder head and erase head. Section 1 of METER SELECTOR switch S102 is used to connect the meter into the appropriate circuit; section 2 is used to close circuits for monitoring purposes.

*b. PLAYBACK LEVEL.* With METER SELECTOR switch S102 in the PLAYBACK LEVEL position, meter M101 is connected across the secondary of transformer T102 through contacts 8 and 7 and 1 and 2 of section 1 of S102. Resistor R138, connected in series with meter M101, converts the measurement to volume units (vu). Playback circuit is completed in section 2 of switch S102 and playback can be monitored.

*c. RECORD LEVEL.* With METER SELECTOR switch S102 in the RECORD LEVEL position, the circuit to meter M101 is the same as that used for playback except that contact 3 replaces contact 2, and contact 9 replaces

contact 8. Contacts 1 and 3 of section 2 make, And recorded signals can be monitored by using the meter indication and/or the headset (or loudspeaker).

*d. BIAS.* With METER SELECTOR switch S102 in the BIAS position, and the erase-oscillator circuit operative, meter M101 is connected across resistor R130 in series with the recorder coil. The circuit to the meter is closed through contacts 1 and 4 and 7 and 10 of section 1 of switch S102. Section 2 of switch S102 is open. Recorded signals can be monitored only by using the headset or loudspeaker or both.

*e. ERASE.* With METER SELECTOR switch S102 in the ERASE position and the erase-oscillator circuit operative, meter M101 is connected to measure the voltage drop across resistor R126 which is connected in series with the erase coil, thus measuring the output of erase-oscillator tube V107. Recorded signals can be monitored through use of the headset or loudspeaker or both.

#### 56. Amplifier Power Supply (fig. 49)

*a.* The amplifier power supply circuit supplies dc plate and screen voltages for the amplifier tubes and the erase-oscillator; also supplied are ac and dc filament voltages and ac for pilot lamp I 101.

*b.* The 115-volt ac 60-cps line is connected to the primary of power transformer T103 through fuse F102. The stepped up voltage across the secondary of transformer T103 is connected to the plates of full-wave rectifier tube V108. The rectified output of tube V108 is filtered by capacitor C120A, C120B, and C120C, choke L101, and resistor R161.

*c.* Ac filament voltage for tubes V102A, V102B, and V103 is taken from the 6.3-volt secondary winding of power transformer T103. The same winding provides ac voltage for pilot lamp I 101,

*d.* Dc filament voltage for tube V101 is taken from the output of selenium rectifier CR101. Stepped down voltage from the secondary of transformer T103 is connected to full-wave rectifier CR101. The rectified output of CR101 is filtered by dropping and surge-limiting resistor R155 and capacitor C119. Resistors R156 and R157 form a balanced load



to reduce hum level in tubes V101, V104, and V105.

### 57. Audio Amplifier Circuit (fig. 48)

*a. General.* The input signal to the audio amplifier is taken from the output of the playback amplifier and fed to amplifier and phase inverter tube V302. The tube amplifies the signal and provides phase-inverted input signals for push-pull power-amplifier tubes V303 and V304. The output of the audio amplifier is connected to the internal loudspeaker or headset or external loudspeaker.

*b. Amplifier and Phase Inverter V302* (fig. 26). Input to the audio amplifier circuit are taken from MONITOR INPUT J303 and developed across MONITOR LEVEL control R317. A portion of the signal voltage is applied to the control grid of tube V302A. The amplified output developed across plate load resistor R307 is coupled out to tube V304 by capacitor C304. Amplified signal voltage is also developed across resistors R305 and R304. At the junction of resistors R305 and R304, signal voltage is coupled out by capacitor C302 to the control grid of tube V302B across resistor R302. The amplified signal of V302B is developed across plate load resistor R306 and coupled out to tube V303 by capacitor C303. Feed-back voltage to reduce distortion is taken from the secondary of transformer T302 and fed back to the cathode of tube V302A through filter resistor R310 and capacitor C305. Plate voltage for tube V302A and V302B is taken from the junction of resistor R315 and capacitor C307C.

*c. Power Amplifiers V303 and V304.* The input voltage to tubes V303 and V304 is taken from the output of tube V302A and V302B and is impressed across resistors R309 and R308. The amplified output of tubes V303 and V304 is developed across the primary of transformer T302. The output from the secondary is fed to either PHONES jack J302, EXTERNAL SPEAKER jack J301, or to internal loudspeaker LS301, through the contacts of selector switch S301. Plate voltage for the power-amplifier tubes is taken from the junction of resistors R314 and R315 and applied

through the primary of transformer T302. Screen voltages for the tubes are taken from the same junction and applied through taps on the primary winding of transformer T302. Common cathode bias is developed across resistor R312 and filtered by capacitor C306. Suppressor resistors R311 and R313, in the grid circuits, are used to prevent parasitic oscillation.

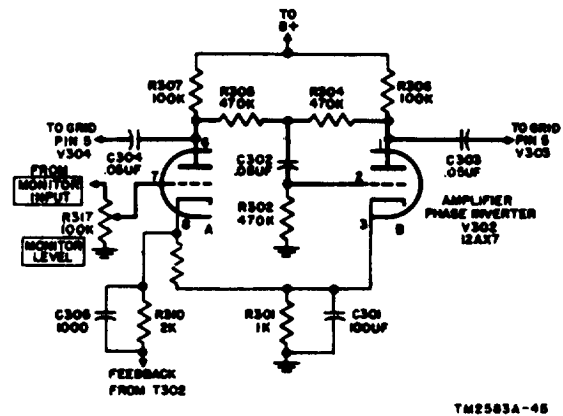

Figure 26. Amplifier phase-inverter circuit, simplified schematic diagram.

### 58. Audio Amplifier Power Supply (fig. 48)

*a.* The power supply circuit supplies dc plate and screen voltages for the phase inverter and power-amplifier tubes. The power supply also furnishes ac voltages for the filaments of the tubes in the audio amplifier and ac for pilot lamp I 301.

*b.* The 115-volt ac 60-cps line is connected to the primary of power transformer T301 through fuse F301. The stepped up voltages from the secondary of transformer T301 is connected to the plates of full-wave rectifier tube V301. The rectified output of tube V301 is filtered by capacitor C307A C307B, and C307C, and resistors R314 and R315.

*c.* Ac filament voltages for tubes V302, V308, and V304 are taken from the 6.3-volt secondary winding of power transformer T301. The same winding provides voltage for pilot lamp I 301 through surge resistor R316.

## CHAPTER 6

### FIELD MAINTENANCE

Note. This chapter contains information for field maintenance. The amount of repair that can be performed by units having field maintenance responsibility is limited only by the tools and test equipment available and by the skill of the repairman.

---

#### Section I. TROUBLE SHOOTING AT FIELD MAINTENANCE LEVEL

**Warning:** Certain points located throughout the chassis of the recorder-reproducer set are above 250 volts to ground. Do not touch these points while the power is on.

**Warning:** The failure of selenium rectifiers can result in the liberation of poisonous fumes and the deposit of poisonous selenium compounds. If a rectifier burns out or arcs over, the odor is strong. Provide adequate ventilation immediately. *Avoid inhaling the fumes and do not handle the damaged rectifier until it has cooled.*

#### 59. Trouble-shooting Procedures

*a. General.* The first step in servicing a defective recorder-reproducer set is to sectionalize the fault. Sectionalization means tracing the fault to the circuit responsible for abnormal operation. The second step is to localize the fault. Localization means tracing the fault to the defective part in the circuit. Some faults, such as burned-out resistors, arcing, and shorted transformers, can be located by sight, smell, or hearing. Some faults, however, must be localized by checking voltages and resistances.

*b. Sectionalization and Localization.* Listed below are tests and data that simplify the tracing of trouble. Follow the procedures in the sequence given. A serviceman must be careful

to cause no further damage to the equipment while it is being serviced. In general, the trouble is traced first to a circuit of the equipment and then to the faulty part in that circuit. The service procedure is summarized as follows :

- (1) *Visual inspection* (par. 39). Through visual inspection alone, the repairman may discover the trouble or locate the circuit in which the trouble exists. Visual inspection can prevent additional damage to the equipment through elimination of unnecessary or improper servicing methods.
- (2) *Trouble-Shooting chart.* The trouble symptoms listed in this chart (par. 65) will aid greatly in localizing trouble.
- (3) *Signal substitution.* If the proper signal generators are available, it may be preferable to use signal substitution in some cases (par. 67, 68, and 69).
- (4) *Intermittent.* The possibility of intermittent conditions should not be overlooked. This type of trouble may be made to appear by tapping or jarring the equipment gently. Test the wiring for loose connections and move the wires and parts with an insulated tool, such as a fiber rod.

## 60. Trouble-shooting Data

The service information in this manual will help in the rapid location of faults. Consult the following trouble-shooting data:

Fig. or par. No.	Title
Fig. 27	Amplifier chassis, top view.
Fig. 28	Amplifier chassis, bottom view, (capacitors not indicated).
Fig. 29	Amplifier chassis, bottom view, (resistors not indicated).
Fig. 30	Amplifier chassis, resistor-capacitor board (nearer to panel).
Fig. 31	Amplifier chassis, resistor-capacitor board (farther from panel).
Fig. 32	Audio amplifier chassis, top view.
Fig. 33	Audio amplifier chassis bottom view.
Fig. 34	Voltage and resistance chart, amplifier.
Fig. 35	Voltage and resistance chart, audio amplifier.
Fig. 36	Recorder-reproducer, top view.
Fig. 37	Recorder-reproducer, bottom view.
Fig. 38	Sound head assembly.
Fig. 39	Recorder-reproducer adjustment points.
Fig. 43	Block diagram of test set up.
Fig. 44	Playback amplifier, frequency response curve.
Fig. 45	Wording amplifier, frequency response curve.
Fig. 46	MIL-STD resistor color codes.
Fig. 47	MIL-STD capacitor color codes.
Par. 48	Recorder-reproducer.
Par. 49	Recording or playback circuit.
Par. 50	Fast rewinding circuit.
Par. 51	Fast winding circuit.
Par. 52	Recording input circuit.
Par. 53	Recording amplifier and erase-oscillator circuit.
Par. 61	Test equipment required for trouble-shooting.
Par. 63	Checking amplifier circuits for shorts.
Par. 64	Checking audio amplifier circuits for shorts.
Par. 65	Trouble-shooting chart.
Par. 66	Dc resistances of transformers and coils.
Par. 68	Signal substitution procedure audio amplifier.
Par. 69	Signal substitution procedure, amplifier.

## 61. Test Equipment Required

The test equipments required for trouble shooting the recorder-reproducer set are listed below with their common usage names. The

technical manual used with each equipment also is listed.

Signal Corps nomenclature	Common name	Technical manual
Audio Oscillator TS-382A/U	Audio oscillator	TM 11-2684A
Multimeter TS-352A/U	Multimeter	TM 11-5527
Electronic Multimeter TS-505/U	Vtvm	TM 11-5511
Sound Analyzer TS-615A/U	Distortion meter	TM 11-5032
Flutter Indicator PH-593/PFQ		
Spectrum Analyzer Test Set TS-723/U		
Electron Tube Test Set TV-2/U	Tube tester	TM 11-2661

## 62. General Trouble-shooting Precautions

Observe the following precautions whenever servicing the equipment:

a. Be careful servicing the equipment when it is out of the cases; dangerous voltages are present.

b. If the equipment has been operating for some time, use a cloth to remove the metal tube shields. Use a tube puller to remove hot tubes.

c. When servicing the erase-oscillator, do not disturb the wiring and placement of parts.

d. Do not overtighten screws on mechanical couplings.

e. When replacing a part that was held by screws, always replace the lock washers.

f. Careless replacement of parts often causes new faults. Note the following points:

- (1) Before a part is unsoldered, note the position of the leads. If a part, such as a transformer or switch, has a number of connections, tag each lead.
- (2) Be careful not to damage other leads by pushing or pulling them out of the way.
- (3) Do not use a large soldering iron for soldering small parts. Overheating a small part may damage or change the value of the part.
- (4) Do not allow drops of solder to drop on the chassis because a short circuit may result.
- (5) A carelessly soldered connection may create new faults.

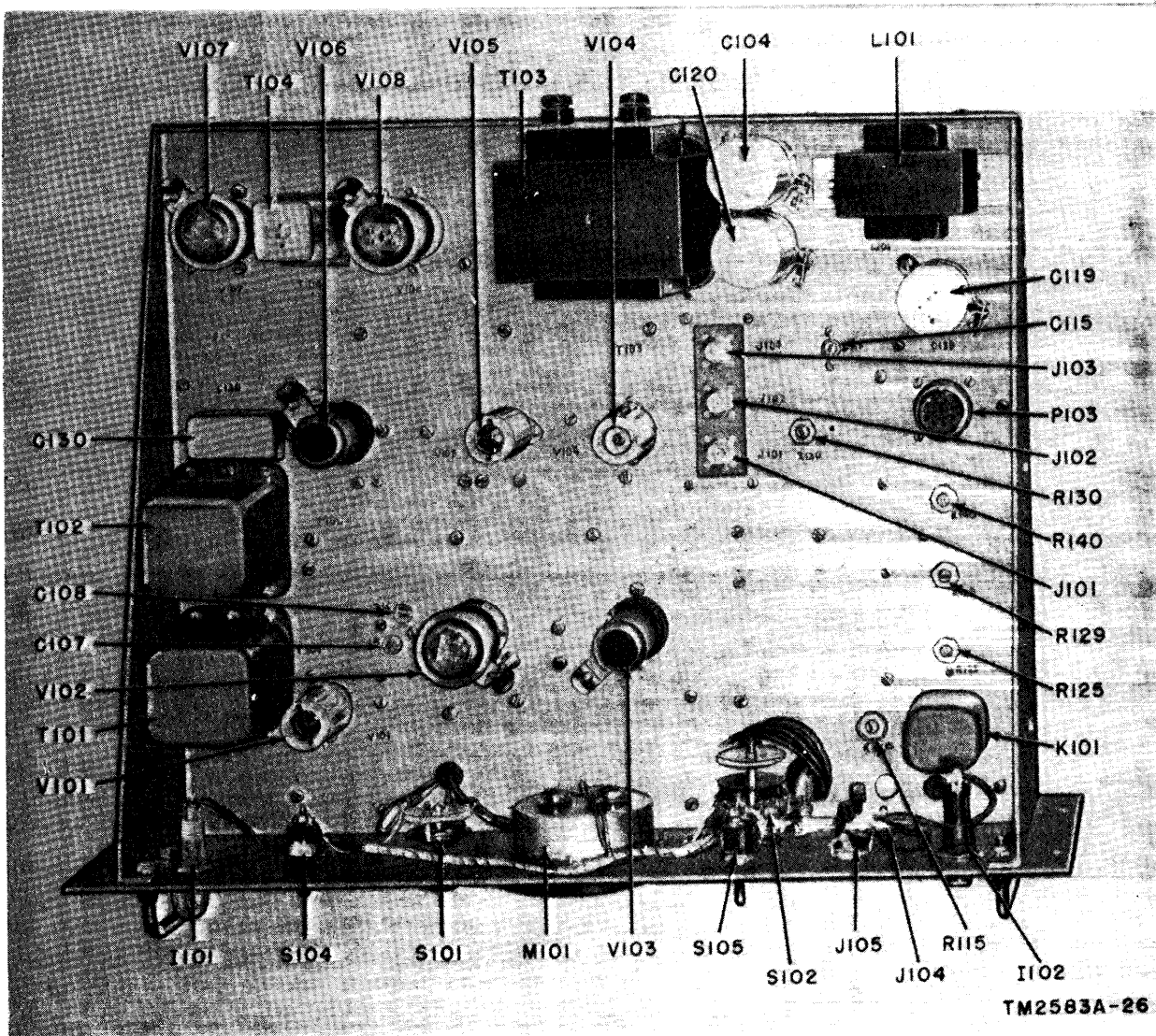

Figure 27. Amplifier chassis, top view.

- (6) Make well-soldered joints because a poorly soldered joint is one of the most difficult faults to find.
- (7) Replace a part exactly in the position occupied by the original part. Pay particular attention to proper grounding when replacing a part; use the same ground as in the original wiring. Failure to observe these precautions may result in decreased output or undesirable oscillation.

### 63. Chocking Amplifier Circuits for Shorts (fig. 27, 28, 29, 30, and 31)

Before servicing a unit suspected of defective operation, disconnect the power cables, the interconnecting cables, and the output cables. Also disconnect the microphone, the cable, and the headset.

*a.* Measure the resistance between pins B and G of connector P103. The reading should be 4 ohms. If the reading is incorrect, check fuses F101 and F102, connector P103, and the primary of transformer T103.

*b.* Measure the resistance across the 6.3-volt winding of transformer T103. The resistance should be more than .1 ohm. If the reading is incorrect, remove and check tubes V102, V103, V106, and V107. Check the reading again; if it is still incorrect, check transformer T103.

*c.* Measure the resistances from the plates of rectifier V108 to ground. The reading from pins 4 and 6 should be 250 ohms. If the reading is incorrect, check the high voltage secondary of transformer T103.

*d.* Measure the resistance across the 12.6-volt filament of T103. The reading should be more than .2 ohm. If the reading is incorrect, remove and check tubes V101, V104, and V105, and transformer T103. If the reading is still incorrect, check resistors R155, R156, and R157, capacitor C119, and selenium rectifier CR101. Also check the winding of transformer T103.

*e.* Measure the resistance from the cathode of V108 to ground. The reading should be 16K. If the reading is incorrect, check capacitors C120 and C104, resistors R161, R158, R137, and R135, and relay K101.

*f.* Measure the resistances from the plates of tubes V101, V102, V103, V104, V105, V106,

and V107. Check the readings against those in figure 34. If the readings are incorrect, refer to the trouble-shooting chart (par. 65).

*g.* Measure the resistances from the screen grids of tubes V101, V104, and V105. Check the readings against those in figure 34. If the readings are incorrect, refer to the trouble-shooting chart (par. 65).

*h.* Turn INPUT SELECTOR SWITCH S101 to the MIC position.

*i.* Measure the resistance across terminals 1 and 2 of OUTPUT connector P102. The reading should be 65 ohms. If the reading is incorrect, check EARPHONES jack J104 and the secondary of transformer T102. Check OUTPUT connector P102.

*j.* Measure the resistance between pins 2 and 3 of INPUT connector P101. The reading should be 25 ohms. If the reading is incorrect, check transformer T101, switch S101, and connector P101.

### 64. Checking Audio Amplifier Circuits for Shorts (fig. 32, 33, and 35)

Before checking the amplifier circuits, be sure that all cables have been disconnected. Also disconnect the external loudspeaker and headset.

*a.* Measure the resistance between the contacts of connector P301. The reading should be 4 ohms. If the reading is incorrect, check fuse F301 and the primary of transformer T301.

*b.* Measure the resistance across the filament winding of transformer T301. The reading should be less than 1 ohm. If the reading is incorrect, remove and check all tubes. Also check resistor R316 and POWER lamp I 301.

*c.* Measure the resistance from the cathodes of tube V301 to ground. The resistance should be 100K ohms minimum. If the resistance is incorrect, check capacitor C307 and resistors R314 and R315.

*d.* Measure the resistance from the plates of tubes V302, V303, and V304 to ground. Check the readings against those in figure 35. If the readings are incorrect, refer to the trouble-shooting chart (par. 65).

*e.* Measure the resistance from the screens of tubes V303 and V304. The readings should be 100K ohms. If the readings are incorrect, check the primary of transformer T302.

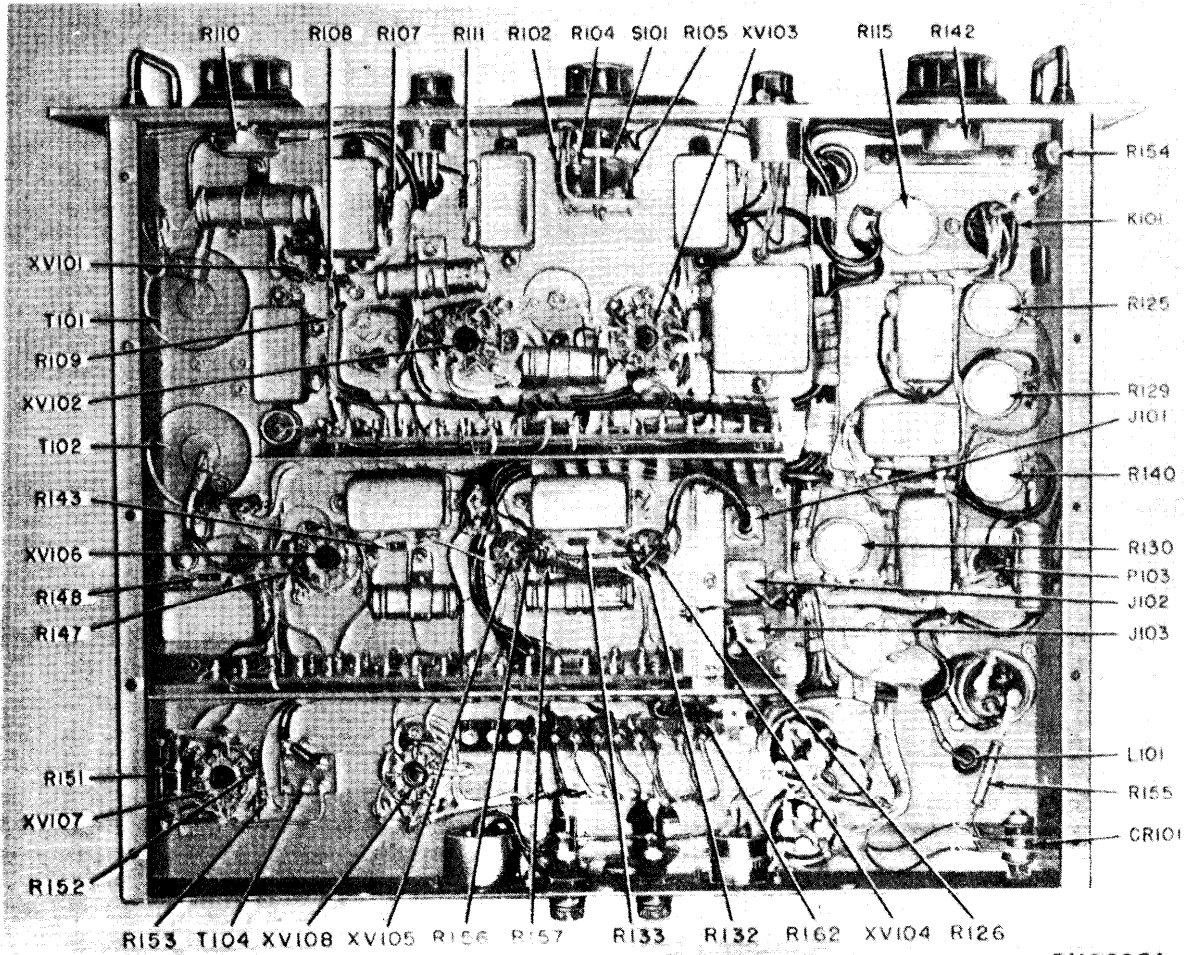

TM2583A-27

Figure 28. Amplifier chassis, bottom view (capacitors not indicated).

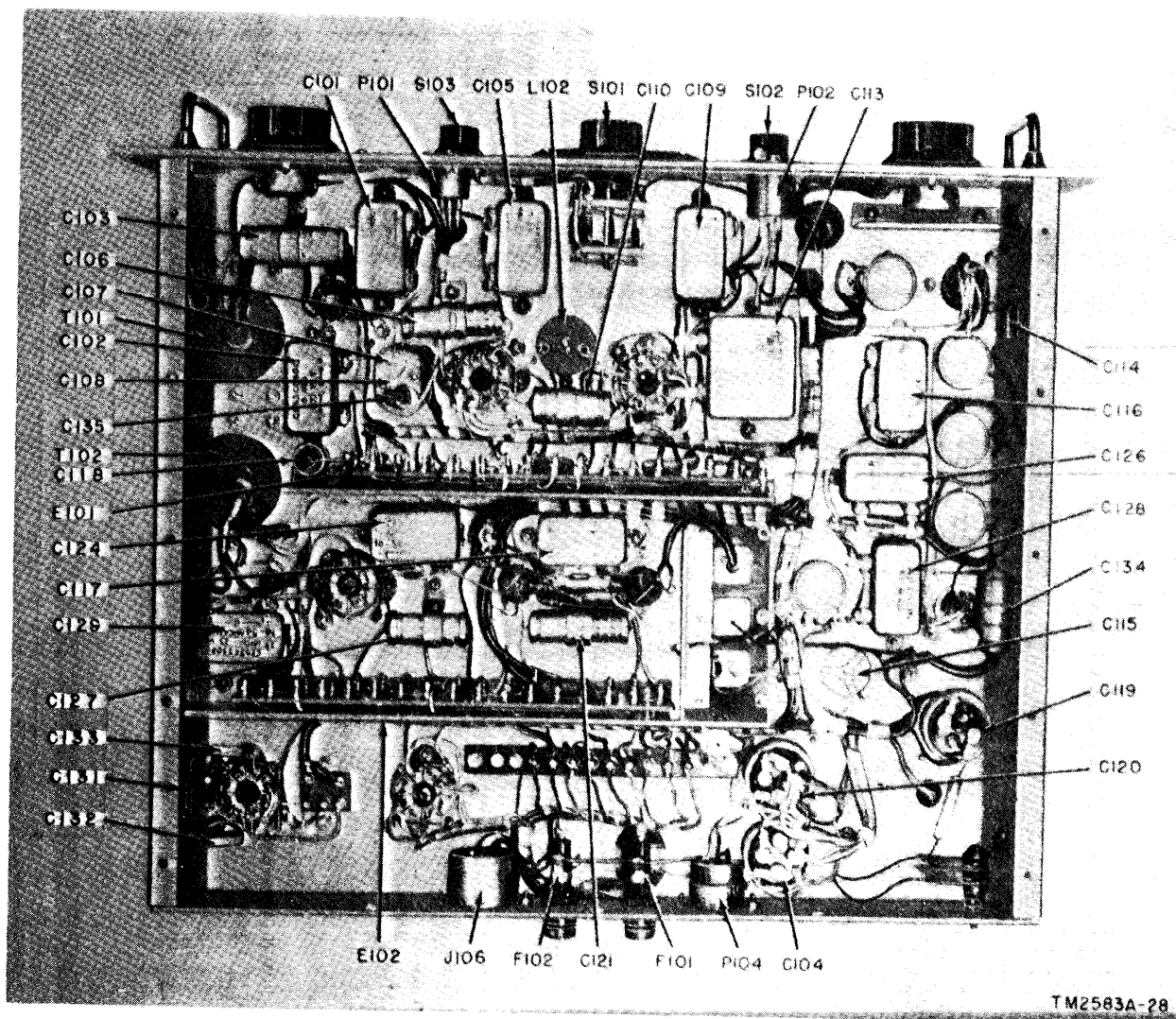
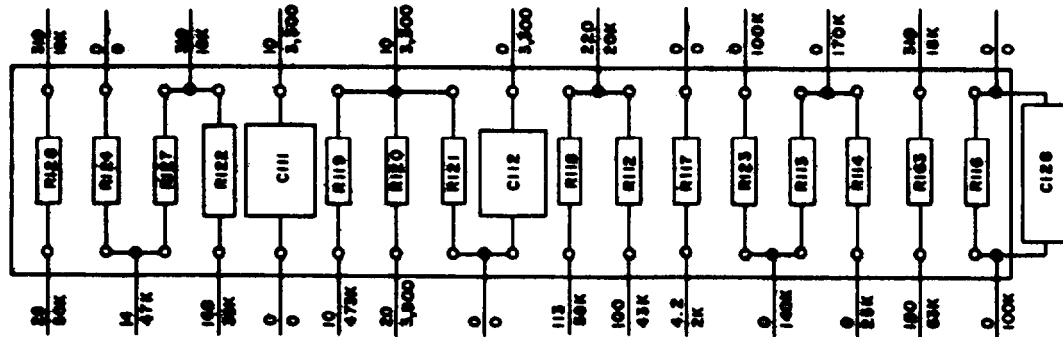

Figure 29. Amplifier chassis, bottom view (resistors not indicated).





- NOTES:
1. ALL VOLTAGES ARE ABOVE THE LINE AND ARE DC.
  2. ALL RESISTANCES ARE BELOW THE LINE.
  3. ALL VOLTAGES MEASURED WITH MULTIMETER TS-382/U (20000 OHMS/VOLT), OR EQUAL.
  4. ALL RESISTANCES MEASURED TO GROUND WITH **METER SELECTOR** IN **PLAYBACK LEVEL**, AND **RECORD LEVEL**, AND **PLAYBACK LEVEL**. CONTROLS OPERATED TO SETTING **10**

TMR563A-25

Figure 30. Amplifier chassis, resistor-capacitor board (nearer to panel).





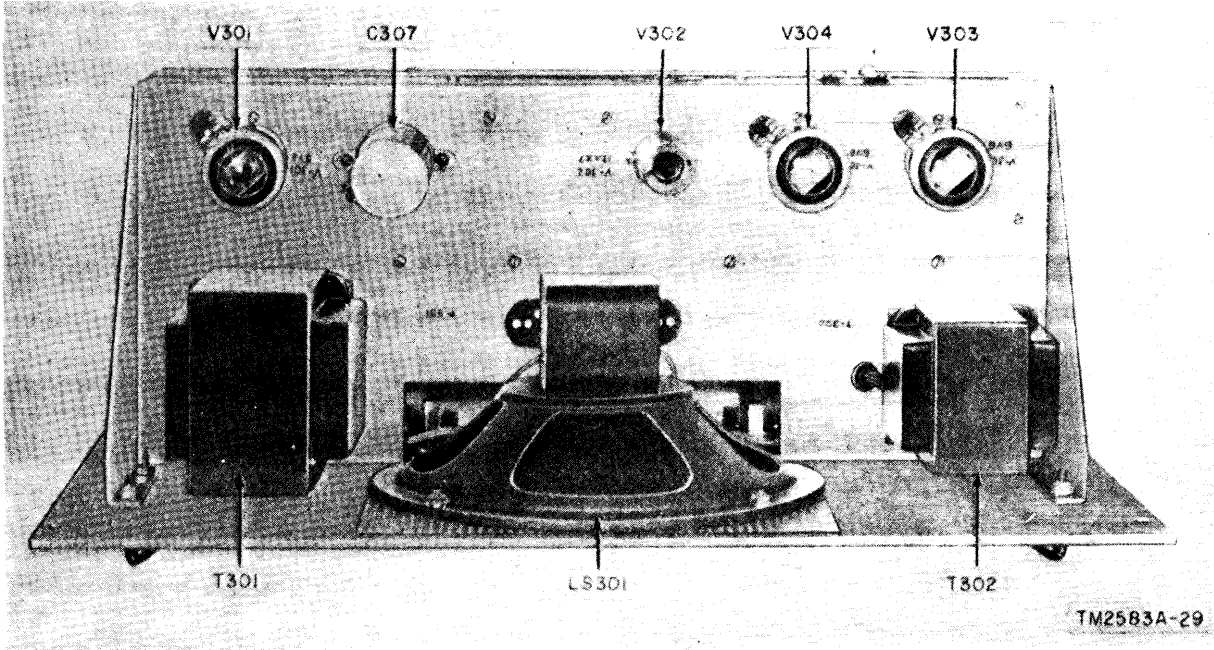

Figure 32. Audio amplifier chassis, top view.

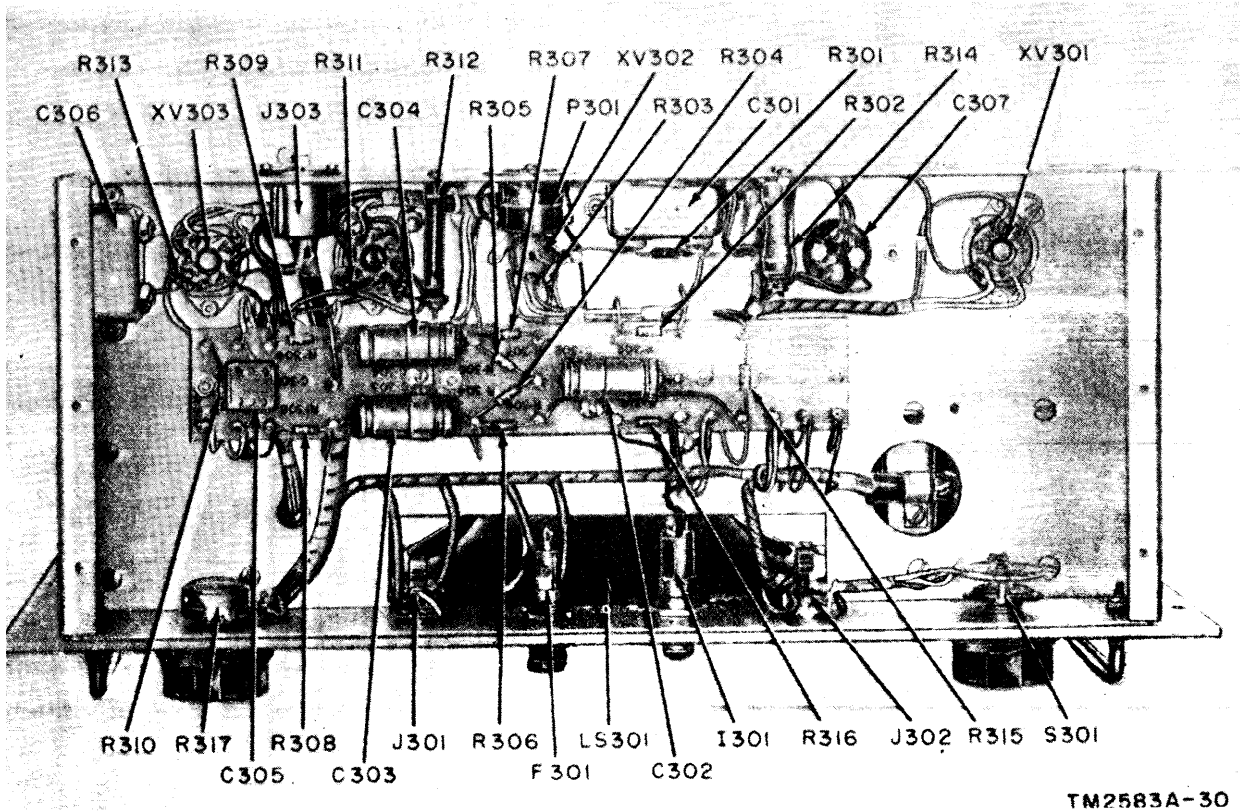

Figure 33. Audio amplifier chassis, bottom view.

## 65. Trouble-shooting Chart

The following chart lists the symptoms which the repairman may observe. After the

trouble has been localized, a tube check and voltage and resistance measurements should isolate the defective part.

Symptom	Probable cause	Remedy
1. Recorder-reproducer set inoperative.	1. No ac power. Defective Power Cable Assembly CX-1208/U. Defective connector P103. Defective connector P104. Defective connector P205. Defective fuse F101 or F102. Defective switch S203. Defective transformer T103.	1. Check power source. Repair or replace power cables  Replace connector P103. Replace connector P104. Replace connector P205. Replace fuse F101 or F102. Replace switch S203 (par. 70) Replace transformer T103 (par. 70).
2. Capstan does not rotate with switch S204 in either the 7 1/2" or the 15" position.	2. Defective switch S204. Defective capstan motor B202.  Defective capacitor C204.	2. Replace switch S204. Replace capstan motor B202 (par. 72).  Replace capacitor C204.
3. Capstan roller does not close with PLAY switch S206 pressed.	3. Defective switch S206. Defective rectifier CR201. Defective resistor R201. Defective capacitor C203. Defective switch S202. Defective relay K201.  Defective STOP switches S201.	3. Replace switch S206. Replace rectifier CR201. Replace resistor R201. Replace capacitor C203. Replace switch S202. Replace relay K201 (par. 70).  Replace STOP switch S201.
4. Tape spills.	4. Brake O 201 not released, solenoid L201 defective.  Resistor R203 shorted.	4. Replace O 201 or L201 (par. 71).  Replace resistor R203.
5. Tape breaks.	5. Defective solenoid L203.  Brake O 203 defective. Resistor R202 shorted.	5. Check, replace, or adjust L203 (par. 71) Replace O 203 (par. 71). Replace R202.
6. Tape is distorted or stretched.	6. Tape not threaded properly. Improper tension. Gate of sound head assembly not closed.	6. Refer to paragraph 13. Close the gate.
7. No output signal at EAR-PHONES jack J104 with audio amplifier disconnected.	7. Defective jack J104. Defective transformer T102.  Defective power supply.  Defective playback amplifier.	7. Replace jack J104. Replace transformer T102 (par. 70).  Check power supply (items 8, 9, and 10). Check amplifier (items 9 through, 16).

Symptom	Probable cause	Remedy
8. Same as item 7. No voltage at pins 2 and 8 of tube V108.	8. Defective fuse F102. Defective transformer T103.  Defective tube V108. Capacitor C120A shorted.  Defective filament rectifier and filter circuit.  Shorted filament.  Lamp I102 shorted	8. Replace fuse F102 (par. 41). Check all windings of transformer T103 (par. 66). Replace transformer T103 if defective (par. 70). Replace tube V108 (par. 40). Replace capacitor C120A. Check rectifier CR101. Check resistor SR155, R156, and R157. Check capacitor C119. Check all filaments. Replace defective parts. Check lamp I102. Check resistor R162.
9. Same as item 7.  Incorrect voltage at plate of tube V106 after previous checks have been made.	9. Tube V106 shorted.  Defective primary of transformer T102. Defective filament winding of transformer T102. Defective capacitor C120B or C120C. Defective resistor R161 or R154. Defective choke L101. Resistor R131 shorted. Defective resistor R148. Defective capacitor C129.	9. Check tube V106 (par. 40). Check transformer T102 (par. 66 and 70).  Replace defective parts.
10. Same as item 7. Incorrect voltage at plate of tube V106.	10. Capacitor C127 shorted.	10. Check capacitor C127 and resistor R147.
11. Same as item 7. Incorrect voltage at plate of tube V105.	11. Defective tube V105. Defective resistor R158, R146, R145, R143, or R144. Defective capacitor C104C, C124, or C125.	11. Check tube V105 (par. 40). Check defective parts.
12. Same as item 7. Incorrect voltage at screen grid of tube V 105 after previous checks have been made.	12. Defective resistor R145. Defective capacitor 126.	12. Check and replace defective parts.
13. Same as item 7. Incorrect voltage at control grid of tube V105.	13. Capacitor C121 shorted.	13. Check and replace capacitor C121.

Symptom	Probable cause	Remedy
14. Same as item 7. Incorrect voltage at plate of tube V104 after previous checks have been made.	14. Defective tube V104. Defective resistor R136 or R133. Defective capacitor C117 or C104B.	14. Check tube V104 (Par. 40). Replace defective parts.
15. Same as item 7. Incorrect voltage at screen grid of tube V104 after previous checks have been made.	15. Defective resistor R134 or R135. Defective capacitor C118.	15. Check and replace defective parts.
16. Same as item 7. Incorrect voltage at control grid of tube V104 after previous checks have been made.	16. Defective resistor R132. Defective jack J101. Defective interconnecting cable to connector J101. Defective connector P201. Defective connector J201 or J204. Defective reproducer head E201.	16. Check resistor R132. Check and replace defective parts.
17. Poor high frequency response.	17. Reproducer head misaligned. Defective resistor R139, R141 or R140. Defective capacitor C122 or C123.	17. Refer to paragraph 82. Check and replace defective parts.
18. Volume does not vary when the PLAYBACK LEVEL control is varied.	18. Defective PLAYBACK LEVEL control R142. Defective METER SELECTOR switch S102.	18. Check and replace defective parts (par. 70).
19. Needle of vu meter M101 does not vary with variation in sound level.	19. Defective vu meter M101. Defective resistor R138.	19. Check vu meter. Check resistor R138. Replace defective parts.
20. No output signal heard from loudspeaker LS301 with switch S301 turned to SPEAKER position.	20. Defective amplifier. Defective power supply. Defective switch S301. Defective loudspeaker LS301.	20. Check amplifier (items 21 through 80).
21. No output signal heard through external speaker.	21. Same as item 20. Defective jack J301.	21. Same as item 20. Check and replace jack J301
22. No output signal heard from headset connected to the PHONES jack with switch S301 at the PHONES position.	22. Same as item 20. Defective headset. Defective jack J302.	22. Check headset. Check jack J302. Replace defective parts.

Symptom	Probable cause	Remedy
23. Same as items 20 through 22 except that switch S301 is in the SPEAKER PHONES position.	23. Same as item 20.	23. Same as item 20.
24. Same as item 20.  No voltage at pins 2 and 8 of tube V301.	24. Defective tube V301.  Defective windings of transformer T301. Defective resistor R314. Defective lamp I301. Defective capacitor C307A. Defective fuse F301. Defective connector P301. Defective power cable assembly CX-1208/U.	24. Replace tube V301 (par. 40). Check and replace defective parts.  (For fuse replacement, refer to paragraph 41. For checking and replacement of transformer T301, refer to paragraphs 66 and 70).
25. Same as item 20. Incorrect voltages at plates and screen grids of tubes V303 and V304 after previous checks have been made.	25. Defective resistor R314, R315, or R312. Defective capacitor C307B, C307C, or C306. Defective tube V303 or V304. Defective transformer T302.	25. Check and replace defective parts (par. 70).
26. Same as item 20. Incorrect voltages at control grids of tubes V303 and V304 after previous checks have been made.	26. Capacitor C303 or C304 shorted. Defective resistor R308, R309, R311, or R313.	26. Check capacitors C303 and C404. Check resistors R308, R309, R311, and R313.
27. Same as item 20.  Incorrect voltages at plates of tube V302 after previous checks have been made.	27. Defective tube V302.  Defective resistor R306, R307, R330, R301 or R310. Defective capacitor C301 or C305.	27. Replace defective tube V302 (par. 40).  Check and replat defective parts.
28. Incorrect voltage at pin 2 of tube V302 after previous checks have been made.	28. Defective resistor R304 or R305. Defective capacitor C302.	28. Check resistors R304 and R305.  Check capacitor C302. Replace defective parts.
29. Incorrect voltage at pin 7 of tube V302 after previous checks have been made.	29. Defective R317. Defective J303. Defective interconnecting cable.	29. Check and replace defective parts.
30. Level of sound does not vary when variable resistor R317 is varied.	30. Defective variable resistor R317.	30. Check and replace variable resistor R317.
31. Equipment does not atop when STOP switch S201 is pressed.	31. Defective switch S201.	31. Check and replace switch S201
32. Equipment does not rewind quickly with REWIND switch pressed.	32. Defective REWIND switch S207. Defective relay K202. Defective relay K201.	32. Check switch S207.  Check relay K202. Check relay K201. Replace defective parts (par. 70).

Symptom	Probable cause	Remedy
33. Equipment does not wind quickly with WIND switch pressed.	33. Defective WINDswitch S203. Defective relay K203.	33. Check switch S205. Check relay K203. Replace defective parts (par. 70).
34. RECORD INDICATOR does not glow with RECORD switch closed.	34. Defective interconnecting cable. Defective connector P103. Capacitor C134 shorted. Defective relay K101. Defective RECORD INDICATOR I 102.	34. Check and replace defective parts.  Refer to paragraph 70.
35. With a microphone input signal and METER SELECTOR switch S102 operated to PLAYBACK LEVEL position, recorded signal is not heard.	35. Defective recording amplifier. Defective recorder head E202. Defective connector P202. Defective connector J102.	35. Check recording amplifier (items 36 through 43.)
36. Same as item 35.  Incorrect voltage at plate of tube V103.	36. Defective tube V103.  Defective resistor R128, R129, R127, R124, R122, R120, or R121. Capacitor C112 or C113 shorted.	36. Check and replace tube V103 (par. 40). Check and replace defective parts.
37. Same as item 35. Incorrect voltage at control grid of tube V103.	37. Capacitor C110 shorted.	37. Check capacitor C110. Check resistor R119. Replace defective parts (par. 70).
38. Same as item 35.  Incorrect voltage at plate of tube V102B.	38. Defective tube V102B.  Defective resistor R118 or R117. Defective capacitor C109.	38. Check and replace tube V102B (par. 40). Check and replace defective parts.
39. Same as item 35. Incorrect voltage at control grid of tube V102B.	39. Defective capacitor C106. Defective resistor R113, R123, or R126.	39. Check capacitor C106. Check resistors R113, R123, and R126.
40. Same as item 35.  Incorrect voltage at plate of tube V102A.	40. Defective tube V102A.  Defective resistor R112 or R111. Capacitor C106 shorted.	40. Check and replace defective parts. Check and replace tube V102. (par. 40). Check and replace defective parts.
41. Same as item 35. Incorrect voltage at control grid of tube V102A.	41. Capacitor C103 shorted. Resistor R110 defective.	41. Check capacitor C103. Check resistor R110. Replace defective parts.
42. Same as item 35.  Incorrect voltages at plate and screen grid of tube V101.	42. Defective tube V101  Defective resistor R163, R108, R109, or R107. Defective capacitor C104A, C102, or C101.	42. Check and replace tube V101. (par. 40). Check and replace defective parts.

Symptom	Probable cause	Remedy
43. Same as item 35.	43. Defective transformer T101 (par. 66). Defective INPUT SELECTOR SWITCH S101. Defective INPUT connector. P101. Defective microphone or microphone cable.	43. Replace defective parts (par. 70).
44. Equipment does not record signal to bridging circuit input.	44. Defective resistor R159, R160, R101, R102, R103, or R104.  Defective switch S101.	44. Check switch S101. Replace if defective; refer to paragraph 70. Replace defective resistors.
45. Equipment does not record signal to 600-ohm balanced line input.	45. Defective resistor R105, or R106.  Defective switch S101.	45. Check switch S101. Replace if defective; refer to paragraph 70. Replace defective parts.
46. Equipment does not record signal to 600-ohm unbalanced line input.	46. Defective switch S101.	46. Check and replace switch S101 (par. 70).
47. Level of sound does not vary when RECORD LEVEL control is turned.	47. Defective control R110.	47. Check and replace control R110.
48. Poor frequency response.	48. Defective resistors R113, R114, R115, R116, or R123. Defective EQUALIZATION switch S 103. Defective capacitor C107, C108, C121, C111, or C112. Defective coil L102.	48. Check and replace defective parts.
49. Distortion present during monitoring of recording on a previously recorded tape.	49. Erase-oscillator V107 defective. Defective erase head E203. Defective connector P203. Defective interconnecting cable. Defective connector J103.	49. Replace tube V107 (par. 40) (see items 50 through 52). Replace defective parts.
50. Same as item 49. Incorrect voltages at plates of tube V107.	50. Defective transformer T104. Defective capacitor C131.	50. Check and replace defective parts (par. 70).
51. Same as item 49. Incorrect voltages at control grids of tube V107.	51. Defective resistor R151, R152, R153, or R162. Defective capacitor C132, or C133.	51. Replace defective parts.
62. Same as item 49.	52. Capacitor C115 defective. Defective connector J103. Defective resistor R126.	52. Replace defective parts.
53. Excessive recording noise.	53. Noise balance circuit misaligned.	53. Refer to paragraph 85.



## 66. Dc Resistances of Transformers and Coils

The dc resistances of the transformers and coils in the recorder-reproducer set are listed below.

Transformer or coil	Leads	Ohms
K101	1 and 10	4,500
L101	Across coil	250
L102	Across coil	90
T101	Yellow to yellow Green to black	25 3,100
T102	Red to blue Brown to brown	1,600 65
T103	Black to black Green to green-yellow Green-yellow to green Red to red-yellow Red-yellow to red Yellow to yellow Brown to violet Violet to brown	4 Less than 1 Less than 1 250 250 Less than 1 Leas than 1 Less than 1
T104	Blue to red Red to blue Yellow to black	10 10 17
K201	1 and 10	4,500
K202	1 and 10	4,500
K203	1 and 10	4,500
L201	Across terminals	2,400
L202	Across terminals	1,200
L203	Across terminals	2,400
T301	Black to black Yellow to yellow Red to red-yellow Red-yellow to red Green to green-yellow Green-yellow to green	4 Less than 1 130 130 Less than 1 Less than 1
T302	Blue to blue-white Blue-white to red Red to green-white Green-white to green Yellow to black	85 35 35 85 Leas than 1

## 67. Signal Substitution

General notes on signal substitution and signal tracing are as follows:

a. An audio signal generator is required to generate the signal of proper voltage and frequency that is to be traced through the equipment.

b. An oscilloscope is used to observe the wave form, a vacuum-tube voltmeter to measure the voltage, or, under certain conditions, a loudspeaker or headset may be used to listen to the signal.

**Caution:** Do not remove the shield cans or other shields for tubes and parts unless the trouble has been traced to that particular part. Do not push the wiring out of place. Pushing the wiring back and forth may cause broken connections, change the frequency of the erase-oscillator, or alter the characteristics of a circuit.

c. When connecting a signal generator to the control grid of a tube, connect a capacitor (.05 microfarad) in series with the output (high side) of the signal generator.

d. After trouble is traced to a circuit, disconnect the test equipment and make voltage and resistance measurements to localize the defective part (fig. 30, 31, 34, and 35).

## 68. Signal Substitution Procedure, Audio Amplifier (fig. 48)

a. Set the signal generator (Audio Oscillator TS-382A/U or equivalent) to 1,000 cps.

b. Connect and operate the audio amplifier.

c. Turn the function switch to the SPEAKER position.

d. Connect the output of the signal generator through a suitable capacitor to the plate of tube V304. A signal should be heard from the loudspeaker (Do not overload the audio amplifier.) Connect the output of the signal generator to the control grid of tube V304. Signal volume should increase. If not, refer to the trouble-shooting chart (par. 65).

e. Repeat the procedure given in *d* above for tube V303 and for phase inverter V302. Reduce the level of the input signal for each successive stage.

## 69. Signal Substitution Procedure, Amplifier (fig. 49)

a. Set the signal generator (Audio Oscillator TS-382A/U or equivalent) to 1,000 cps.

b. Connect and operate the amplifier.

c. Turn METER SELECTOR switch S102 to the PLAYBACK LEVEL position.

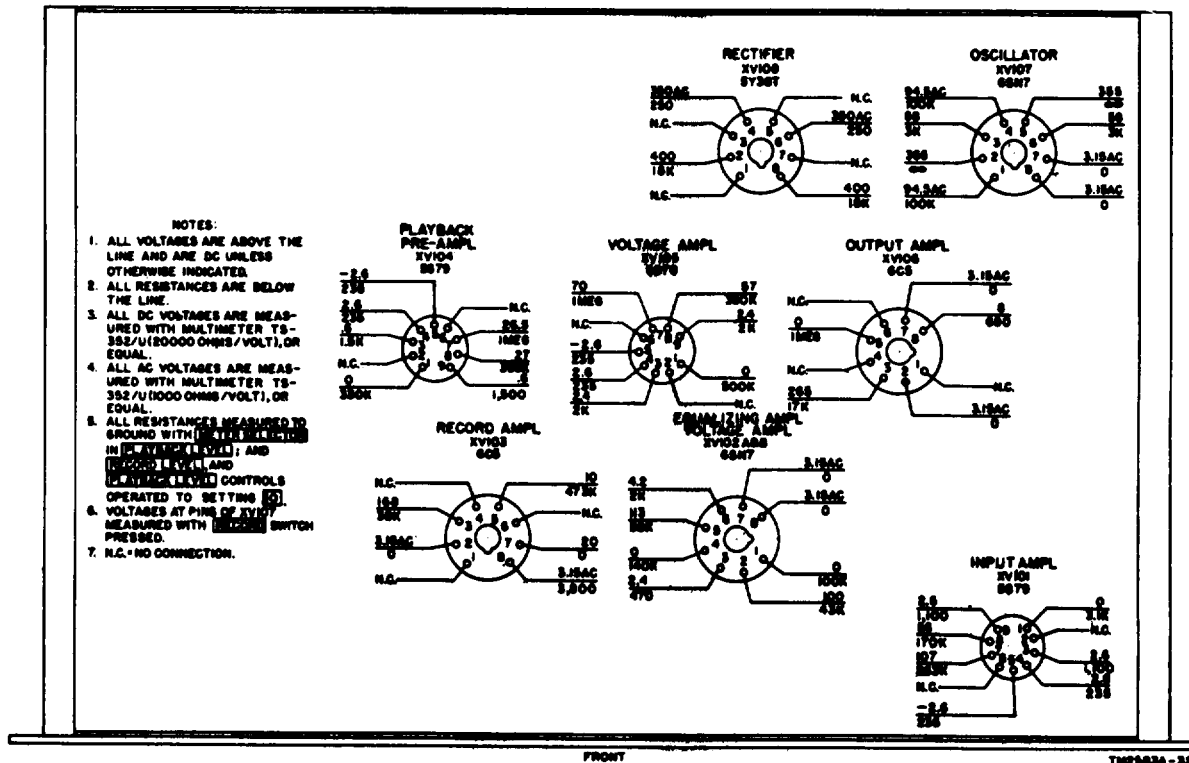

Figure 35. Voltage and resistance chart, audio amplifier.

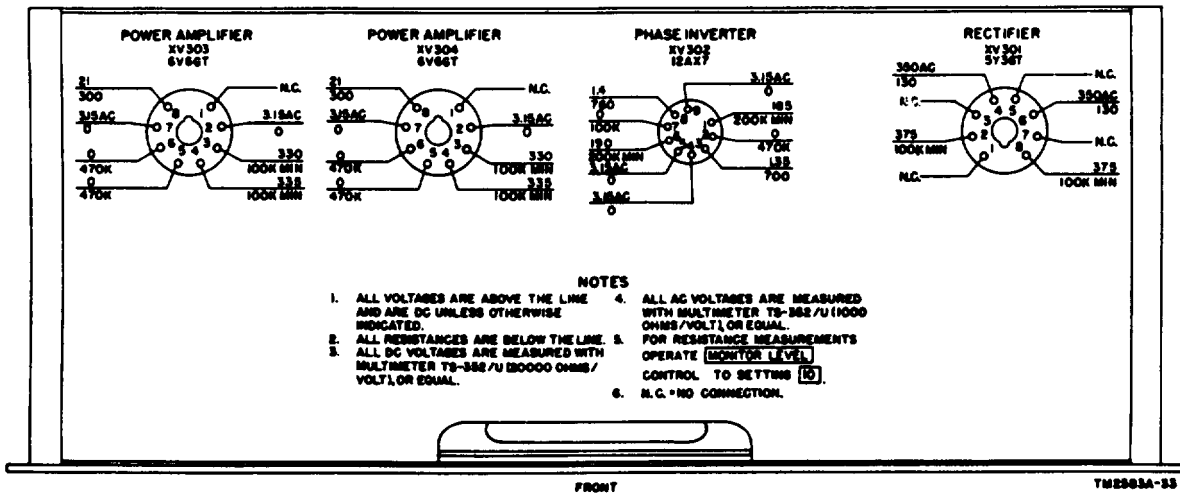

Figure 35. Voltage and resistance chart, audio amplifier.

*d.* Connect the headset to EARPHONES jack J104.

*e.* Connect the output of the signal generator through a suitable capacitor to the plate of tube V106. A signal should be heard in the headset. (Do not overload the amplifier.) Connect the output of the signal generator to the control grid of tube V106. Signal volume should increase. If not, refer to the trouble-shooting chart (par. 65).

*f.* Repeat the procedure given in *e* above

for tubes V105 and V104. Reduce the level of the input signal for each successive stage.

*g.* Turn the METER SELECTOR switch to the RECORD LEVEL position.

*h.* Repeat the procedure given in *e* above for tubes V102A and V101.

*i.* Remove the headset from EARPHONES jack J104 and connect it to contact 6 of relay K101 and ground;

*j.* Repeat the procedure given in *e* above for tubes V103 and V102B.

## Section II. REPAIRS

### 70. Replacement of Parts

*a.* Most of the components of the recorder-reproducer set are readily accessible and can be replaced easily using common hand tools.

*b.* If switch S101, S102, or S301 requires replacement, carefully mark the wires connected to the switch wafers with tags to avoid wiring errors.

*c.* If relay K101, K201, K202, or K203 (fig. 27 and 37) requires replacement, carefully mark the wires connected to the relays with tags to avoid wiring errors.

*d.* If transformer T101, T102, T108, T104, T301, or T302 requires replacement, carefully mark the wires with tags to avoid wiring errors.

### 71. Disassembly Procedure, Recorder-reproducer (fig. 36, 37, and 41)

Remove the recorder-reproducer from the case as follows:

*a.* Remove the editing knobs from both reels by rotating the knobs counterclockwise.

*b.* Be sure the tape is wound on one reel. Remove the tape reels.

*c.* Remove the hub adapters.

*d.* Remove the eight No. 10 screws that hold the recorder-reproducer to the case.

*e.* Lift the unit out of the case.

*f.* Disconnect the interconnecting power cable.

*g.* Disconnect connector P201 from connector J101, disconnect connector P202 from connector J102, and disconnect connector P203 from connector J203.

### 72. Replacement of Supply and Take-up Motors

To remove either of these motors, disconnect all leads, remove the recorder-reproducer (par. 71), and proceed as follows:

*a.* Remove the three No. 4 flat head screws that hold the spindle. Remove the spindle.

*b.* Remove and tag the electrical connections from the motor to terminal board E204 or E206 (fig. 37).

*c.* Remove the four No. 10 binding head screws that hold the motor to the front panel of the recorder-reproducer. Be sure to hold the motor and, at the same time, loosen the screws to prevent dropping the motor. Remove the motor.

*d.* Loosen the four No. 6 binding head screws that hold the brake assembly to the motor. Remove the brake assembly.

*e.* Loosen the two No. 8 Allen head screws that hold the brake pulley to the motor shaft.

*f.* To install the new motor, reverse the procedure outlined in *a* through *e* above.

### 73. Replacement of Capstan Motor

To remove the capstan motor (fig. 37), disconnect all leads, remove the recorder-reproducer (par. 71), and proceed as follows:

*a.* Remove and tag the electrical connections from the motor to terminal board E205.

*b.* Loosen the four No. 10 nuts that hold the motor to the recorder-reproducer assembly. Be sure to support the motor when loosening the nuts. Remove the motor.

*c.* To install the new motor, reverse the procedure outlined in *a* and *b* above.

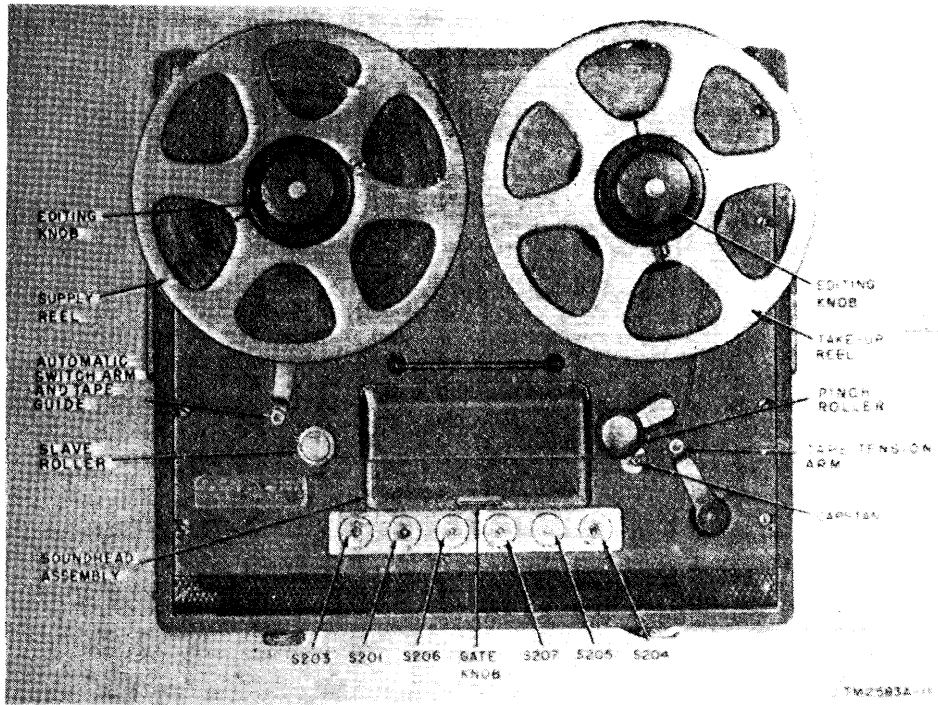

Figure 36. Recorder-reproducer, top view.

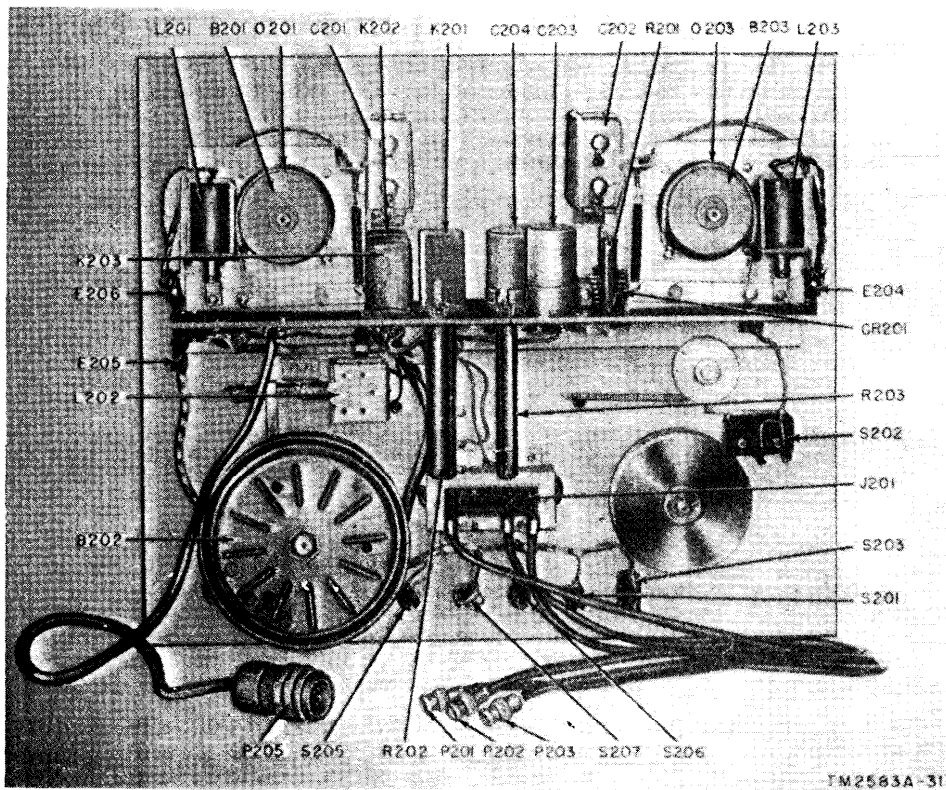

Figure 37. Recorder-reproducer, bottom view.

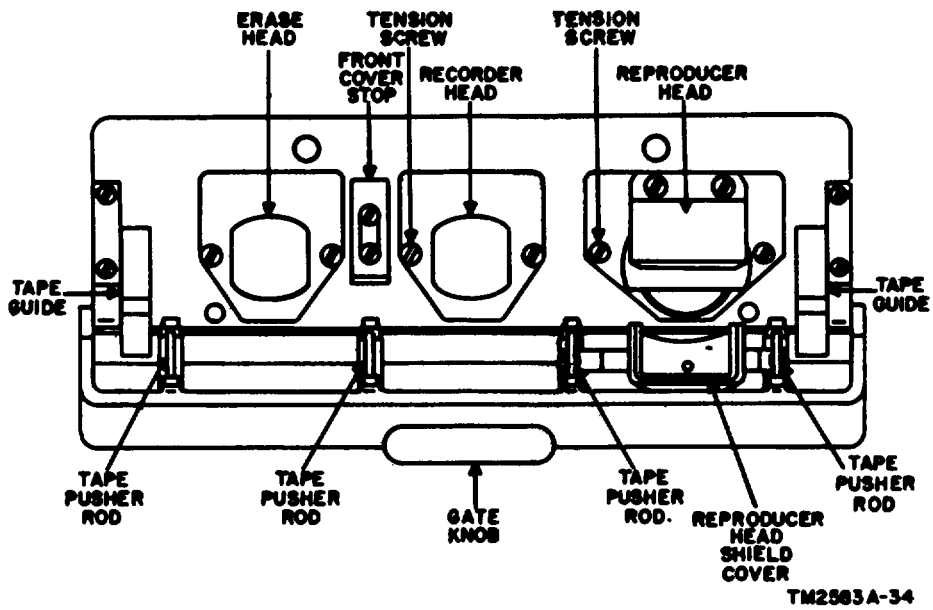

Figure 38. Sound head assembly.

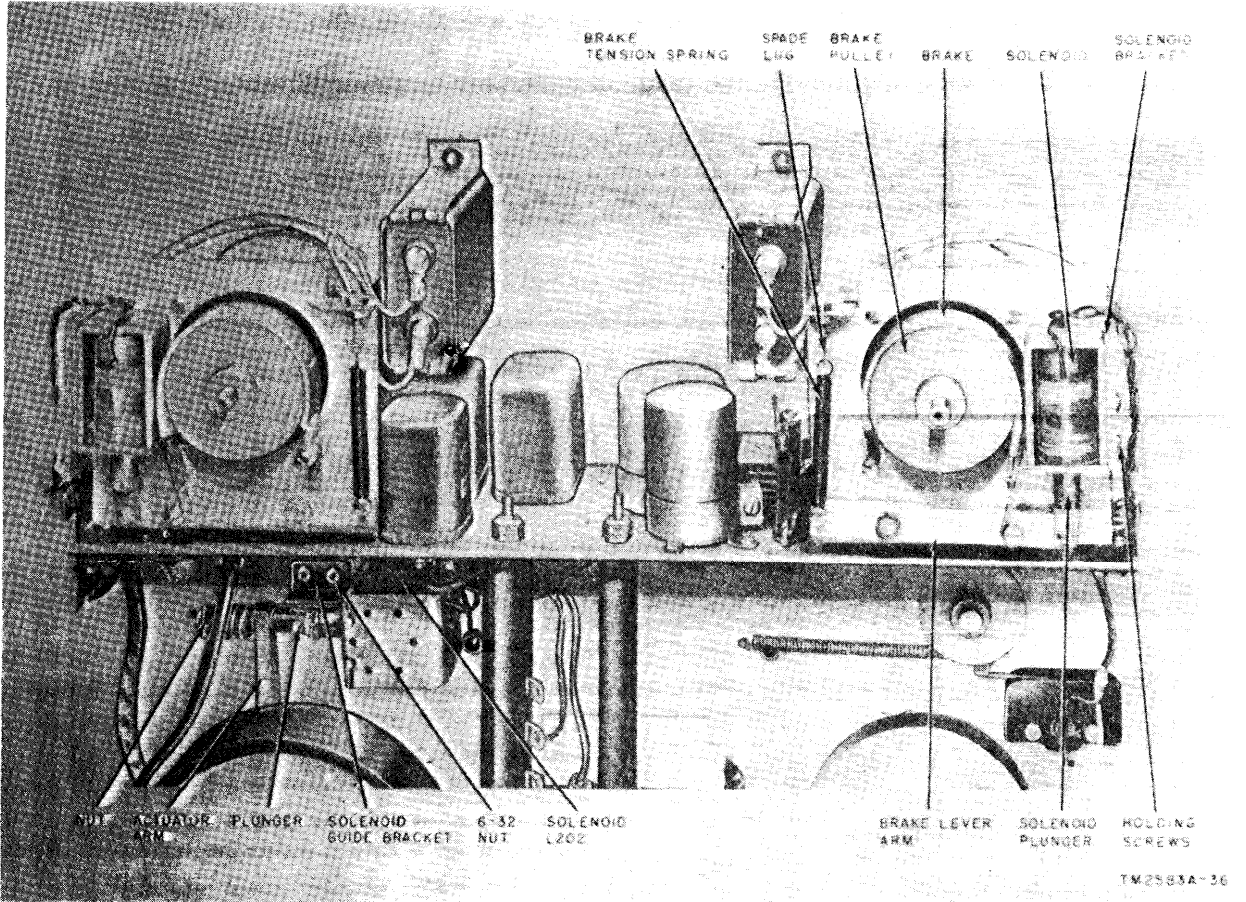

Figure 39. Recorder-reproducer, adjustment points.

#### 74. Replacement of Sound Head Assembly (fig. 38)

- a. Remove the two No. 6 binding head screws that hold the cover of the sound head assembly. Remove the cover.
- b. Remove the two No. 6 fillister head

screws and the two No. 6 binding head screws that hold the sound head assembly.

c. Lift off the sound head assembly.

d. To install the sound head assembly, reverse the procedure outlined in a through c above.

### Section III. MECHANICAL ADJUSTMENTS

#### 75. General

If a motor is replaced, the solenoid and the brake belt tensions of both the supply reel motor and the take-up reel motor must be adjusted. Follow the directions given in paragraphs 76 through 78 to make the adjustments.

#### 76. Solenoid Throw Adjustment (fig. 39)

To adjust the throw of the solenoid, proceed as follows:

- a. Push the plunger into the solenoid to the limit of travel.
- b. Release the solenoid plunger. The plunger should throw between 1/8 inch and 3/16 inch when released.
- c. If the throw is incorrect, adjust the solenoid by moving the two screws in the slots to obtain correct throw. Tighten the screws.

#### 77. Brake Belt Tension Adjustments (fig. 39)

a. *General.* The brake belts of the take-up reel and supply-reel motors require adjustment if the recording tape continually breaks or spills, or if the adjustments of the brakes are unequal. Proper braking action is such that the brakes will stop the motor in about 4 seconds with a full 10½-inch reel of tape on the turntable, or if a 1-pound pull is required to move the solenoid plunger.

b. *Adjustments.* To adjust the brake belt tension, proceed as follows:

- (1) Clean the surface of the brake pulley with Cleaning Compound (par. 31).
- (2) Adjust the two No. 8-32 nuts on the spade bolt that hold the brake tension spring until proper braking action is obtained (a above).

c. *Additional Adjustments.* When operating the equipment with a 7-inch reel, move the tape of resistor R202 (fig. 37) to the 150-ohm position.

#### 78. Pressure Roller Adjustment

To adjust the pressure roller against the tape capstan drive, proceed as follows:

a. Press the pinch roller against tape capstan shaft.

b. Loosen the two No. 6-32 nuts on the solenoid guide bracket (fig. 39).

c. Loosen, but do not remove, the two set screws on the lower end of the actuator arm (fig. 39).

d. Adjust the actuator arm until the solenoid plunger is approximately 1/16-inch away from the completely closed position.

*Note.* The pinch roller must be held in a closed position.

e. Tighten the set screws in the actuator arm.

f. Adjust the solenoid guide bracket to permit the pinch roller to open 1/8-inch from the capstan shaft.

g. Tighten the No. 6-32 nuts.

h. Adjust the large nut at the end of the solenoid plunger until the tape exerts a 1-pound pull when the solenoid is energized.

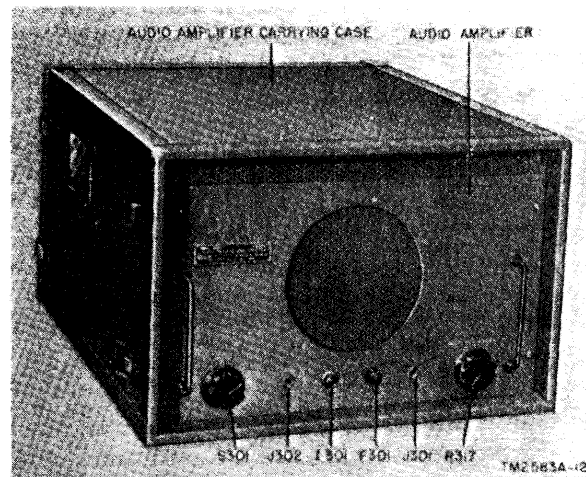

Figure 40. Audio amplifier, front view.



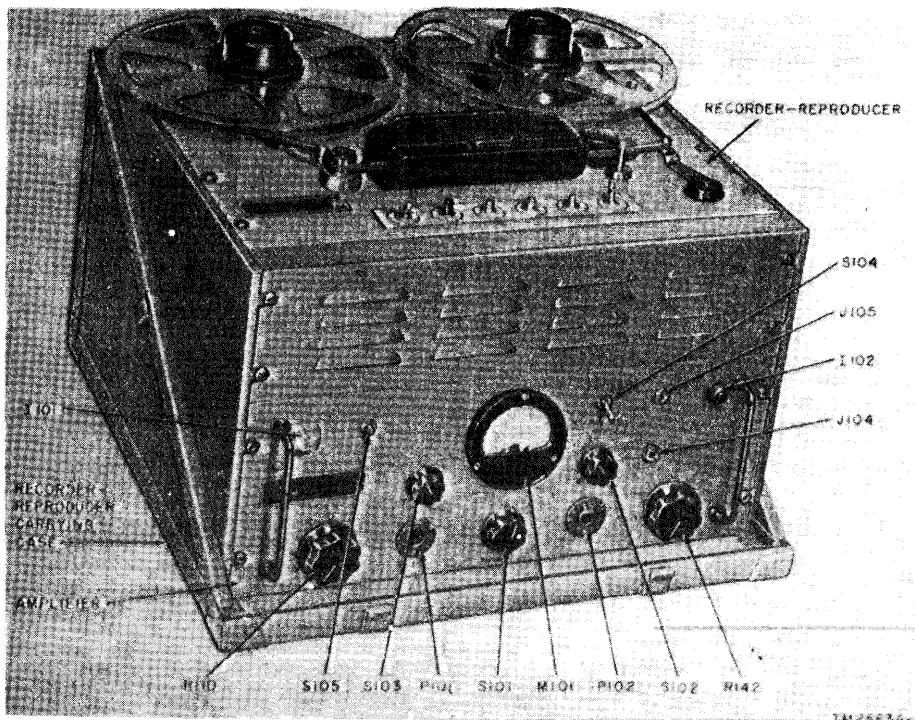

Figure 41. Amplifier carrying case, front view.

## Section IV. FINAL TESTING

### 79. Inspection After Repair

Before testing the equipment, a mechanical and electrical inspection should be performed.

#### a. Mechanical Inspection.

(1) Check all soldered connections.

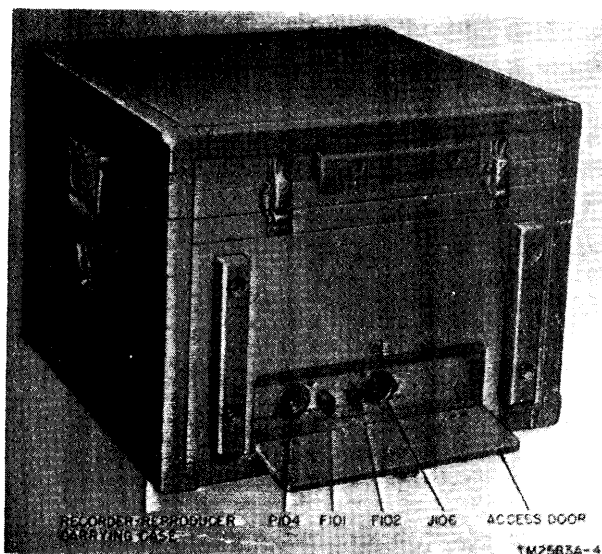
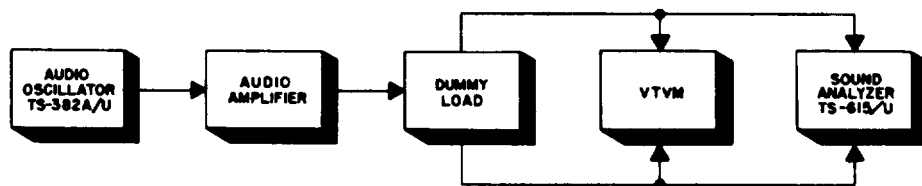

Figure 42. Recorder-reproducer carrying case, rear view, access door open.

- (2) See that all tubes are seated firmly in their respective sockets.
- (3) See that all resistor and capacitor leads are clear of adjacent terminals or lugs.
- (4) Look for drops of solder between terminals on rotary switches and elsewhere on the chassis.
- (5) Check for frayed wires and for sharp points of solder penetrating wire insulation.
- (6) See that all mounting screws are tight.
- (7) See that all cable clamps fit snugly over the cables.
- (8) Examine the core of loudspeaker LS301. Check the voice-coil connections.
- (9) See that the set screws on all panel control knobs make firm contact with their respective control shafts.
- (10) Check the action of all controls for positive response to knob rotation.
- (11) See that the pilot lamps and the RECORD INDICATOR lamp are secure in their sockets.



TM2583A-37

Figure 43. Block diagram of test setup.

b. *Electrical Inspection.* Refer to the equipment performance check list (par. 43), Check the equipment operation as a recorder, as a reproducer, and as a public address set.

**80. Audio Amplifier Check**  
(fig. 43)

To check the operation of the audio amplifier, proceed as follows:

- a. Turn function switch S301 to the SPEAKER position.
- b. Connect a dummy load of 8 ohms resistance rated at 20 watts to the EXTERNAL SPEAKER jack with a suitable connector,
- c. Connect the audio amplifier to a 115-volt, 60-CPS line and allow at least 5 minutes for warm up.
- d. Connect a vtm across the dummy load.
- e. Connect a distortion meter across the dummy load.
- f. Connect an audio oscillator across contacts 1 and 3 of the MONITOR INPUT connector.
- g. Adjust the output of the audio oscillator to 3 volts at 400 cps.
- h. Adjust the MONITOR LEVEL control until the vtm indicates 8 volts ac.
- i. The distortion meter should indicate less than 1 per cent distortion.
- j. Repeat the instructions given in h and i above for frequencies of 400, 1,000, 5,000, and 10,000 cps.

**81. Audio Amplifier Gain**

To check the over-all gain of the audio amplifier, proceed as follows:

- a. Connect the equipment as indicated in paragraph 80.
- b. Connect a dummy load as indicated in paragraph 80.
- c. Turn the MONITOR LEVEL control to a setting of 10.
- d. Adjust the output of the audio oscillator to 1.5 Volta.
- e. The needle of the vtm should indicate 8 volts ac.

**82. Frequency Response, Playback Amplifier Circuit of Amplifier**  
(fig. 44)

- a. Connect a voltage divider (3.3K and 10 ohms) across the output of an audio oscillator. Connect the playback input jack J101 of the

amplifier to the 10-ohm resistor of the voltage divider.

- b. Turn the METER SELECTOR switch to the PLAYBACK LEVEL position.
- c. Move the LINE TERMINATION switch to the ON position.
- d. Connect a vtm across pins 2 and 3 of the OUTPUT connector.
- e. Connect the equipment to a 115-v, ac 60-cps power source and allow at least 5 minutes for warm up.
- f. Adjust the output of the audio oscillator to 1 volt at 50 cps for all measurements.
- g. Adjust the PLAYBACK LEVEL control until the needle of the vtm indicates 4 volts.
- h. Adjust variable resistor R140 (fig. 27) to obtain the frequency response curve indicated in figure 44. Readings may vary  $\pm 2$  db. Use the chart below.

Frequency	Output (volts)
50 cps	4
1 kc	.3
5 kc	.11
10 kc	.12

**83. Amplifier Gain, Playback Amplifier Circuit of Amplifier**

To check the over-all gain of the playback amplifier, proceed as follows:

- a. Connect the equipment as indicated in paragraph 82.
- b. Operate the LINE TERMINATION switch to the OFF position.
- c. Operate the equipment for playback.
- d. Connect an audio oscillator to the voltage divider (fig. 44). Adjust the audio oscillator for a 1-volt output at 1 kc.
- e. Operate the PLAYBACK LEVEL control to a setting of 10.
- f. Operate the METER SELECTOR switch to the PLAYBACK LEVEL position. Vu meter M101 should indicate -6 vu  $\pm 2$  vu.

**84. Frequency Response, Recording Amplifier Circuit of Amplifier**  
(fig. 45)

The frequency response of the recording amplifier should be checked for both 15-ips and 7 1/2-ips operation. Check the 15-ips operation as follows:

- a. Connect a 1K resistor from the junction of capacitor C113 (fig. 27) and resistor R127

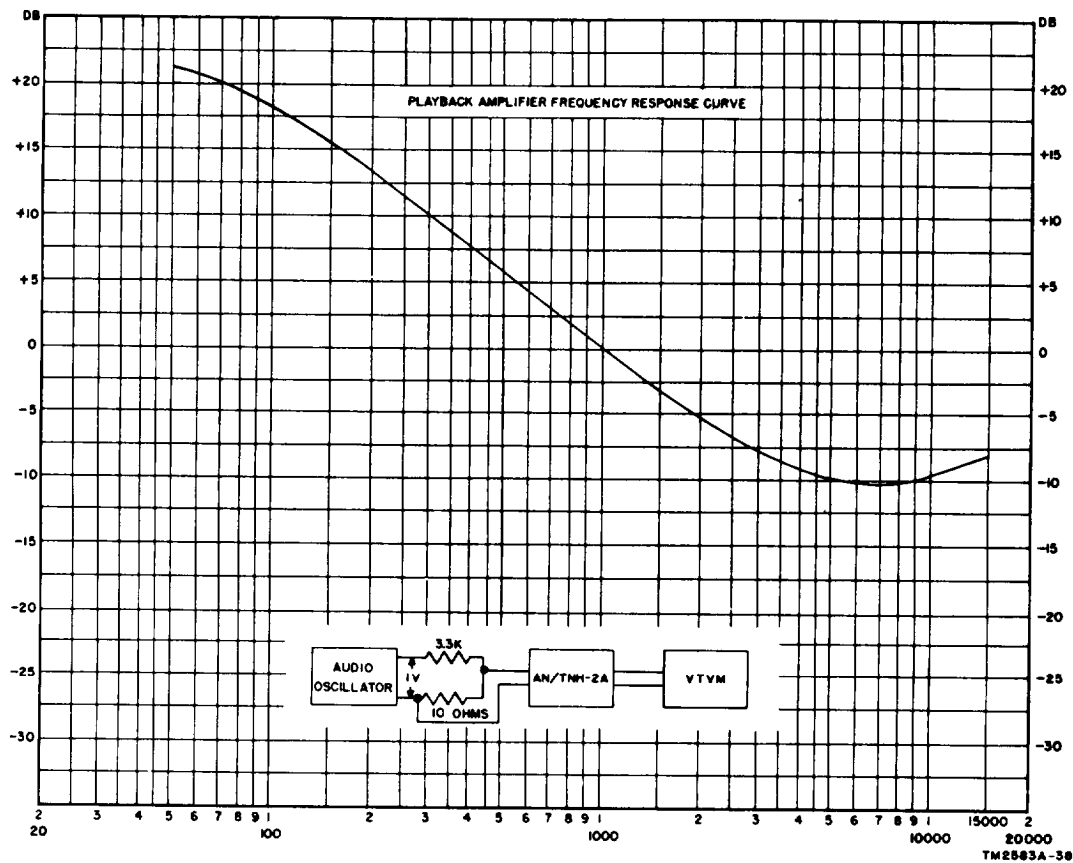

Figure 44. Playback amplifier frequency response curve.

to ground. Connect the vtvm across the 1K resistor.

b. Connect the equipment to a power source, and operate the equipment,

c. Turn the EQUALIZATION switch to the 15 I.P.S. position.

d. Turn the INPUT SELECTOR SWITCH to the BRIDGE position.

e. Connect an audio oscillator to pins 2 and 3 of the INPUT connector. Set the audio oscillator to deliver a .5-volt output at 1 kc.

f. Adjust the RECORD LEVEL control until the needle of the vtvm indicates a .78 volt.

g. Set the audio oscillator to deliver a .5-volt output at 10 kc.

h. Adjust capacitor C107 (fig. 27) until the needle of the vtvm indicates the level shown on the curve of figure 45.

i. Similarly, check the response at 5 kc.

j. Check the frequency response at 7 1/2-ips operation in the same manner indicated for 15 ips (a through i above), except for the following:

- (1) Turn the EQUALIZATION switch to the 7 1/2 I.P.S. position.
- (2) Check the response at 400 cps, 1 kc, 3 kc, 5 kc, and 7 kc,
- (3) Adjust capacitor C108 (fig. 27) instead of C107.

#### 85. Amplifier Gain, Recording Amplifier Circuit of Amplifier

To check the over-all gain of the recording amplifier, proceed as follows:

a. Connect and operate the equipment as indicated in paragraph 83.

b. Turn the EQUALIZATION switch to the 15 I.P.S. position.

c. Turn the INPUT SELECTOR SWITCH to the BRIDGE position.

d. Connect an audio oscillator to pins 2 and 3 of the INPUT connector. Set the audio oscillator for .1-volt output at 1 kc.

e. Turn the RECORD LEVEL control to a setting of 10.

f. The needle of the vtvm should indicate .28 volt  $\pm$ .05 volt.

## 86. Recording Bias Adjustment

To adjust the bias level to the recorder head, proceed as follows:

*a.* Remove the cover of the sound head assembly (fig. 38).

*b.* Demagnetize the heads in the sound head assembly with a standard demagnetizer. Bring the tip of the demagnetizer near the core of the head and run the demagnetizer up and down. Slowly remove the demagnetizer from the head.

*c.* Adjust the controls of the equipment for recording at 15 ips.

*d.* Install and thread the tape.

*e.* Connect an audio oscillator to pins 2 and 3 of the INPUT connector. Set the oscillator to deliver an output of .5 volt at 400 cps.

*f.* Turn the INPUT SELECTOR SWITCH to the BRIDGE position.

*g.* Connect the equipment to a power source, turn on the equipment, and allow 5 minutes for warm up.

*h.* Adjust the RECORD LEVEL control to a setting of 2.

*i.* Turn the METER SELECTOR switch to the PLAYBACK LEVEL position.

*j.* Adjust the PLAYBACK LEVEL control to a setting of 8.

*k.* Press the PLAY and RECORD switches.

1. Turn variable resistor R125 (fig. 27) to the extreme counterclockwise position; then turn the control clockwise until the needle of meter M101 indicates maximum. Continue turning the control clockwise until the needle of the meter indicates 1 vu less than maximum. Note the reading of the meter.

*m.* Turn the METER SELECTOR switch to the BIAS position. Adjust variable resistor R130 (fig. 27) until the needle of the meter indicates 0 vu.

*n.* Repeat the instructions given in *l* and *m* above.

*o.* Turn the METER SELECTOR switch to the RECORD LEVEL position. Adjust variable resistor R115 (fig. 27) to obtain readings identical with those given in 1 above.

## 87. Noise Balance Adjustment

To adjust the noise balance, first adjust the bias as indicated in paragraph 86, then proceed as follows:

*a.* Connect Sound Analyzer TS-615A/U (distortion meter) to the output of the amplifier. Adjust the distortion meter for 800-cps output.

*b.* Connect an audio oscillator to the INPUT connector. Adjust the audio oscillator for 400-cps output.

*c.* Install and thread a tape that has been erased.

*d.* Operate the RECORD LEVEL control until the needle of vu meter M101 indicates 0 vu.

*e.* Operate the PLAYBACK LEVEL control to a setting of 8.

*f.* Press the PLAY and the RECORD switches.

*g.* Slowly turn variable resistor R129 (fig. 27) to the extreme counterclockwise position. Note the setting for minimum second harmonic distortion. Slowly turn variable resistor R129 to the extreme clockwise position. Note the setting for minimum second harmonic distortion. Repeat this procedure until the best setting for minimum second harmonic distortion is found.

*h.* After adjusting the noise balance, recheck the bias level adjustment (par. 86).

*i.* If a distortion meter is not available, noise balance can be obtained using a suitable headset. First adjust the bias (par. 86), then proceed as follows:

(1) Connect the headset to the output of the amplifier.

(2) Operate the equipment as indicated in *c* through *f* above.

(3) Listen to the level of the high frequency noise through the headset. Adjust the setting of variable resistor R129 (fig. 27) until the best setting for minimum noise level is found.

## 88. Erase Current Adjustment

To adjust the level of erase current, proceed as follows :

*a.* Connect and operate the equipment as a recorder (par. 14).

*b.* Turn the METER SELECTOR switch to the ERASE position.

*c.* Depress the PLAY and the RECORD switches.

*d.* Adjust capacitor C115 (fig. 27) until the needle of vu meter M101 indicates 0 vu.

## 89. Reproducer Head Alignment (fig. 38)

Alignment of the reproducer head consists of adjusting the position of the head in azimuth to assure proper frequency response, low noise, high output, and low distortion. Normally, the head will not require alignment, except if the head has been removed, or if the entire sound head assembly is replaced. To align the reproducer head, proceed as follows:

- a. Remove the cover of the sound head assembly.
- b. Demagnetize the head, using a standard demagnetizer. Bring the tip of the demagnetizer near the core of the head and then run the demagnetizer up and down. Slowly remove the demagnetizer from the head.
- c. Connect the equipment for playback operation at 15 ips (par. 10).
- d. Obtain a *standard* tape and thread the tape.
- e. Adjust the PLAYBACK LEVEL control to a setting of 10.
- f. Turn the METER SELECTOR switch to the PLAYBACK LEVEL position.
- g. Turn on the equipment and allow 5 minutes for warm up.
- h. Operate the equipment for playback (par. 18) with a 10-kc signal from the standard tape.
- i. Turn the tension screw that holds the reproducer head until the needle of vu meter M101 indicates a maximum reading.

## 90. Recorder Head Alignment (fig. 38)

To align the recorder head, first align the reproducer head (par. 89), then proceed as follows :

- a. Connect the equipment for recording at 15 ips (par. 10).
- b. Install and thread a blank tape.
- c. Connect an audio oscillator to pins 2 and 3 of the INPUT connector.
- d. Turn the INPUT SELECTOR SWITCH to the BRIDGE position.
- e. Turn on the equipment and allow 5 minutes for warm up.
- f. Adjust the audio oscillator to deliver 1-volt output at 10 kc.
- g. Adjust the RECORD LEVEL control until the needle of meter M101 indicates -5 vu.
- h. Connect a vtm across pins 2 and 3 of the OUTPUT connector.

i. Turn the METER SELECTOR switch to the PLAYBACK LEVEL position.

j. Press the PLAY and the RECORD switches.

k. Adjust the tension screw that holds the recorder head until the needle of the external vtm indicates a maximum reading.

## 91. Recording Amplifier and Playback Amplifier, Frequency Response

The frequency response of the recording amplifier and playback amplifier should be checked for both 15-ips and 7½-ips operation after alignment of the sound head (pars. 89 and 90). First check the 15-ips operation as follows :

- a. Connect the equipment to a power source.
- b. Turn the EQUALIZATION switch to the 15 I.P.S. position.
- c. Move the 7½"-15" switch to the 15" position.
- d. Turn the METER SELECTOR switch to the RECORD LEVEL position.
- e. Turn the INPUT SELECTOR SWITCH to the BRIDGE position and turn the RECORD LEVEL control to a setting of 8.
- f. Connect an audio oscillator to pins 2 and 3 of the INPUT connector. Set the audio oscillator to deliver a .5-volt output at 1 kc.
- g. Turn the equipment on and push the PLAY and the RECORD switches.
- h. Adjust the RECORD LEVEL control until the needle of meter M101 indicates -10 vu.
- i. Turn the METER SELECTOR switch to the PLAYBACK LEVEL position. The needle of meter M101 should indicate -10 vu.
- j. Set the audio oscillator to deliver a .5-volt output at 10 kc.
- k. Adjust capacitor C107 (fig. 27) until the needle of meter M101 indicates -10 vu  $\pm$  2 vu.
  1. Repeat the instruction given in g, h, and i above. If the reading is not -10 vu  $\pm$  2 vu, reset capacitor C107, then repeat the instructions given in j and k above. Record the measurements.
  - m. Set the audio oscillator to deliver a 1-volt output at 50 cps; the reading should be -10 vu  $\pm$  2 vu.
  - n. Check the response at 100, 400, and 500 cps. Record the measurements.

*o.* If the readings are incorrect, recheck the bias adjustment (par. 86), head alignment (par. 89, and 90), tape magnetization (par. 88), and settings of variable resistors R140 and R125 (fig. 27).

*p.* Check the frequency response at 7½-ips operation in the same manner as indicated for 15 ips (*a* through *o* above), except for the following:

- (1) Set the EQUALIZATION switch to the 7½ I.P.S. position.
- (2) Set the 7½"-15" switch to the 7" position.
- (3) Check the equipment at 400 cps, 1 kc, 3 kc, 5 kc, and 7 kc.
- (4) Adjust capacitor C108 instead of capacitor C107.

## 92. Distortion Measurements, Amplifier

Total harmonic distortion of the amplifier should be checked for both 15-ips and 7½-ips operation. First check the 15-ips operation as follows:

- a.* Connect the equipment to a power source.
- b.* Turn the EQUALIZATION switch to the 15 I.P.S. position.
- c.* Move the 7½"-16" switch to the 15" position.
- d.* Turn the INPUT SELECTOR SWITCH to the BRIDGE position.
- e.* Turn the METER SELECTOR switch to the RECORD LEVEL position.
- f.* Set the PLAYBACK LEVEL control to 8, approximately.
- g.* Connect an audio oscillator to the INPUT connector. Set the audio oscillator to deliver a 1-volt output at 400 cps.
- h.* Turn the equipment on and press the PLAY and the RECORD switches.
- i.* Adjust the RECORD LEVEL control until the needle of vu meter M101 indicates 0 vu.
- j.* Connect Sound Analyzer TS-615A/U to the EARPHONES jack.
- k.* If a 600-ohm output of the amplifier is required, move the LINE TERMINATION switch to the ON position.
- l.* Turn the METER SELECTOR switch to the PLAYBACK LEVEL position.
- m.* Adjust the PLAYBACK LEVEL control until meter M101 indicates 0 vu.

*n.* Total harmonic distortion as read on the TS-615A/U should be less than 3 per cent,

*o.* Repeat the instructions given in *g* through *n* above except for the following:

- (1) Operate the EQUALIZATION switch to the 7½ I.P.S. position.
- (2) Move the 7½"-15" switch to 7½ position.

*p.* If total harmonic distortion exceeds 3 per cent, proceed as follows:

- (1) Demagnetize the sound heads.
- (2) Check the bias level adjustment (par. 86).
- (3) Check the noise balance circuit adjustment (par. 87).
- (4) Check the amplifier (par. 82 through 85).

## 93. Flutter and Wow Measurements

Flutter and wow of the recorder-reproducer should be checked for both 15-ips and 7½-ips operation. The procedure for checking flutter and wow is the same for both speeds, except for control settings. Proceed as follows:

- a.* Connect the equipment to a suitable power source.
- b.* Connect the audio amplifier to the amplifier.
- c.* Turn the EQUALIZATION switch to the 15 I.P.S. position.
- d.* Move the 7½"-15" switch to the 15" position.
- e.* Turn the INPUT SELECTOR SWITCH to the BRIDGE position.
- f.* Turn the METER SELECTOR switch to the RECORD LEVEL position.
- g.* Set the PLAYBACK LEVEL control to 8, approximately.
- h.* Connect an audio oscillator to the INPUT connector; set the audio oscillator to deliver a 1-volt output at 3,000 cps.
- i.* Turn the equipment on and press the PLAY and the RECORD switches.
- j.* Adjust the RECORD LEVEL control until the needle of meter M101 indicates 0 vu.
- k.* Connect Flutter Indicator PH-593/PFQ to the PHONES jack and turn on the PH-593/PFQ. Operate the PH-593/PFQ in accordance with instructions furnished with the equipment.
- l.* Turn the METER SELECTOR switch to the PLAYBACK LEVEL position.

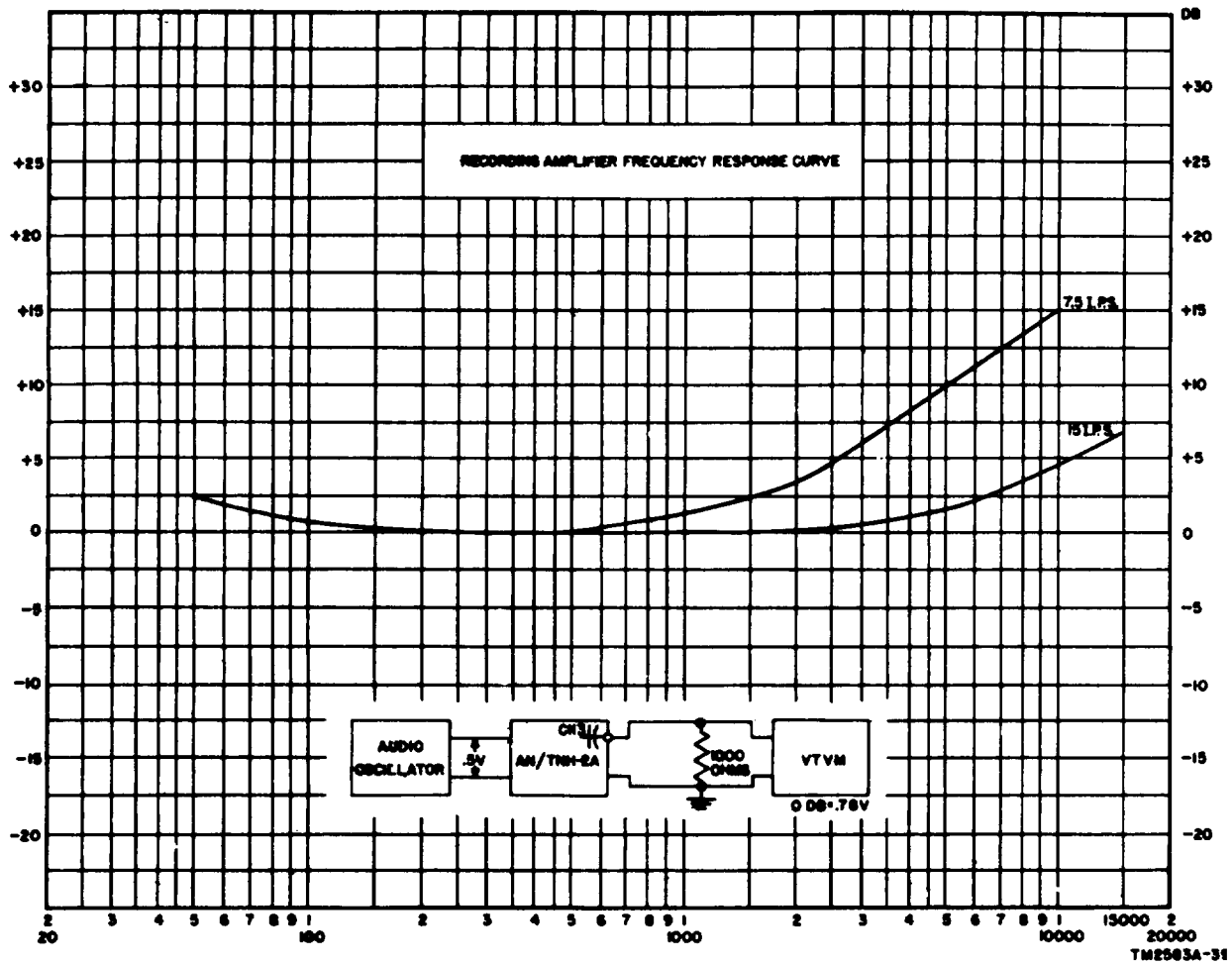

Figure 45. Recording amplifier, frequency response curve.



*m.* Adjust the PLAYBACK LEVEL control until meter M101 indicates 0 vu.

*n.* Total flutter and wow should be less than .2 per cent.

*o.* Make measurement for 7½-ips operation with the EQUALIZATION SWITCH set to the 7½" position. Total flutter and wow should be less than .25 per cent.

#### 94. Signal-to-noise Ratio

To measure the signal-to-noise ratio, proceed as follows:

*a.* Connect the equipment to a suitable power source.

*b.* Turn the INPUT SELECTOR SWITCH to the BRIDGE position.

*c.* Turn the EQUALIZATION switch to the 7½ I.P.S. position.

*d.* Move the 7½-15" switch to 7 ½" position.

*e.* Connect a vvm and a distortion meter across the OUTPUT connector.

*f.* Turn the METER SELECTOR switch to the PLAYBACK LEVEL position.

*g.* Connect an audio oscillator to pins 2 and 3 of the INPUT connector. Adjust the audio oscillator to deliver a 5-volt output at 400 cps.

Place a tape on the recorder-reproducer and thread the tape.

*h.* Move the ON-OFF switch to the ON position.

*i.* Press the PLAY and the RECORD switches.

*j.* Turn the RECORD LEVEL control until the distortion meter indicates 3 per cent third harmonic distortion. Simultaneously, turn the PLAYBACK LEVEL control until meter M101 indicates 0 vu. Adjust both controls until both conditions are obtained.

*k.* Record for 2 minutes.

*l.* Press the STOP switch,

*m.* Press the REWIND switch to allow playback of the recorded signal (*k* above), then press the STOP switch.

*n.* Press the PLAY switch.

*o.* Turn the PLAYBACK LEVEL control to maintain a reading of 0 vu on meter M101. Record the output indicated on the vvm.

*p.* When the signal disappears (extremely low reading on vvm), record the reading of the vvm.

*q.* The signal-to-noise ratio is determined by ratio of the values in *o* and *p* above. Ratio should be 50 db minimum.

## RESISTOR COLOR CODE MARKING (MIL-STD RESISTORS)

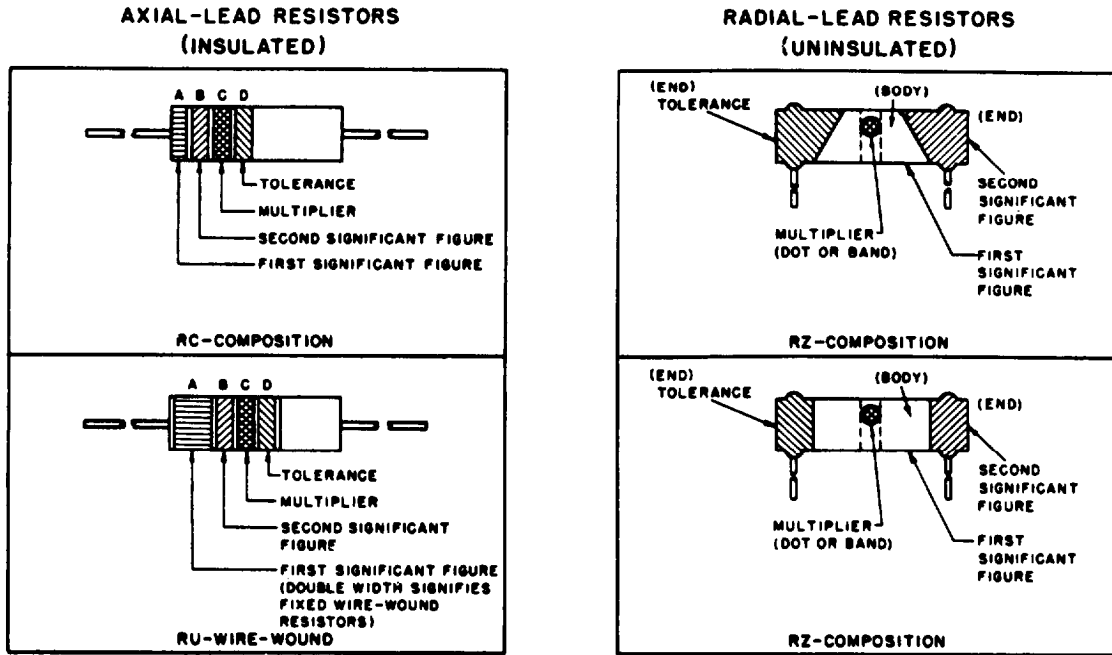

### RESISTOR COLOR CODE

BAND A OR BODY*		BAND B OR END*		BAND C OR DOT OR BAND*		BAND D OR END*	
COLOR	FIRST SIGNIFICANT FIGURE	COLOR	SECOND SIGNIFICANT FIGURE	COLOR	MULTIPLIER	COLOR	RESISTANCE TOLERANCE (PERCENT)
BLACK	0	BLACK	0	BLACK	1	BODY	$\pm 20$
BROWN	1	BROWN	1	BROWN	10	SILVER	$\pm 10$
RED	2	RED	2	RED	100	GOLD	$\pm 5$
ORANGE	3	ORANGE	3	ORANGE	1,000		
YELLOW	4	YELLOW	4	YELLOW	10,000		
GREEN	5	GREEN	5	GREEN	100,000		
BLUE	6	BLUE	6	BLUE	1,000,000		
PURPLE (VIOLET)	7	PURPLE (VIOLET)	7				
GRAY	8	GRAY	8	GOLD	0.1		
WHITE	9	WHITE	9	SILVER	0.01		

\* FOR WIRE-WOUND-TYPE RESISTORS, BAND A SHALL BE DOUBLE-WIDTH. WHEN BODY COLOR IS THE SAME AS THE DOT (OR BAND) OR END COLOR, THE COLORS ARE DIFFERENTIATED BY SHADE, GLOSS, OR OTHER MEANS.

**EXAMPLES (BAND MARKING):**  
 10 OHMS  $\pm 20$  PERCENT: BROWN BAND A; BLACK BAND B; BLACK BAND C; NO BAND D.  
 4.7 OHMS  $\pm 5$  PERCENT: YELLOW BAND A; PURPLE BAND B; GOLD BAND C; GOLD BAND D.

**EXAMPLES (BODY MARKING):**  
 10 OHMS  $\pm 20$  PERCENT: BROWN BODY; BLACK END; BLACK DOT OR BAND; BODY COLOR ON TOLERANCE END.  
 3,000 OHMS  $\pm 10$  PERCENT: ORANGE BODY; BLACK END; RED DOT OR BAND; SILVER END.

STD-R1

*Figure 46. MIL-STD resistor color codes.*

**CAPACITOR COLOR CODE MARKING  
(MIL-STD CAPACITORS)**

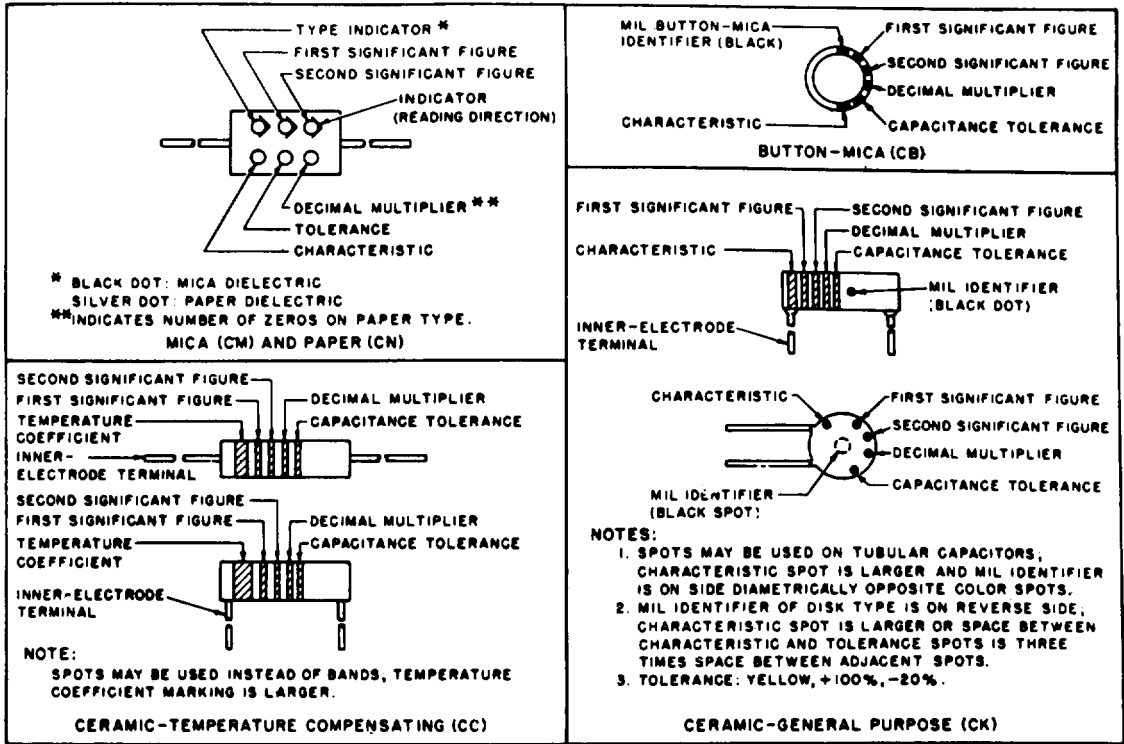

**CAPACITOR COLOR CODE**

COLOR	SIG FIG.	MULTIPLIER		CHARACTERISTIC				TOLERANCE 2				TEMPERATURE COEFFICIENT (UUF/UF/°C)	
		DECIMAL	NUMBER OF ZEROS	CM	CN	CB	CK	CM	CN	CB	CC		
											OVER 10UUF		10UUF OR LESS
BLACK	0	1	NONE		A			20	20	20	20	2	ZERO
BROWN	1	10	1	B	E	B	W					1	-30
RED	2	100	2	C	H		X	2		2	2		-60
ORANGE	3	1,000	3	D	J	D			30				-150
YELLOW	4	10,000	4	E	P								-220
GREEN	5		5	F	R						5	0.5	-330
BLUE	6		6		S								-470
PURPLE (VIOLET)	7		7		T	W							-750
GRAY	8		8				X					0.25	+30
WHITE	9		9								10	1	-330 (± 500) 3
GOLD		0.1						8		5			+100
SILVER		0.01						10	10	10			

1. LETTERS ARE IN TYPE DESIGNATIONS GIVEN IN MIL-C SPECIFICATIONS.  
 2. IN PERCENT, EXCEPT IN UUF FOR CC-TYPE CAPACITORS OF 10 UUF OR LESS.  
 3. INTENDED FOR USE IN CIRCUITS NOT REQUIRING COMPENSATION.

STD-C1

Figure 47. MIL-STD capacitor color codes.

## CHAPTER 7

### SHIPMENT AND LIMITED STORAGE AND DEMOLITION TO PREVENT ENEMY USE

#### 95. Removing Equipment from Service

- a. Disconnect the power cable from the power source.
- b. Disconnect the microphone and the headset (and external speaker, if used).
- c. Disconnect the interconnecting power cable and output cable.

#### 96. Materials Required for Repacking

a. The following chart lists the materials required for repacking the recorder-reproducer set after the equipment has been removed from service.

Material	Quantity
Waterproof barrier material	50 sq ft
Corrugated fiberboard, single-faced, flexible	55 sq ft
Gummed tape	40 ft
Pressure-sensitive tape	36 ft
Strapping steel, flat	33 ft
Wooden shipping box	2 ea.

b. Fabricate the two wooden shipping boxes to the size indicated in the chart below.

Box	Dimensions				
	Height (in.)	Width (in.)	Depth (in.)	Vol. (cu ft)	Board feet
1. Recorder-reproducer carrying case.	23	27	27	9.4	27 3/8
2. Audio amplifier carrying case.	20	31	27	10	28

#### 97. Repacking

a. Package each technical manual within a close-fitting bag fabricated of waterproof barrier material. Seal the seams with water resistant, pressure-sensitive tape.

b. Package each spare tube in flexible single-faced, corrugated fiberboard and secure the wrap with gummed paper tape. Consolidate the packaged tubes within a wrap of flexible single-faced corrugated fiberboard, and secure the consolidated wrap with gummed paper tape.

c. Place each reel in a metal container and seal the container with pressure-sensitive tape; package each spare part and each accessory item in the same manner indicated in *b* above.

d. Stow all items within the compartments of the audio amplifier carrying case. Close the case cover and secure the fastenings.

e. Close the covers of the recorder-reproducer carrying case and secure the fastenings.

f. Cushion each carrying case on all surfaces with pads fabricated of flexible, single-faced, corrugated fiberboard. Secure the cushioning with gummed paper tape.

g. Place a suitable waterproof case liner within each wooden case.

h. Place each cushioned carrying case within the suitable wooden case. Seal the case liner with waterproof tape.

i. Close and nail the wooden case.

j. For intertheater shipments, use steel strapping to secure the sides, top, and bottom of the cases.

k. Mark cases in accordance with the requirements of SR-55-720-1, Section II.

## 98. Methods of Destruction

*Note.* The demolition procedures outlined in *a* through *g* below will be used to prevent the enemy from using or salvaging this equipment. Demolition of the equipment will be accomplished only upon order of the commander.

*a. Smash.* Smash the controls, tubes, capacitors, transformers, switches, microphone, loudspeakers, headsets, meters, and motors; use sledges, axes, handaxes, pickaxes, hammers, crowbars, or other heavy tools.

*b. Cut.* Cut the power cables, the headset

cord, the microphone cord, and all interconnecting cables; use axes, handaxes, or machetes.

*c. Burn.* Burn all cords, carrying cases, and technical manuals; use gasoline, kerosene, oil, flame throwers, or incendiary grenades.

*d. Bend.* Bend all panels.

*e. Explosives.* Use firearms, grenades, or TNT.

*f. Disposal.* Bury or scatter the destroyed parts in slit trenches, fox holes, or throw them into streams.



# INDEX

	Paragraph	Page		Paragraph	Page
<b>A</b>					
Adjustments:			Description . . . . .	6e	3
Bias level . . . . .	86	75	Dimension . . . . .	5	2
Brake belt tension . . . . .	77	70	Case, recorder-reproducer:		
Erase current . . . . .	88	75	Description . . . . .	6b	3
Noise balance circuit . . . . .	87	75	Dimensions . . . . .	5	2
Pressure roller . . . . .	78	70	Characteristics, technical . . . . .	4	2
Solenoid limiting am. . . . .	76	70	Chart, trouble-shooting . . . . .	65	57
Solenoid throw . . . . .	76	70	Checks, amplifier:		
Take-up reel tension . . . . .	77	70	Electrical . . . . .	82, 83, 84, 85	73, 74
Alignment:			Operational . . . . .	43	33
General . . . . .	79	71	Shorts . . . . .	63	51
Recorder head . . . . .	90	76	Checks, audio amplifier:		
Reproducer head . . . . .	89	76	Electrical . . . . .	80	73
Teat equipment required . . . . .	61	49	Operational . . . . .	43	33
Amplifier:			Shorts . . . . .	64	51
Checking . . . . .	63	51	Circuit analysis:		
Circuit analysis:			Amplifier . . . . .	53	42
Recording . . . . .	53	42	Audio amplifier . . . . .	57	47
Reproducing . . . . .	54	45	Erase-oscillator . . . . .	53	42
Connectors . . . . .	29 a	24	Input . . . . .	52	41
Controls . . . . .	28 a	23	Meter . . . . .	55	46
Description . . . . .	6c	3	Playback . . . . .	54	45
Final test . . . . .	91	76	Power supplies . . . . .	56	46
Amplifier, audio:			Recording . . . . .	53	42
Checking . . . . .	64	51	Rewind . . . . .	50	41
Circuit analysis . . . . .	57	47	Wind . . . . .	51	41
Connectors . . . . .	29b	24	Common names . . . . .	7	6
Controls . . . . .	28b	23	Complement, electron tubes . . . . .	4	2
Description . . . . .	6f	3	Components table . . . . .	5	2
Final teat . . . . .	80, 81	73	Connections:		
Arctic operation . . . . .	25	21	Program line . . . . .	11 b	11
<b>B</b>			Telephone . . . . .	11 a	9
Bias adjustment . . . . .	86	75	connectors and jacks:		
Block diagrams:			Amplifier . . . . .	29a	24
Playback . . . . .	46	38	Audio amplifier . . . . .	29b	24
Audio amplifier . . . . .	57	47	Controls and their uses . . . . .	28	23
Recording . . . . .	45	38	Crates, dimenaions and weights . . . . .	8	7
Brakes:			<b>D</b>		
Adjustment . . . . .	77	70	Data:		
Operation . . . . .	49	40	Electron tube . . . . .	4	2
<b>C</b>			General, maintenance . . . . .	60	49
Capstan motor:			Packaging . . . . .	8	7
Lubrication . . . . .	35	29	shipping . . . . .	97	82
Operation . . . . .	49	40	Technical . . . . .	4	2
Replacement . . . . .	73	66	Definition, preventive maintenance . . . . .	32	25
Cables . . . . .	6	3	Demagnetizer, head . . . . .	86	75
Case, amplifier:			Demolition . . . . .	98	83
			Description, general . . . . .	6	3
			Desert operation . . . . .	26	21

	Paragraph	Page
Dimensions . . . . .	5	2
Disassembly:		
General . . . . .	95	82
Recorder-reproducer . . . . .	71	66
E		
Electrical:		
Characteristics . . . . .	4	2
Performance . . . . .	43	33
Electron tube complement . . . . .	4	2
Equalizing amplifier V102A . . . . .	53 c	42
Equalization circuit . . . . .	53 d	43
Equipment:		
Characteristics, technical . . . . .	4	2
Description . . . . .	6	3
Installation . . . . .	10	7
Performance check list . . . . .	43	33
Use . . . . .	3	1
Erase current adjustment . . . . .	88	75
Erase-oscillator V107 . . . . .	53 h	43
F		
Fast forward operation . . . . .	20	19
Fast rewind operation . . . . .	19	19
Feedback:		
Amplifier . . . . .	54 d	46
Audio amplifier . . . . .	57 b	47
Final teat procedures . . . . .	79	71
Flutter and wow:		
General . . . . .	4	2
Measurements . . . . .	93	77
Forms and records . . . . .	2	1
Frequency:		
Audio frequency range . . . . .	4	2
Oscillator . . . . .	53 h	43
Playback . . . . .	82	73
Record . . . . .	84	73
Record playback . . . . .	91	76
I		
Input Connections:		
Microphone . . . . .	10	7
Program line . . . . .	11	9
Telephone line . . . . .	11	9
Inspection, vised . . . . .	39	31
Installation . . . . .	10	7
L		
Lamps, pilot . . . . .	56, 58	46, 47
Localization, trouble . . . . .	59 b	48
Loudspeakers . . . . .	57	47
Lubrication . . . . .	35	29
M		
Maintenance:		
Arctic . . . . .	36c	29
Check schedules . . . . .	34	2 5
Desert . . . . .	36 d	29
Tools . . . . .	30,31	2 4
Tropical . . . . .	36 b	29
Measurements, voltage and resistance:		
Amplifier . . . . .	63	51

	Paragraph	Page
Audio amplifier . . . . .	64	51
Microphone:		
Description . . . . .	6g	3
Input circuit . . . . .	52	41
Recording . . . . .	14	13
Monitoring:		
Playback . . . . .	18	17
Recording . . . . .	17	15
Motor:		
Capstan:		
Operation . . . . .	49	40
Replacement . . . . .	73	66
Supply:		
Operation . . . . .	49	40
Replacement . . . . .	72	66
Take-up:		
Operation . . . . .	49	40
Replacement . . . . .	72	66
Mounting, rack . . . . .	10 c	7
N		
Balance adjustments . . . . .	87	75
Balance circuit . . . . .	53 i	45
Ratio, signal-to-noise . . . . .	94	79
O		
Oscillator, erase . . . . .	53 h	43
Operation:		
Arctic . . . . .	25	21
Desert . . . . .	26	21
Fast forward wind . . . . .	20	19
Monitoring . . . . .	17	15
Playback . . . . .	18	17
Program line . . . . .	16	15
Public address . . . . .	21	19
Recording . . . . .	14	13
Rewinding . . . . .	19	19
Starting . . . . .	13	13
Stopping . . . . .	23	19
Telephone line . . . . .	15	17
Tropical . . . . .	27	21
Winding . . . . .	20	19
output :		
External loudspeaker . . . . .	18 e	17
Headset . . . . .	13 d	17
Internal loudspeaker . . . . .	18 d	17
P		
Painting . . . . .	37	29
Packaging data . . . . .	8	7
Parts, replacement . . . . .	70	66
Performance checks . . . . .	42	32
Performance check list . . . . .	43	33
Physical characteristics, general . . . . .	6	3
Playback amplifier:		
Circuit . . . . .	54	45
Equalization . . . . .	54C	45
Frequency response . . . . .	82	73
Output amplifier V106 . . . . .	54e	46
Preamplifier V104 . . . . .	5 4 b	45



	Paragraph	Page		
Playback operation . . . . .	18	17	S	
Playing time . . . . .	4	2	Scope . . . . .	1 1
Preventive maintenance:			Sectionalizing trouble . . . . .	59 b 48
Daily . . . . .	34a	25	Services, used or reconditioned equip-	
Definition . . . . .	32	25	merit . . . . .	12 11
Forms . . . . .	33	25	Shipping data . . . . .	97 82
Monthly . . . . .	34c	29	Signal substitution:	
Services . . . . .	34	25	Amplifier . . . . .	69 63
Weekly . . . . .	34 b	25	Audio amplifier . . . . .	68 63
Program line, connection to . . . . .	11	9	Notes . . . . .	67 63
Program line recording . . . . .	16	15	Signal-to-noise ratio . . . . .	94 79
Public address:			Splicing tape . . . . .	22 19
Circuit . . . . .	47	38	Starting equipment . . . . .	13 13
Connections . . . . .	21	19	Stopping . . . . .	23 19
Operation . . . . .	21	19	Symptoms, trouble . . . . .	65 57
Purpose of equipment . . . . .	3	1		
	R		T	
Recording amplifier V103 . . . . .	53 f	43	Table of components . . . . .	5 2,3
Recording:			Take-up brake assembly . . . . .	77 70
Bias . . . . .	53 h	43	Tape:	
Block diagram . . . . .	45	38	Size . . . . .	4 2
Microphone . . . . .	14	13	Threading . . . . .	13 13
Program line . . . . .	16	15	Technical characteristics . . . . .	4 2
Rate . . . . .	4	2	Telephone line, connection to . . . . .	11 9
Time . . . . .	4	2	Test equipment . . . . .	6 1 49
Record relay . . . . .	53g	43	Tests, final . . . . .	79 71
Records, forms and . . . . .	2	1	Theory of operation:	
Recorder-reproducer:			Amplifier:	
Description . . . . .	6 d, 48	40	Playback . . . . .	46 38
Theory of operation . . . . .	49, 50, 51	40,41	Recording . . . . .	45 38
Rectifier:			Audio amplifier . . . . .	57 47
Amplifier . . . . .	58 b	46	Recorder-reproducer . . . . .	48 40
Audio amplifier . . . . .	58 b	47	Time, recording . . . . .	4 2
Filament . . . . .	56 d	46	Tools, organizational and maintenance	31 24,25
Recorder-reproducer . . . . .	49 f	40	Transformers, dc resistance . . . . .	66 63
Reels . . . . .	4	2	Tropical operation . . . . .	2 7 21
Refinishing . . . . .	37	29	Trouble shooting:	
Removing from service . . . . .	95	82	Chart . . . . .	65 57-62
Repackaging and repacking . . . . .	97	82	Data . . . . .	60 49
Repacking, materials for . . . . .	96	82	Equipment performance check list . .	43 33-35
Replacement:			Organizational . . . . .	31 24,25
Fuse . . . . .	41	32	Precaution . . . . .	62 49
Motors:			Procedures . . . . .	59 48
Capstan . . . . .	73	66	Test equipment . . . . .	61 49
supply . . . . .	72	66		
Take-up . . . . .	72	66	U	
Parts . . . . .	70	66	Uncrating and unpacking . . . . .	9 7
Soundhead assembly . . . . .	74	70	Unusual operation . . . . .	24 21
Tubes, electron . . . . .	40	31	Use of maintenance forma . . . . .	33 25
Reproducer head alignment . . . . .	89	76		
Reproducing . . . . .	18	17	V	
Resistance checks . . . . .	63, 64	51	Visual inspection . . . . .	39 31
Resistances of transformers and coils .	66	63	Voltage amplifier V102B . . . . .	536 43
Rewind:			Voltage and resistance measurements:	
Circuit . . . . .	50	41	Amplifier . . . . .	63 51
Operation . . . . .	19	19	Audio amplifier . . . . .	64 51
Rate . . . . .	19 c	19		
Running spares . . . . .	5	2, 3	W	
Rustproofing and painting . . . . .	37	29	Weatherproofing . . . . .	36 29
			Weights, shipping . . . . .	8 7
			Winding . . . . .	20 19

DEPARTMENT OF THE ARMY  
WASHINGTON 25, D. C., 30 January 1956

TM31-2583A is published for the use of all concerned.

By Order of *Wilber M. Brucker*, Secretary of the Army:

MAXWELL D. TAYLOR,  
*General, United States Army,*  
*Chief of Staff.*

Official:

JOHN A. KLEIN  
*Major General, United States Army,*  
*The Adjutant General.*

DISTRIBUTION:

Active Army:

CNGB (1)  
Tec Svc, DA (1) except  
CSIGO (30)  
Tec Svc Bd (1)  
Hq CONARC (5)  
CONARC Bd (Incl en  
Army AA Comd (2)  
OS Maj Cored (5)  
OS Base Cored (5)  
Log Cored (5)  
MDW(1)  
Armies (5)  
Corps (2)  
Tng Div (2)  
Ft & Cp (2)  
Gen & Br Svc Sch (5) except  
Cig Sch (25)  
Gen Depots (2) except  
Atlanta Gen Depot (None)  
*Sig See*, Gen Depots (10)  
Sig Depots (20)  
Trans Terminal Cored (2)  
OS Sup Agenci-(2)  
Sig Fld Maint Shops (S)

Sig Lab (5)  
Mil Dist (1)

Units organized under following TOE:

7R, Inf Div (2)  
11-7R, Sig Co, Inf Div (2)  
11-16R, Hq&Hq Co, Sig Bn, Corps or Abn  
Corps (2)  
11-57R, Armd Sig Co (2)  
11-127R, Sig Rep Co (2)  
11-128R, Sig Depot Co (2)  
11-500R (AA-AE), Sig Svc Org (2)  
11-557C, Abn Sig Co (2)  
11-587R, Sig Base Maint Co (2)  
11-592R Hq&Hq Co, Sig Base Depot (2)  
11-597R, Sig Base Depot Co (2)  
12-35R, Sp Band (2)  
12-107C, Org or Sep Band (2)  
17R, Armd Div (2)  
32-51R, Hq&Hq Co, Comm Recon GP (2)  
32-55R, CommRecon Bn (2)  
32-56R, Hq&Hq Co, Comm Recon Bn (2)  
32-57R, Comm Recon Opr Co (2)  
32-500R (AA-AG), Comm Recon Org (2)  
33-77R, Loudspeaker and Leaflet Co, Army (2)

NC: State AG (6) ; Units— Same as Active Army except allowance is one copy to each unit.

USAR: None.

For explanation of abbreviations used, see SR 320-50-1.

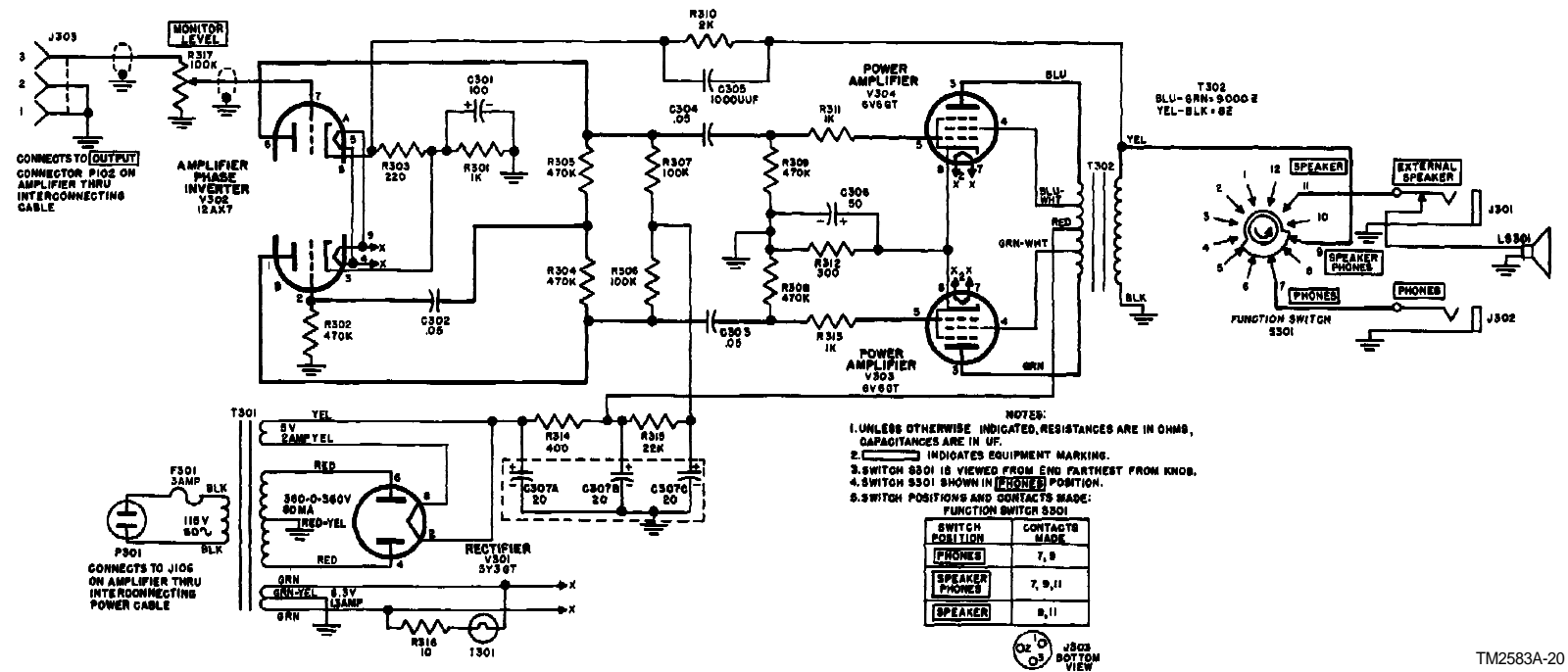

Figure 48. Audio amplifier, schematic diagram.

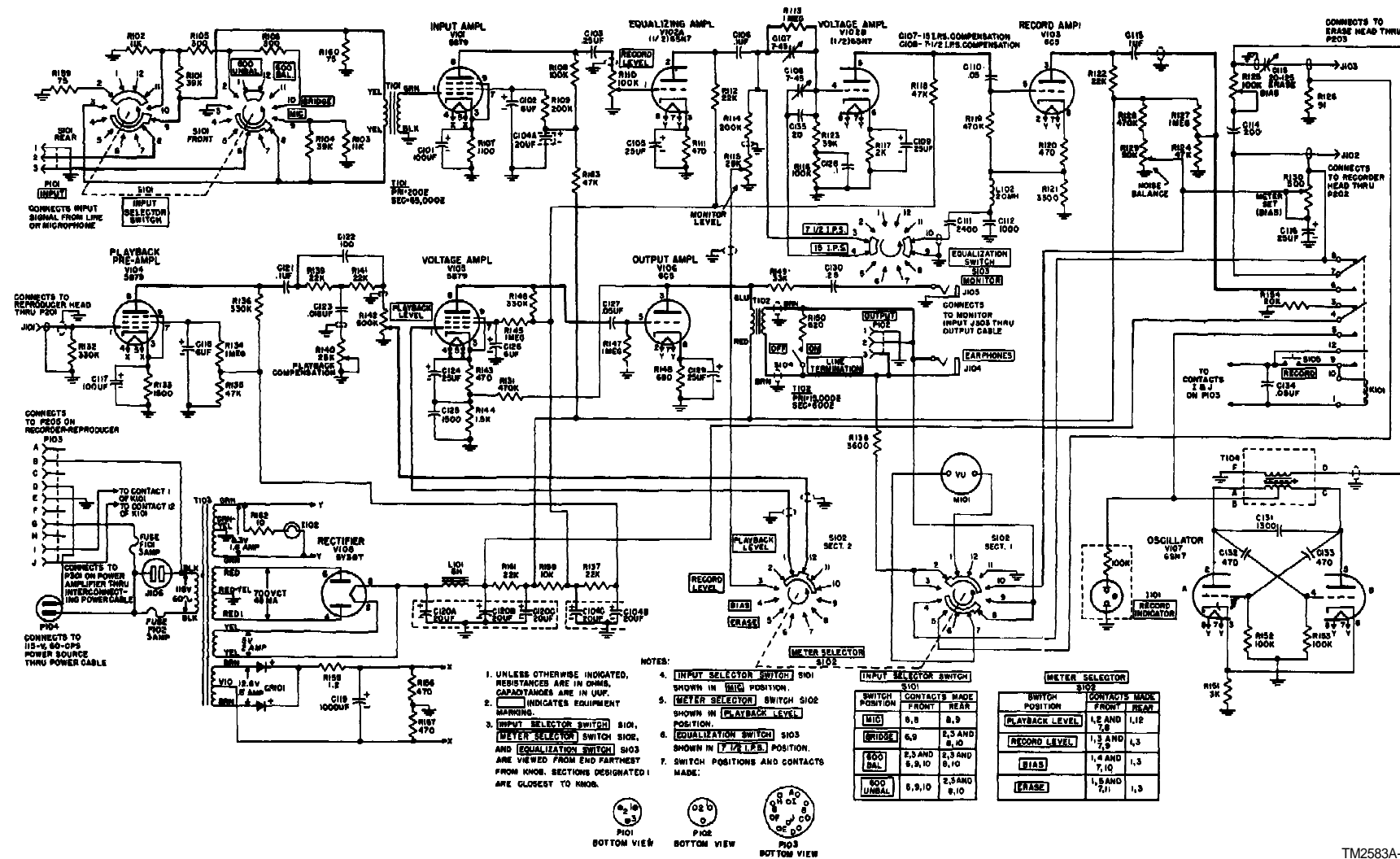

Figure 49. Amplifier, schematic diagram.

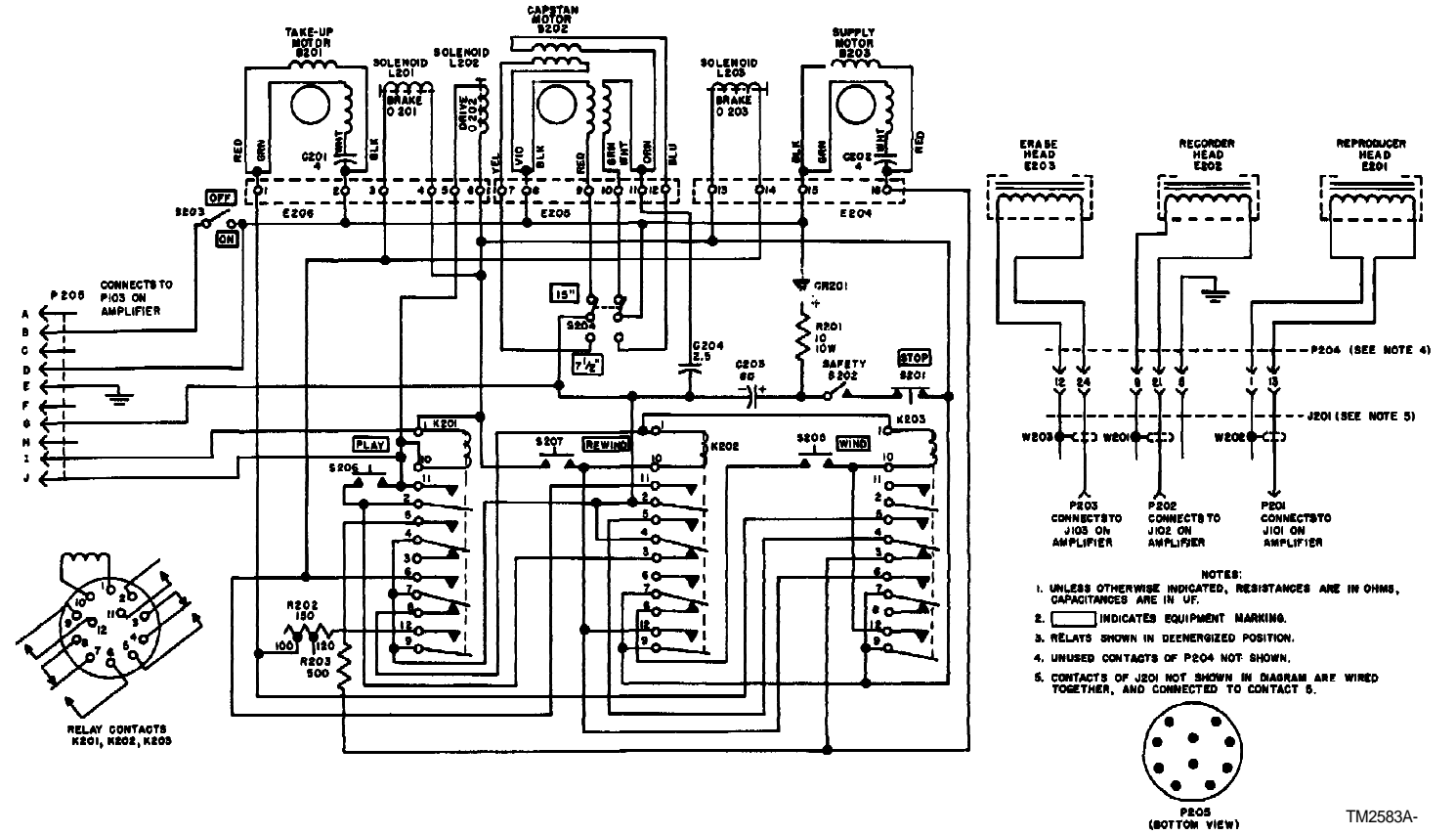

Figure 50. Recorder-reproducer, schematic diagram.

- NOTES:
1. THE SMALL NUMBER ON EACH WIRE (ADJACENT TO THE COMMON OR BASE LINE) CORRESPONDS TO THE LARGE NUMBER ADJACENT TO THE STATION TO WHICH THE WIRE RUNS.
  2. BB INDICATES 20 GAUGE TINNED, ANNEALED COPPER WIRE.
  3. BS1 DENOTES 22 GAUGE TINNED, ANNEALED COPPER WIRE INSULATED WITH SILICON IMPREGNATED FIBER-GLASS SLEEVING.
  4. PT DENOTES PISTAL LEAD.
  5. U DENOTES SHIELDED 22 GAUGE WIRE WITH EXTRUDED VINYL JACKET.
  6. (---) DENOTES SHIELDED CONNECTION.

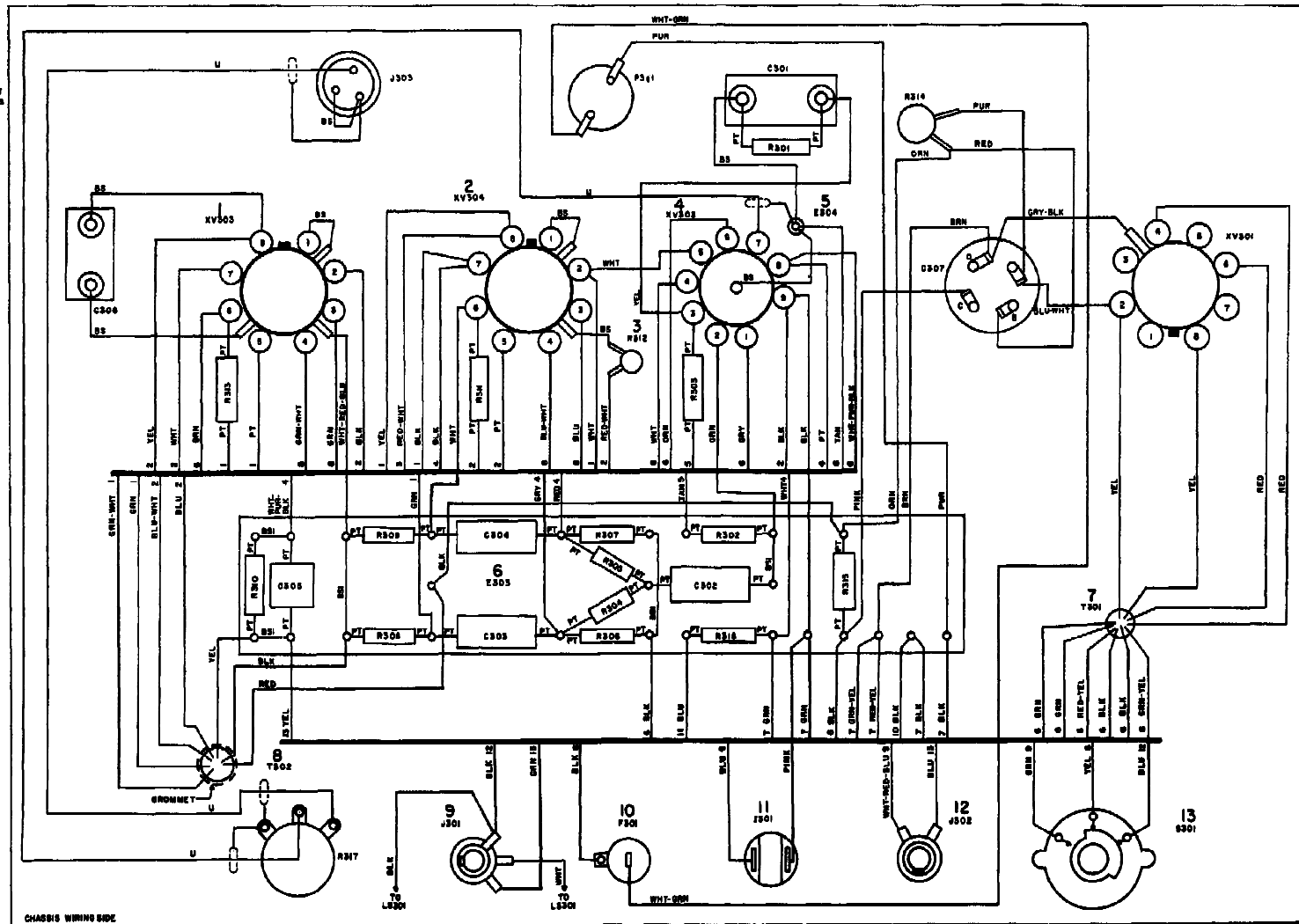
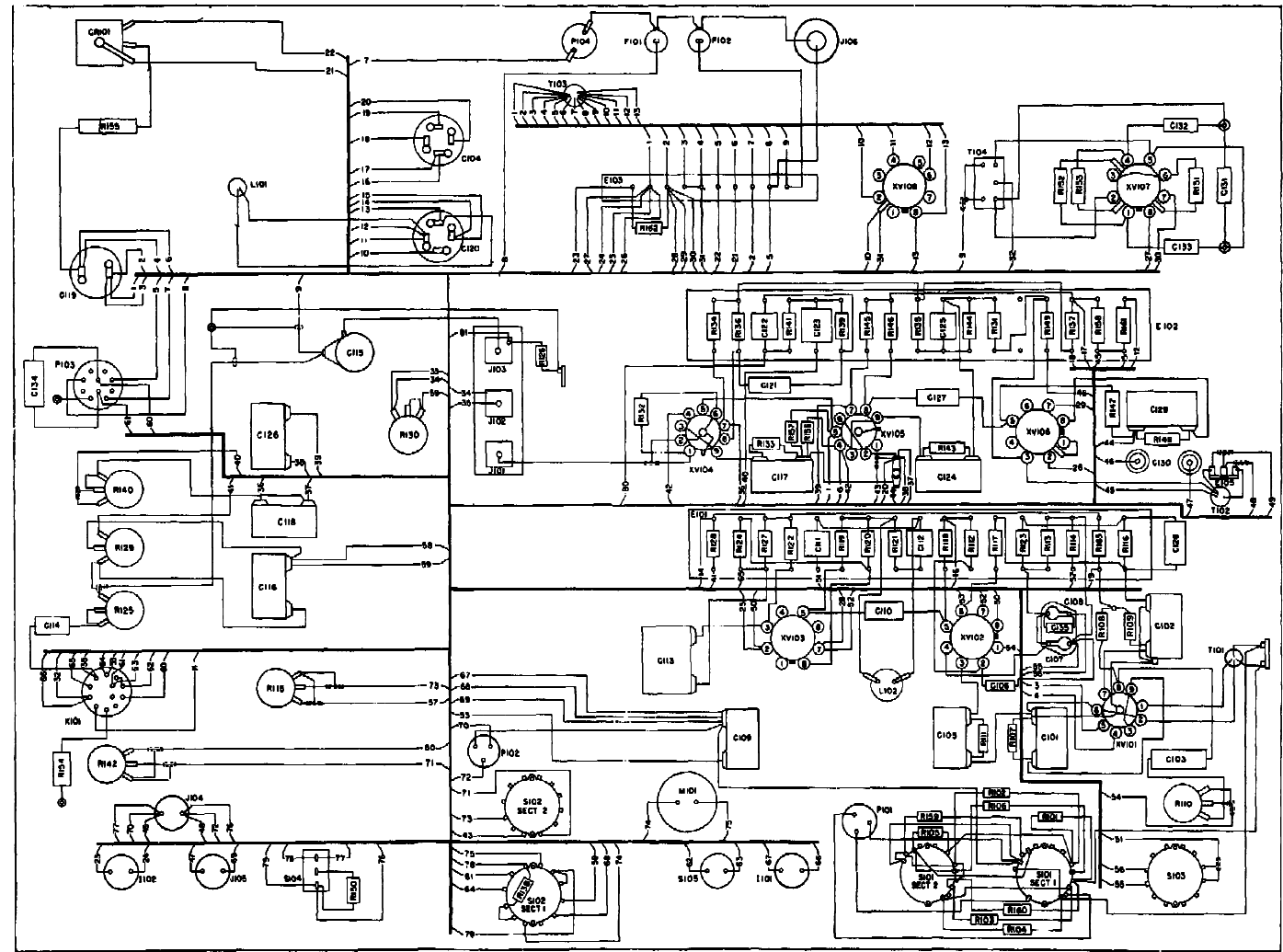
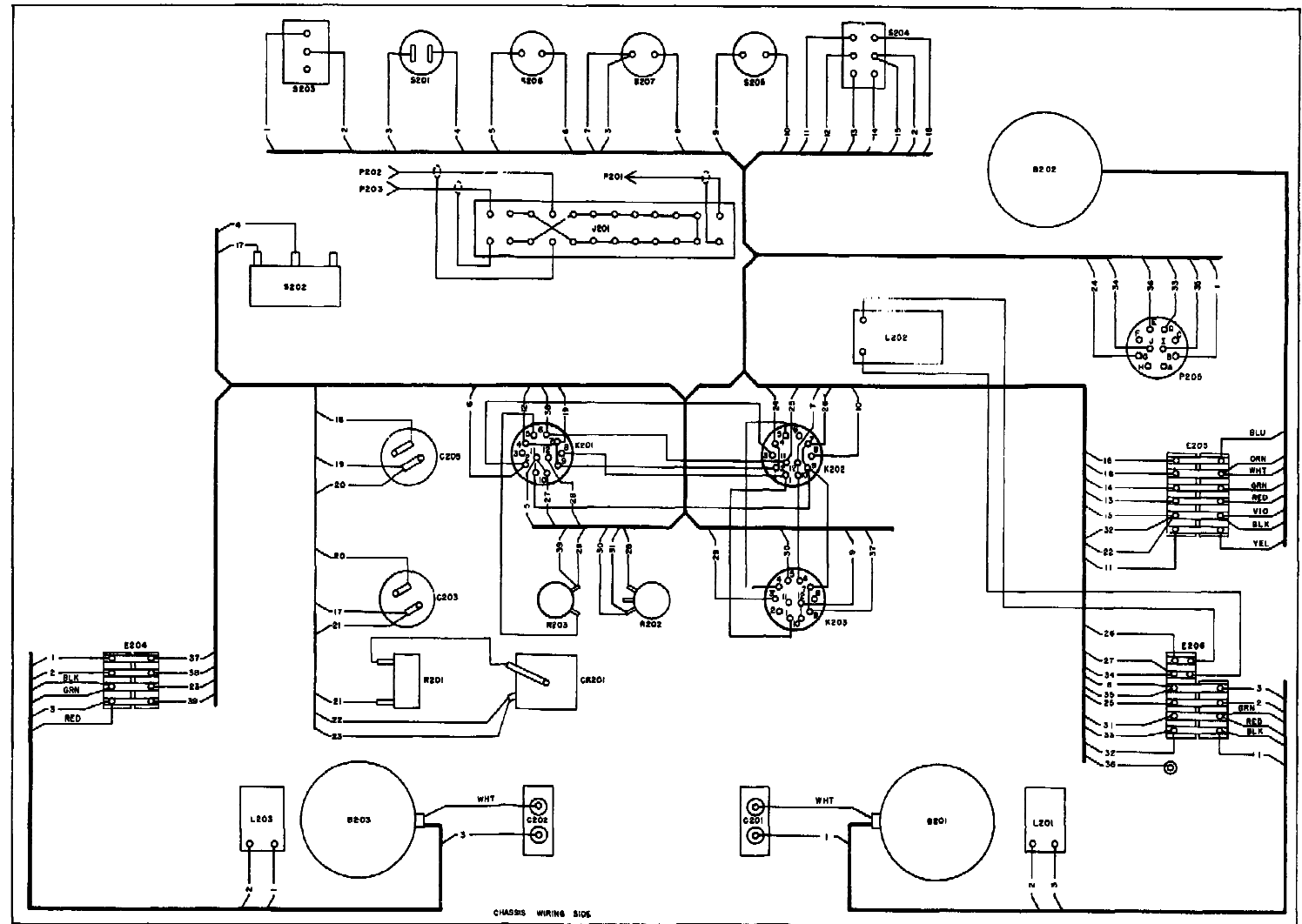

Figure 51. Audio amplifier, wiring diagram.



- NOTES:
1. THE WIRES OF EACH CABLE ARE NUMBERED CONSECUTIVELY. EACH GROUP OF NUMBERS STARTS WITH NO. 1.
  2. IN ANY ONE CABLE, THE TWO POINTS INDICATED BY WIRE NO. 1 ARE CONNECTED TOGETHER TO WIRE NO. 2 AND CONNECTED, ETC.
  3. THE ANGLE AT WHICH A SPECIFIC WIRE ENTERS A CABLE INDICATES THE DIRECTION TO FOLLOW IN FINDING THE OTHER END.

Figure 52. Amplifier, wiring diagram.



NOTES:  
 1. THE WIRES OF EACH CABLE ARE NUMBERED CONSECUTIVELY. EACH GROUP OF NUMBERS STARTS WITH NO. 1.  
 2. IN ANY ONE CABLE, THE TWO POINTS INDICATED BY WIRE NO. 1 ARE CONNECTED; THOSE TIED TO WIRE 2 ARE CONNECTED, ETC.  
 3. THE ANGLE AT WHICH A SPECIFIC WIRE ENTERS A CABLE INDICATES THE DIRECTION TO FOLLOW IN FINDING THE OTHER END.

CHASSIS WIRING SIDE

Figure 53. Recorder-reproducer, wiring diagram.





